



Level



Pressure



Flow



Temperature



Liquid
Analysis



Registration



Systems
Components



Services



Solutions

Technical Information

Alignment Unit FAU40

Mounting accessory for ultrasonic sensors
with separate drive electronics



Application

- Mounting a separate sensor without drive electronics on a silo or tank
- Positioning a separate sensor, e.g. exactly perpendicular to the surface of the liquid or at an angle to the output of a bulk solids silo
- Approved for use in combustible dusts ATEX zone 20

Features and Benefits

- Simple to mount even with slanting mounting pipes
- Ideal reflection with simple orientation
- Maximum use of vessel space
- No interference reflections, e.g. inside the mounting pipe
- Reduction of interference echoes, e.g. from fittings within the silo

Application

Example

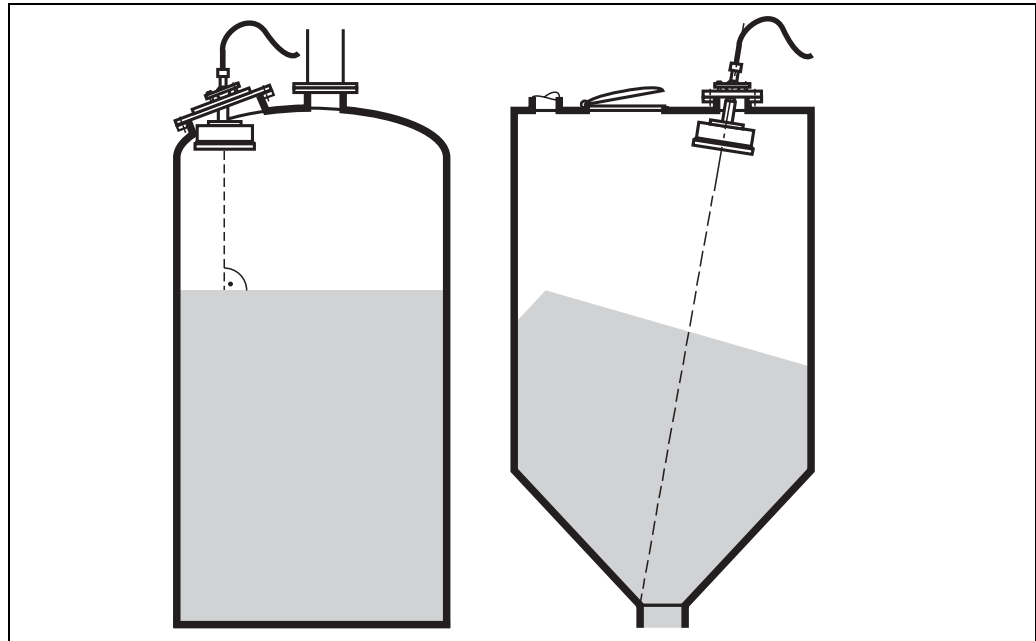

L00-FAU40xxx-17-00-00-xx-001

Installation

The universal flange of the FAU40 alignment unit can be mounted directly onto a DN50 or 2" counterflange if the installation point in the vessel is easily accessible, e.g. through an inspection shaft.

If the installation point is not easily accessible, then a mounting pipe must be chosen that is wide enough to allow the ultrasonic sensor to pass easily through it. Screw or weld the small flange of the alignment unit to the appropriate intermediate flange.

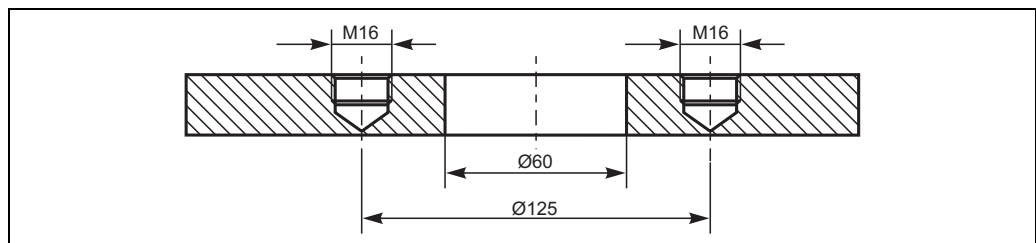

L00-FAU40xxx-06-00-00-xx-002

Example of a customer supplied intermediate flange, e.g. DN200 or DN250; contains 4 blind threaded bores, each set at 90°

Positioning

- The sensor can be oriented laterally (pivoted) by simply loosening the 13AF hexagonal screw on the flange ring.
- In a few cases it might be necessary to adjust the height.



Caution!

Adjust the sensor only when there is no pressure in the vessel.

Loosen the two AF4 Allen screws (grub screws) on the pipe.

- Push the sensor as far down as possible until its lower edge is below the roof of the silo or tank.
- Note that the distance between the maximum level and the lower edge of the sensor must at least be that of the blocking distance.
- Tighten the screws once the sensor has been correctly aligned!
- After each height adjustment we recommend that the area where the pipe goes through the sleeve is packed with sealant (e.g. putty, resin, varnish) to ensure protection IP65.

Technical Data

Dimensions

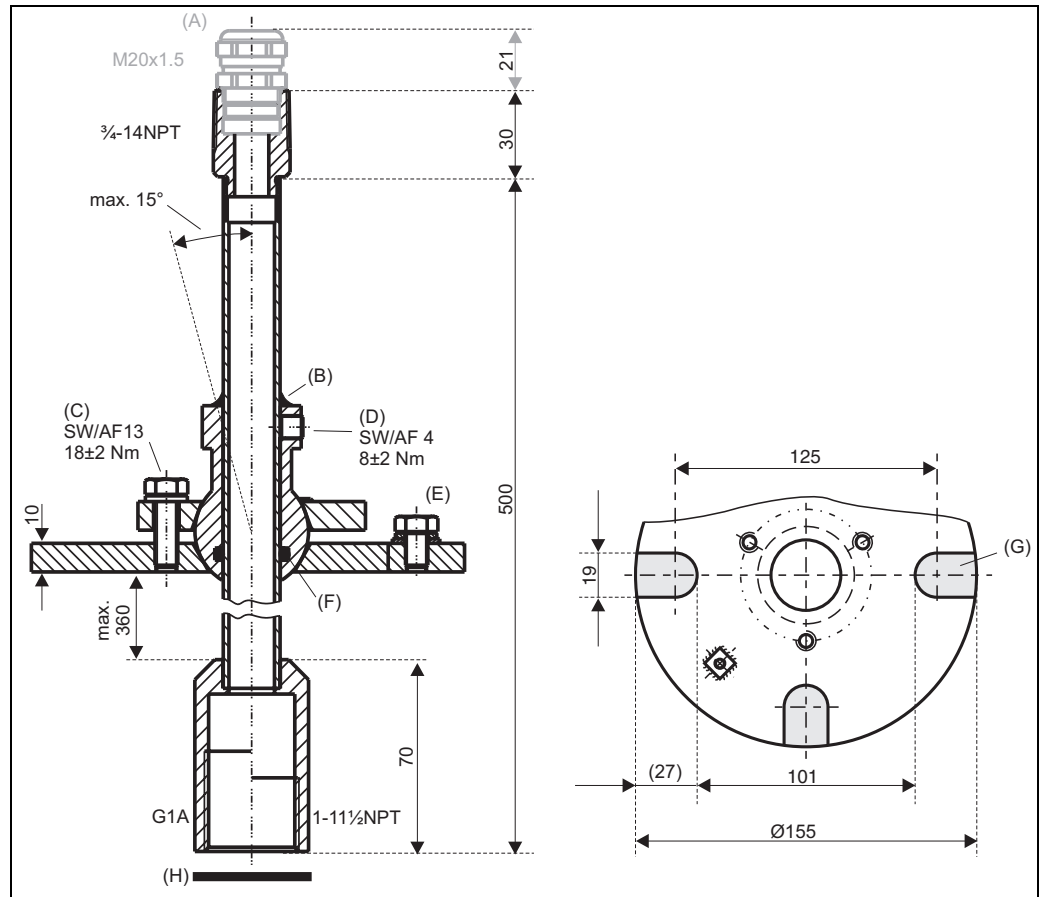

(A): Cable gland M20x1.5 (present if selected in the product structure); (B): sealant here; (C): screw for lateral movement; (D): two Allen screws for height adjustment; (E): ground pin; (F): O-ring; (G): mounting grooves (present in the UNI flange); (H): seal supplied with the sensor; must be used for applications in ATEX zone 20

Materials

Flange	304
Pipe	galvanized steel
Cable gland	304 or galvanized steel (s. product structure)

Weight

approx. 2,5 kg

Ingress protection

IP65

Process conditions

for unpressurized applications only

Product structure

010	Process Connection (Flanges)
1	Welding flange, 304
2	UNI flange, 2" / DN50/50, 304, max. 1.5 bar abs. / 22psia; suitable for 2" 150lbs / DN50 PN16 / 10K 50
020	Sensor Connection
S	Thread G1, gland M20, 304
G	Thread G1, gland M20, steel zinc coated
N	Thread NPT1, entry 3/4, steel zinc coated
FAU40 -	product designation

International Head Quarter

Endress+Hauser
GmbH+Co. KG
Instruments International
Colmarer Str. 6
79576 Weil am Rhein
Deutschland

Tel. +49 76 21 9 75 02
Fax +49 76 21 9 75 34 5
www.endress.com
info@ii.endress.com

Endress+Hauser 

People for Process Automation

