

# RTD Temperature Sensor *omnigrad T TR 25*

**Thermometer without extension neck  
Threaded connection under the head  
PCP (4...20 mA), HART® or PROFIBUS-PA® electronics**



Temperature sensors TR 25, series Omnigrad T, are resistance thermometers suitable for almost all industrial processes and generic applications thanks to their modular structure.

They are made up of a measurement probe without a protection well and a housing, which may contain the transmitter for conversion of the variable measured.

## Features and benefits

- SS 316L/1.4404 for "wetted" parts
- The most common threaded process connections as standard; others are available upon request
- Insert (not replaceable) in mineral oxide with a diameter of 6 mm
- Customized immersion length
- Probe end with reduced diameter for a faster response time
- Surface finishing  $R_a < 0.8 \mu\text{m}$
- Stainless steel, aluminium or plastic housing, with protection grade from IP65 to IP67
- PCP (4...20 mA, also with enhanced accuracy), HART® and PROFIBUS-PA® 2-wire transmitters
- Pt 100 sensing element with class A accuracy (DIN EN 60751) or 1/3 DIN B
- Pt 100 wire wound (-200...600°C) or thin film (-50...400°C)
- Double Pt 100, for redundancy purposes
- Single Pt 100 with 4 wires connection, double Pt 100 with 3 wires
- EA calibration certificate

# Endress + Hauser

The Power of Know How



## Areas of application

- Fine chemicals industry
- Light energy industry
- General industrial services
- Environmental engineering

## Function and system design

### Measuring principle

In the RTD (Resistance Temperature Detector) thermometers, the sensing element consists of an electrical resistance with value of  $100\ \Omega$  at  $0^\circ\text{C}$  (called Pt 100, in compliance with standard DIN EN 60751) which increases at higher temperatures according to a coefficient characteristic of the resistor material (platinum). In industrial thermometers that comply with the DIN EN 60751 standard, the value of this coefficient is  $\alpha = 3.85 \cdot 10^{-3}\ \text{C}^{-1}$ , calculated between 0 and  $100^\circ\text{C}$ .

### Equipment architecture

The Omnigrad T TR 25 temperature sensor is made up of a measurement probe and a housing (head), which may contain a transmitter or the terminals on the ceramic block for electrical connection.

The sensor is manufactured according to standards DIN 43729 (housing) and 43735 (probe) and can therefore guarantee a good adaptability to the most common industrial processes.

The measurement probe consists of a mineral insulated insert (non replaceable) with a diameter of 6 mm and an end part that can also be reduced.

The TR 25 can be fitted onto the plant (tube or vessel) by means of a threaded root fitted below the head, which can be chosen from the most common models (see section "Structure of the components").

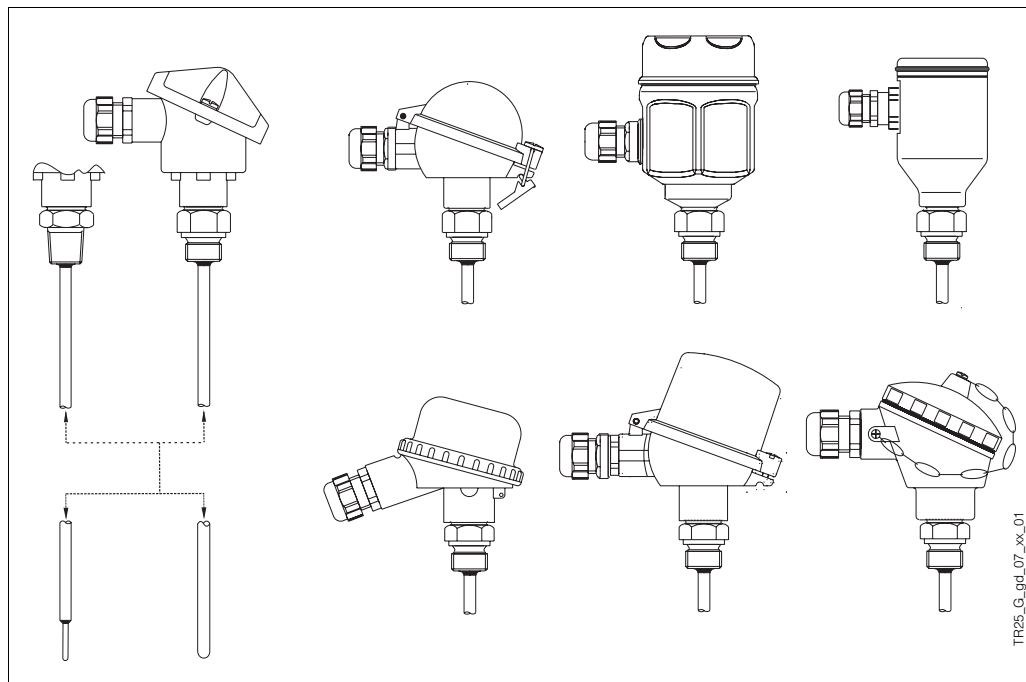

Fig. 1: TR 25 with the various types of heads, process connections and end parts of the probe

The electrical structure of the thermometer always complies with DIN EN 60751 standard rules. The sensing element is available in two versions with a thin film (TF) or wire wound (WW), the latter with a large measurement and accuracy range.

The housing can be of different types and materials (plastic, painted aluminium alloy, stainless steel). The way in which it fits to probe and the cable gland ensure a minimum grade of IP65 (Ingress Protection).

**Material** Wetted parts in SS 316L/1.4404.

**Weight** From 0.5 to 2 kg for standard options.

## Electronics

The required type of output signal can be obtained by choosing the correct head-mounted transmitter. Endress+Hauser supplies "state-of-the-art" transmitters (the iTEMP® series) built in 2-wire technology and with 4.20 mA output signal, HART® or PROFIBUS-PA®. All of the transmitters can be easily programmed using a personal computer through the ReadWin® 2000 and FieldCare public domain softwares (for transmitters 4.20 mA and HART®) or the CommuWin II software (for PROFIBUS-PA® transmitters). The HART® transmitters can also be programmed with the hand-held operating module DXR 275 (Universal HART® Communicator).

A PCP (4.20 mA, TMT 180) model with enhanced accuracy is available.

In the case of PROFIBUS-PA® transmitters, E+H recommends the use of PROFIBUS® dedicated connectors. The Weidmüller type (Pg 13.5 - M12) is provided as a standard option.

For detailed information about transmitters, please refer to the relevant documentation (refer to the TI codes at the end of the document).

If a head-mounted transmitter is not employed, the sensor probe can be connected through the terminal block to a remote converter (i.e. DIN rail transmitter).

## Performance

### Operating conditions

Ambient temperature (housing without head-mounted transmitter)

- metal housings -40÷130°C
- plastic housings -40÷85°C

Ambient temperature (housing with head-mounted transmitter) -40÷85°C

Ambient temperature (housing with display) -20÷70°C

Process temperature

Same of measurement range (see below).

Maximum process pressure

4 MPa (40 bar) at 20°C

Maximum flow velocity

The highest flow velocity tolerated by the insert stem diminishes with increasing lengths of the probe exposed to the stream of the fluid.

Shock and vibration resistance

According to DIN EN 60751

3 g peak / 10÷500 Hz

### Accuracy

Probe maximum error (type TF)

- cl. A
 

$3\sigma = 0.15 + 0.0020 t $	-50..250°C
$3\sigma = 0.30 + 0.0050 t $	250..400°C
- cl. 1/3 DIN B
 

$3\sigma = 0.10 + 0.0017 t $	0..100°C
$3\sigma = 0.15 + 0.0020 t $	-50...0 / 100...250°C
$3\sigma = 0.30 + 0.0050 t $	250..400°C

( $\pm 3\sigma$  = range including 99.7% of the readings,  
|t| = absolute value of the temperature in °C)

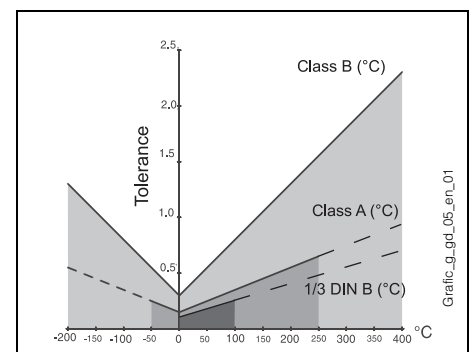



In pipes of a small section the axis line of the duct must be reached and if possible slightly exceeded by the tip of the probe (refer to fig. 2A-2B). Insulation of the outer part of the sensor reduces the effect produced by a low immersion. Another solution may be a tilted installation (see fig. 2C-2D). For use in the food industry, it is best to follow the rule  $h \leq d/2$ .

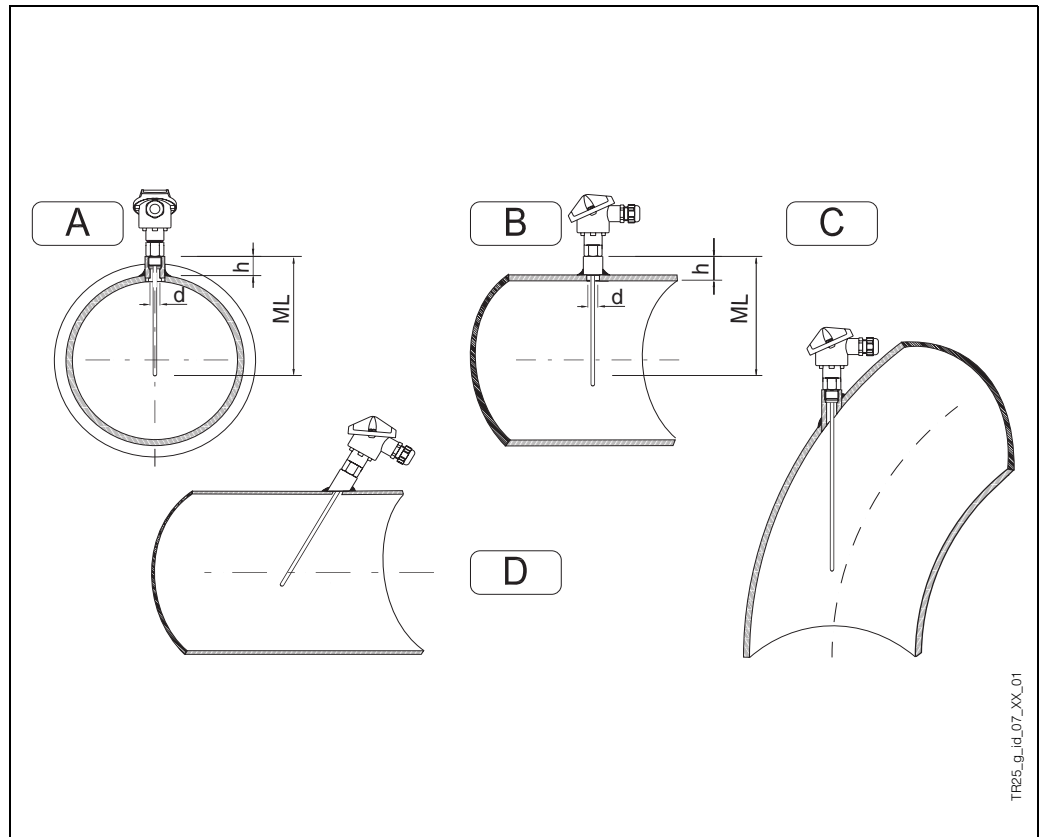

Fig. 2: Installation examples

In the case of two-phase flows, pay special attention to the choice of measurement point, as there may be fluctuations in the value of the detected temperature.

With regard to corrosion, the basic material of the wetted parts (SS 316L/1.4404) can tolerate the common corrosive media up to even the highest temperatures. For further information on specific applications, please contact the E+H Customer Service Department.

In the case that the sensor components are disassembled, in the following reassembly procedure the definite torques must be employed. This will assure the housings with the IP grade protection defined.

When the surrounding environment has a high humidity rate and the process is at low temperature, a plastic housing is recommended (i.e. model TA20B) to avoid problems due to condensation.

In the case of vibrations the thin film sensing element (TF) may offer advantages, but the behaviour depends on the intensity, the direction and the dominating frequency in the vibration mode. The wire wound Pt 100 (WW), besides having a larger measurement and accuracy range, guarantees greater long term stability.

## System components

### Housing

The housing, which contains the electric terminals or the transmitter, is available in different types and materials, e.g. plastic, painted aluminium alloy and stainless steel. The coupling method with the rest of the probe and the cable gland, ensures a minimum IP65 protection grade (refer also to fig. 3).

All available heads have internal geometry according to DIN 43729 standard (form B), and thermometer connection M24x1.5.

Head type TA20A is the basic E+H aluminium housing for temperature sensors. It is supplied in the E+H corporate colours, without any extra charge.

Head TA20B is a black polyamide housing, sometimes referred to as the BBK in the "Temperature" market.

A screw cap is employed in TA21E and is joined to the head body by a chain.

The TA20D head (aluminium), also referred to as BUZH, is able to contain a board and a transmitter or two transmitters at the same time. The order of the double transmitter must be carried out by choosing the option "flying wires" in the sales structure, and two transmitters in a separate position (THT1, see the table at the end of the document).

The TA20J head is a stainless steel housing used in other instruments made by E+H and can be provided with a LCD display (4 digits), which operates with 4.20 mA transmitters.

The TA20R is normally recommended by the Temperature division of E+H for hygienic applications.

The TA20W (BUS type) is a round blue/grey coloured head made of aluminium, with a clip for the cap closure.

The cable gland M20x1.5 provided with the housings, is compatible with cables of a diameter between 5 and 9 mm.

Housing type	IP	Housing type	IP	Housing type	IP	Housing type	IP
 TA20A TA20A_g_dd_00_xx_01	66 67	 TA20B TA20B_g_dd_00_xx_01	65	 TA20R TA20R_g_dd_00_xx_01	66 67	 TA20W TA20W_g_dd_00_xx_01	66
 TA20J TA20J_g_dd_00_xx_01	66 67	 TA20J (display) TA20J_g_dd_00_xx_02	66 67	 TA20D TA20D_g_dd_00_xx_01	66	 TA21E TA21E_g_dd_00_xx_01	65

Fig. 3: Housings and relative IP grade

### Head transmitter

The head-mounted transmitters available are (also refer to the "Electronics" section):

- TMT 180 PCP 4.20 mA
- TMT 181 PCP 4.20 mA
- TMT 182 Smart HART®
- TMT 184 PROFIBUS-PA®

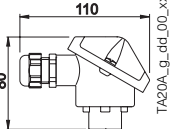
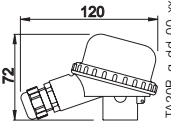
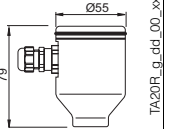
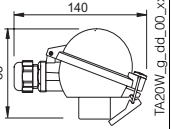
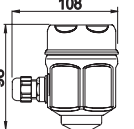
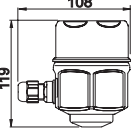
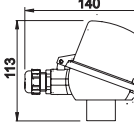
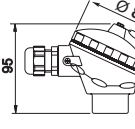
The TMT 180 and the TMT 181 (see fig. 4) are PC programmable transmitters.

The TMT 180 is also available in a version with enhanced accuracy (0.1°C vs. 0.2°C) in the temperature range -50..250°C, and in a version with a fixed measurement range (specified by the customer in the order phase).

The TMT 182 output consists of 4.20 mA and HART® superimposed signals.

For the TMT 184 (see fig. 5), with PROFIBUS-PA® output signal, the communication address may be set via software or via mechanical dip-switch. The customer may specify the configuration desired during the order phase.

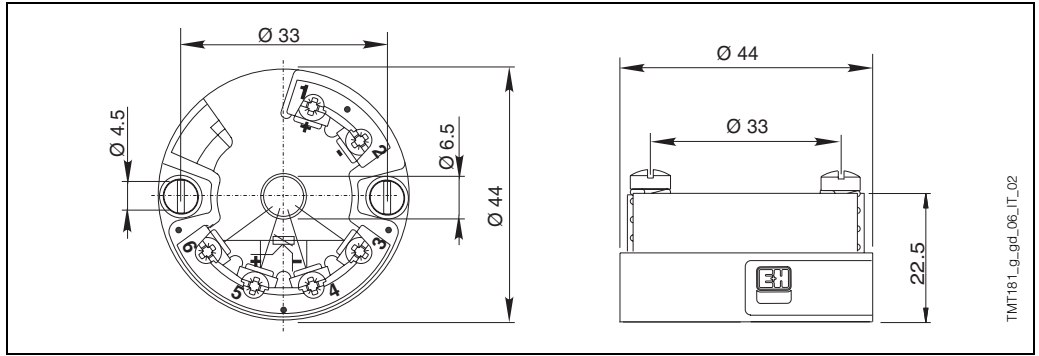

Fig. 4: TMT 180-181-182

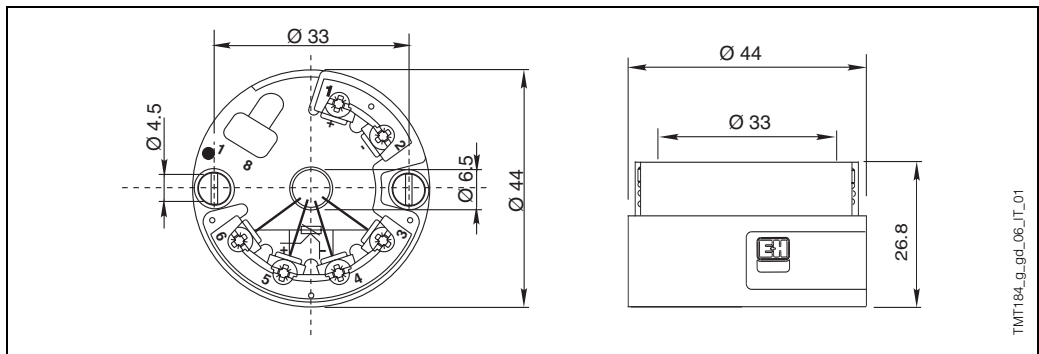

Fig. 5: TMT 184

**Process connection**

Standard connections are available in the following types:

- G 1/2" BSP (cylindrical)
- 1/2" NPT.

Other versions may be supplied upon request.

Figure 6 shows the screwing lengths.

Process connection	Thread	C (mm)
<p>Diagram showing process connections for Gas and NPT. The diagram includes dimensions L1, C, and L. The thread sizes are M24x1.5.</p>	1/2" NPT	8
	G 1/2" DIN	15

Fig. 6: Process connection

**Probe**

On TR 25 the measurement probe is constituted by a non replaceable mineral insulated insert (MgO).

The immersion length is available in the most commonly used dimensions or can be personalized by the customer within a range of values (refer to "Sales Structure" at the end of the document). Although the wiring diagram of single Pt 100 is always supplied with 4 wires configuration, the connection of a transmitter can be executed with 3 wires as well, by avoiding to connect whichever of the terminals.

The use of a TR 25 with standard lengths ensures fast delivery times; this allows our customers to reduce the amount of spare parts to be kept on stock.

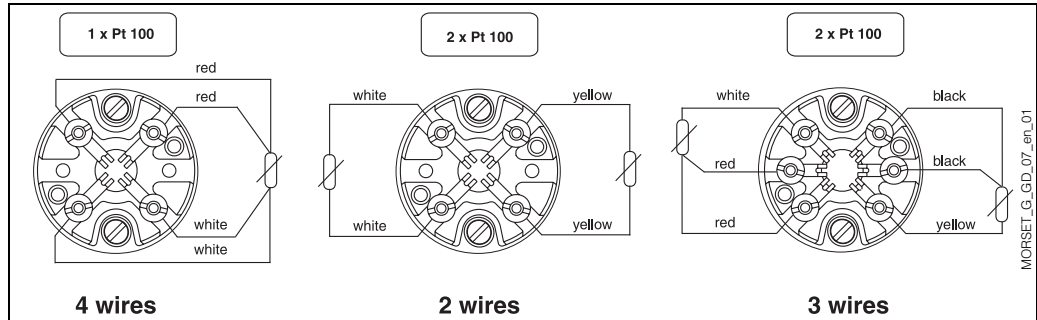

Fig. 7: Standard electrical diagrams (ceramic terminal block)

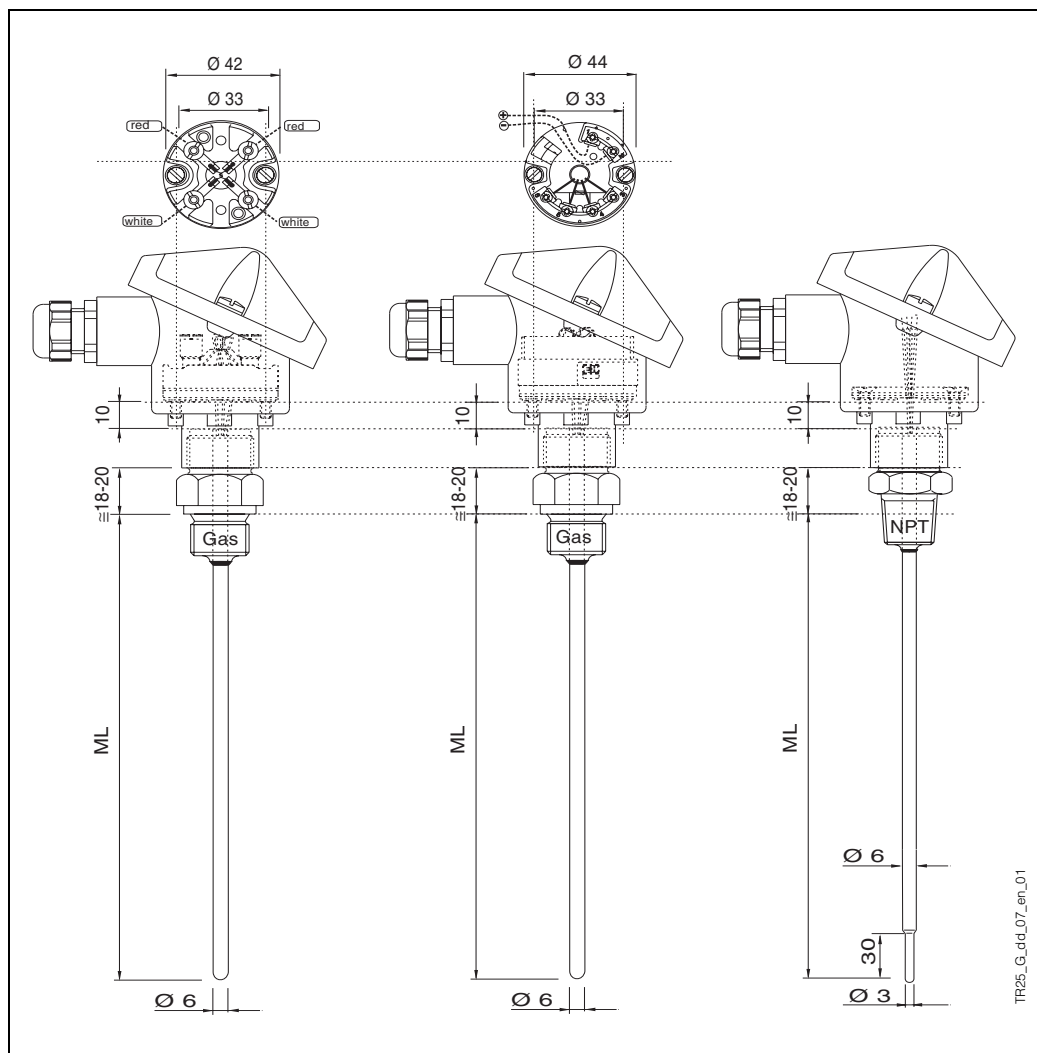

Fig. 8: Functional components



## Certificates & Approvals

**PED approval** The Pressure Equipment Directive (97/23/CE) is respected. As paragraph 2.1 of article 1 is not applicable to these types of instruments, the CE mark is not requested for the TR 25 destined for general use.

**Material certification** Material certifications can be requested separately.

**Test report and calibration** With regards to the tests and calibration, the "Inspection Report" consists of a compliance declaration for the essential points of the standard DIN EN 60751.  
The "Factory calibration" is carried out in an authorised laboratory EA (European Accreditation) of E+H according to an internal procedure.  
The "Evaluation test report" is a calibration that can be applied to sensors with a low immersion length (see the table below). In this case the procedure accuracy cannot be evaluated due to the low immersion.  
A calibration may be requested separately according to an accredited procedure EA (SIT calibration).

	Temperature range	Minimum immersion length (ML)
Factory calibration	-80...-40°C	260 mm
	-40...0°C	160 mm
	0...250°C	120 mm
	250...550°C	300 mm
Evaluation test report	0...140°C	50 mm

## Further details

**Maintenance** The Omnigrad T thermometers do not require any specific maintenance.  
In the case of ATEX certified components (transmitter) please refer to the corresponding specific relevant documentation (refer to the code at the end of the document).

**Delivery time** For small quantities (approximately 10 units) and standard options, between 10 and 15 days depending on the configuration required.

## Ordering information

### Sales structure

TR25-		Safety (Ex) certification	
A		Ex	certification not required
Y			Special version
Head material, conduit, IP grade			
A		TA20A	Aluminium, conduit M20x1.5, IP66/IP67
4		TA20A	Aluminium, PROFIBUS® connector, IP66
2		TA20A	Aluminium, conduit 1/2" NPT, IP66/IP67
7		TA20B	Polyamide, black, conduit M20x1.5, IP65
E		TA21E	Aluminium, screw cap, M20x1.5, IP65
6		TA20D	Aluminium, high lid, conduit M20x1.5, IP66
5		TA20D	Aluminium, high lid, PROFIBUS® connector, IP66
8		TA20D	Aluminium, high lid, conduit 1/2" NPT, IP66
J		TA20J	SS316L, conduit M20x1.5, IP66/IP67
K		TA20J	SS316L, with display, conduit M20x1.5, IP66/IP67
M		TA20J	SS316L, PROFIBUS® connector, IP66
R		TA20R	SS316L, screw cap, conduit M20x1.5, IP66/IP67
S		TA20R	SS316L, screw cap, PROFIBUS® connector, IP66
W		TA20W	Aluminium, round lid, clip, conduit M20x1.5, IP66
Y			Special version
Diameter and material of probe			
2		Diam.	6 mm, SS 316L/1.4404
8		Diam.	6 mm, reduced 3x30mm, SS 316L/1.4404
Process connection			
<i>(Material of process connection: SS 316L/1.4404)</i>			
1			Process connection G1/2 BSP (cylin.)
2			Process connection 1/2" NPT
9			Special version
Immersion length ML (30-3700 mm)			
A			50 mm, immersion length ML
B			80 mm, immersion length ML
D			100 mm, immersion length ML
F			150 mm, immersion length ML
H			200 mm, immersion length ML
X			... mm immersion length ML to specify
Y			... mm special immersion length ML
Terminal type or built-in transmitter			
F			Flying leads
C			Ceramic terminal block
2		TMT180-A21,	fixed range from...to...°C, accuracy 0.2 K, span limit -200...650°C
3		TMT180-A22,	fixed range from...to...°C, accuracy 0.1 K, span limit -50...250°C
4		TMT180-A11,	programmable, from...to...°C, accuracy 0.2 K, span limit -200...650°C
5		TMT180-A12,	programmable, from...to...°C, accuracy 0.1 K, span limit -50...250°C
P		TMT181-A,	PCP, programmable from ...to ...°C, 2-wire isolated
Q		TMT181-B,	PCP ATEX, programmable from ...to ...°C, 2-wire isolated
R		TMT182-A,	HART®, programmable from ...to ...°C, 2-wire isolated
T		TMT182-B,	HART®ATEX, programmable from ...to ...°C, 2-wire isolated
S		TMT184-A,	PROFIBUS-PA® programmable from ...to ...°C, 2-wire isolated
V		TMT184-B,	PROFIBUS-PA®ATEX, programmable from ...to...°C, 2-wire isolated
RTD type, temperature range, wiring diagram			
3		1 Pt 100, TF	Class A, -50/400°C 4 wires
7		1 Pt 100, TF	Class 1/3 DIN B, -50/400°C 4 wires
C		1 Pt 100, WW	Class A, -200/600°C 4 wires
G		1 Pt 100, WW	Class 1/3 DIN B, -200/600°C 4 wires
B		2 Pt 100, WW	Class A, -200/600°C 3 wires
F		2 Pt 100, WW	Class 1/3 DIN B, -200/600°C 3 wires
Y			Special version
Material certification			
0			Material certification not requested
9			Special version
Test and calibration			
0			Test and calibration not requested
1			Inspection report on sensor
2			Inspection report on loop
A			Factory calibration, single RTD, 0-100°C



---

## Supplementary documentation

---

<input type="checkbox"/> RTD thermometers Omnigrad TST - General information	TI 088T/02/en
<input type="checkbox"/> Terminal housings - Omnigrad TA 20	TI 072T/02/en
<input type="checkbox"/> Temperature head transmitter iTEMP®Pt TMT 180	TI 088R/09/en
<input type="checkbox"/> Temperature head transmitter iTEMP®PCP TMT 181	TI 070R/09/en
<input type="checkbox"/> Temperature head transmitter iTEMP®HART®TMT 182	TI 078R/09/en
<input type="checkbox"/> Temperature head transmitter iTEMP®PA TMT 184	TI 079R/09/en
<input type="checkbox"/> E+H Thermolab - Calibration certificates for industrial thermometers <i>RTD's and thermocouples</i>	TI 236T/02/en

**Subject to modification**

---

Endress+Hauser GmbH+Co. KG  
Instruments International  
P.O. Box 2222  
D-79574 Weil am Rhein  
Germany

Tel. +49 7621 975 02  
Fax +49 7621 975 345  
<http://www.endress.com>  
[info@ii.endress.com](mailto:info@ii.endress.com)

---

Endress + Hauser  
The Power of Know How

