

Technical Information

Tophit CPS441 and CPS441D

ISFET sensor with liquid KCl reference electrode for pH measurement in blocking media

Analog or digital sensors with Memosens technology



Application

Special applications for:

- Maximum measuring accuracy
- Blocking media (pressurized)
- High organic solvent contents
- Low conductivities

With ATEX, FM and CSA approval for application in hazardous areas

Your benefits

- Resistant to breaking
 - Sensor body made completely of PEEK (FDA compliant)
 - Direct installation into the process, reduces effort and costs for sampling and laboratory analysis
- Re-fillable liquid KCl reference electrolyte
- Application possible at low temperatures
 - Short response time
 - Constantly high accuracy
- Sterilizable
- Longer calibration intervals than glass electrodes
 - Lower hysteresis with alternating temperatures
 - Low measuring error after high-temperature loading
 - Almost no acid and alkaline errors
- With built-in temperature sensor for effective temperature compensation
- Ideal for CIP processes when combined with an automatic retractable assembly

Further benefits offered by Memosens technology

- Maximum process safety through contactless inductive signal transmission
- Data safety through digital data transmission
- Easy handling thanks to storage of sensor-specific data in the sensor
- Predictive maintenance possible thanks to registration of sensor load data in the sensor

Function and system design

Measuring principle

Ion-**selective**, or more generally ion-**sensitive** field effect transistors (ISFET) were developed in the 1970s as an alternative to the glass electrode for pH measurement.

Basics

Ion-selective field effect transistors use an MOS¹⁾ transistor arrangement (see Fig 1) where the metallic gate (pos. 1) is not a control electrode. Instead, the medium (see Fig 2, pos. 3) in the ISFET is in direct contact with the gate isolator layer (pos. 2). Two strongly N-conducting areas are diffused in P-conducting substrate (see Fig 2, pos. 5) of the semiconductor material (Si). These N-conducting areas are current supplying ("Source", S) and current accepting ("Drain", D) electrodes. The metallic gate electrode (in case of the MOSFET) resp. the medium (in case of the ISFET) forms a capacitor with the substrate below. A potential difference between gate and substrate (U_{GS}) causes a higher electron density between "Source" and "Drain". A N-conducting channel (pos. 2) is formed, i.e. a drain current (I_D) is induced.

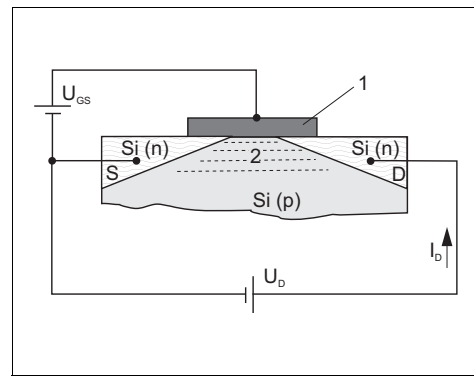

Fig. 1: Principle MOSFET

- 1 Metallic gate
- 2 N-conducting channel

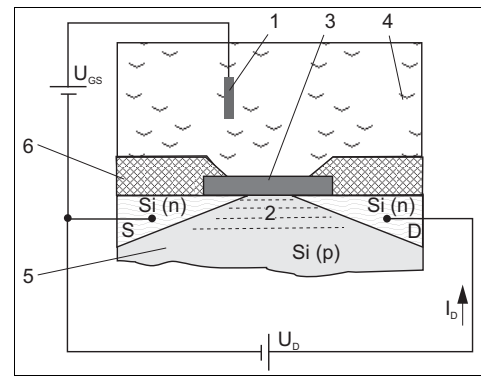

Fig. 2: Principle ISFET

- 1 Reference electrode
- 2 N-conducting channel
- 3 Gate isolator layer
- 4 Medium
- 5 P-doped silicon substrate
- 6 Sensor shaft

With the ISFET, the medium is in direct contact with the gate isolator layer. Therefore, H^+ ions available in the medium, which are located in the medium / gate isolator boundary layer, create the electric field (gate potential). Depending on the effect described above, a N-conducting channel is formed and a current between "Source" and "Drain" is induced. Suitable sensor circuits use the dependence on the ion-selective gate potential to create an output signal proportional to the concentration of the ion type.

pH selective IsFET

The gate isolator serves as an ion-selective layer for H^+ ions. The gate isolator is impermeable to the ions as well (isolator effect) but allows reversible surface reactions with the H^+ ions.

Depending on the acidic or alkaline character of the measurement solutions, functional groups in the isolator surface accept or reject H^+ ions (amphoteric character of the functional groups). This leads to a positive (H^+ acceptance in the acidic medium) or negative (H^+ rejection in the alkaline medium) charging of the isolator surface. Depending on the pH value, a defined surface charge can be used to control the field effect in the channel between "Source" and "Drain". The processes which lead to the creation of a charge potential and therefore to a control voltage U_{GS} between "Gate" and "Source" are described with the Nernst equation:

$$U_{GS} = U_0 + \frac{2.3 \cdot RT}{nF} \cdot \lg a_{ion}$$

U_{GS} ... Potential between gate and source
 U_0 ... Offset voltage
 R ... Gas constant (8.3143 J/molK)
 T ... Temperature [K]
 n ... electrochemical valueability (1/mol)

F ... Faraday constant (26.803 Ah)
 a_{ion} ... Activity of ion kind (H^+)

$\frac{2.3 \cdot RT}{nF}$ Nernst factor

At 25 °C (77 °F), the Nernst factor is -59.16 mV/pH.

1) Metal Oxide Semiconductor

Important characteristics of Tophit CPS441

- **Resistance to breaking:** This is the most obvious feature of the sensor. The complete sensor technology is embedded in a PEEK shaft. Only the highly resistant isolator layer and the reference have direct contact with the medium.
- **Acid or alkaline errors:** A further, important benefit compared with the glass electrode is the considerably reduced number of acid or alkaline errors in extreme pH ranges. In contrast to glass electrodes, practically no foreign ions can build up at the ISFET gate. The measuring error of < 0.01 pH (between pH 1 and 13) at 25°C (77°F) is near by the detection limit.

The figure below shows the acid or alkaline error of the ISFET between pH 1 and 13 and the comparison to the glass electrode (two different pH glasses) at pH values 0.09 and 13.86.

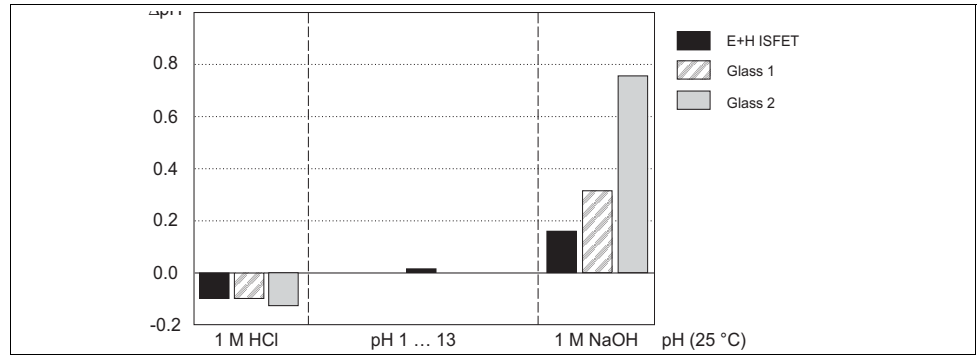

Fig. 3: Comparison of acid and alkaline errors

- **Measurement stability and sensor response time:** The ISFET response times are very short over the whole temperature range. With the ISFET sensor, there is no (temperature-dependent) equilibrium setting as in the source layer of a pH glass of a glass electrode. They can also be used at low temperatures without a deceleration in response time. Large and fast temperature and pH value fluctuations have a smaller effect on the measuring error (hysteresis) than with a glass electrode, as there is no stress exerted on the pH glass.
- **Reference system:** The integrated reference electrode of the sensor is a double-chamber reference system with a bridge electrolyte. The benefits are an efficient and stable contact between the diaphragm and the reference lead, and the extremely long poisoning path. The bridge electrolyte is highly resistant to temperature and pressure changes.
- **Isothermic curves**
 - The Nernst equation defines the dependence of the measuring voltage on the hydrogen ion content (pH value) and the temperature. It is the basis of pH measuring technology and for ISFET sensors too. A temperature-dependent value for the potential change per pH value can be worked out from this equation (isothermic curve, potential change per pH value at a defined temperature).
 - The isothermic curves of the ISFET sensor are very close to the theoretical values (see Fig 4). This is further proof for the high pH measurement precision of the sensor.

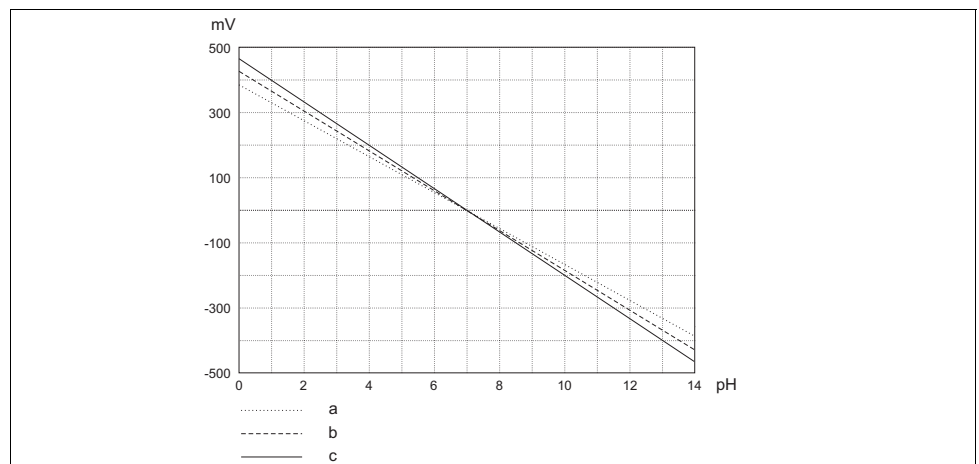

Fig. 4: Isothermic curves

- a Isothermic curve at 8°C (46°F), slope -55.8 mV/pH
- b Isothermic curve at 37°C (99°F), slope -61.5 mV/pH
- c Isothermic curve at 61°C (142°F), slope -66.3 mV/pH

Memosens (CPS441D)**Maximum process safety**

The inductive and non-contacting measured value transmission of Memosens guarantees maximum process safety and offers the following benefits:

- All problems caused by moisture are eliminated.
 - The plug-in connection is free from corrosion.
 - Measured value distortion from moisture is not possible.
 - The plug-in system can even be connected under water.
- The transmitter is galvanically decoupled from the medium. The result: No more need to ask about "symmetrically high-impedance" or "unsymmetrical" (for pH/ORP measurement) or an impedance converter.
- EMC safety is guaranteed by screening measures for the digital measured value transmission.
- Application in explosion-hazardous areas is unproblematic; the integrated electronics are intrinsically safe.

Data safety through digital data transfer

The Memosens technology digitalizes the measured values in the sensor and transfers them to the transmitter contactlessly and free from interference potential. The result:

- An automatic error message is generated if the sensor fails or the connection between sensor and transmitter is interrupted.
- The availability of the measuring point is dramatically increased by immediate error detection.

Easy handling

Sensors with Memosens technology have integrated electronics that allow for saving calibration data and further information such as total hours of operation and operating hours under extreme measuring conditions. When the sensor is mounted, the calibration data are automatically transferred to the transmitter and used to calculate the current measured value. Storing the calibration data in the sensor allows for calibration away from the measuring point. The result:

- Sensors can be calibrated under optimum external conditions in the measuring lab. Wind and weather do neither affect the calibration quality nor the operator.
- The measuring point availability is dramatically increased by the quick and easy replacement of precalibrated sensors.
- The transmitter does not need to be installed close to the measuring point but can be placed in the control room.
- Maintenance intervals can be defined based on all stored sensor load and calibration data and predictive maintenance is possible.
- The sensor history can be documented on external data carriers and evaluation programs at any time. Thus, the current application of the sensors can be made to depend on their previous history.

Communication with the transmitter

Always connect digital sensors to a transmitter with Memosens technology. Data transmission to a transmitter for analog sensors is not possible.

The sensor is connected to the cable connection (CYK10) without contact. The power and data are transferred inductively

Once connected to the transmitter, the data saved in the sensor are read digitally. You can call up these data using the corresponding DIAG menu.

Data that digital sensors save include the following:

- Manufacturer data
 - Serial number
 - Order code
 - Date of manufacture
- Calibration data
 - Calibration date
 - Calibration values
 - Number of calibrations
 - Serial number of the transmitter used to perform the last calibration
- Operational data
 - Date of commissioning
 - Hours of operation under extreme conditions
 - Number of sterilizations
 - Data for sensor monitoring.

Measuring system

The complete measuring system comprises at least:

- ISFET sensor Tophit
- Measuring cable CPK12 (analog, with TOP68 connection) or CYK10 (digital, with Memosens)
- Transmitter, e.g. Liquiline CM4x, Liquisys CPM223 (for panel mounting) or Liquisys CPM253 (field instrument) or Mycom CPM153.
- Assembly
 - Immersion assembly, e.g. Dipfit CPA111
 - Flow assembly, e.g. Flowfit CPA250
 - Retractable assembly, e.g. Cleanfit CPA471
(CPA450 only with CPS471D, CPS491D or special versions CPS471-ESA and CPS491-ESA, → Ordering information)
 - Fixed installation assembly, e.g. Unifit CPA442

There are additional accessories available depending on the application:

- Topclean CPC30 or Topcal CPC310 automatic cleaning system
- Extension cable, VBA, VBM or RM junction box

Food industry

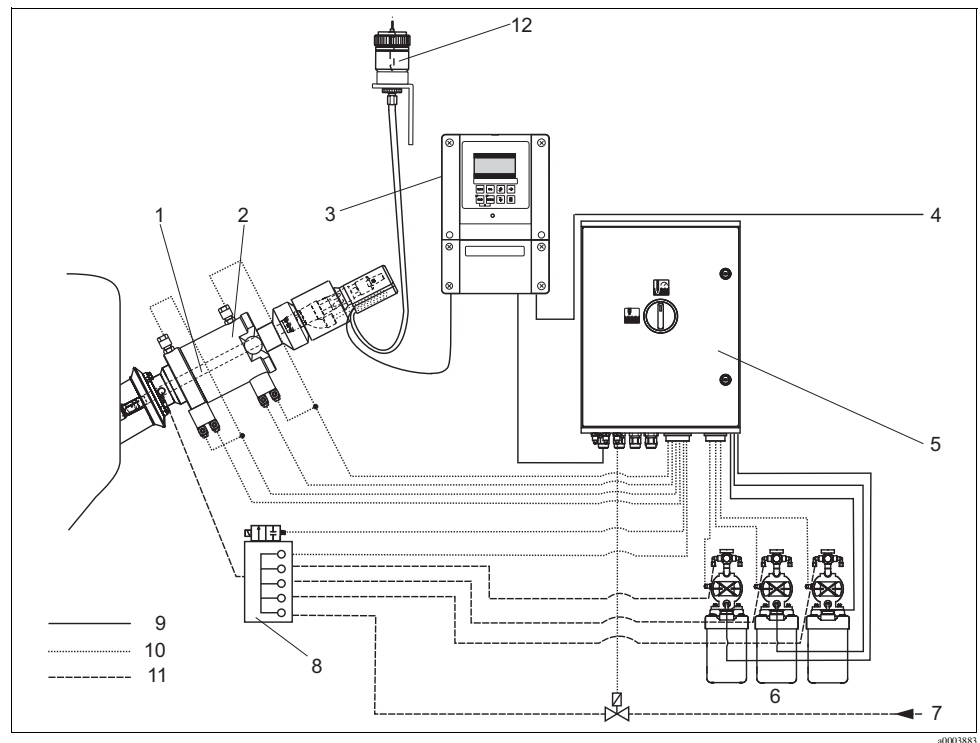

Fig. 5: Measuring system with Topcal fully automatic measuring, cleaning and calibration system

1	Tophit	6	Cleaner, buffer solutions	10	Compressed air
2	Cleanfit CPA475	7	Steam, water, cleaner	11	Liquids / cleaner
3	Mycom CPM153	8	Rinse block	12	CPY7 KCl electrolyte vessel
4	Power supply	9	Power cable		
5	Control unit CPG310				

Process sterilizability is no problem due to the wide range of applications for the ISFET pH sensor, not only relating to temperature but also to pH. There is only a small range of high pH values connected with high temperatures where the sensor is not constantly stable (see "Process"). Media with these characteristics remove the isolator oxide from the ISFET chip. As this is the pH and temperature range of CIP cleaning media, the ISFET pH sensor should only be used in combination with an automatic retractable assembly.

Benefits of the Topcal fully automatic measurement, cleaning and calibration system:

- CIP cleaning
The sensor built into the retractable assembly is automatically "moved" out of the medium before cleaning. In the rinse chamber of the retractable assembly the sensor is cleaned with suitable cleaning solutions.
- Calibration cycles can individually be set.
- Low maintenance costs due to fully automatic cleaning and calibration functions.
- Measuring results are optimally reproducible and the individual value tolerances are very low due to the automatic calibration.

Biotechnology

Fig. 6: Measuring system for pharmaceutical and biotechnology applications

- 1 ISFET sensor
- 2 Installation assembly Unifit CPA442
- 3 KCl electrolyte vessel
- 4 Special measuring cable CPK12 or CYK10
- 5 Transmitter Liquiline CM42

Input

Measured values pH value
Temperature

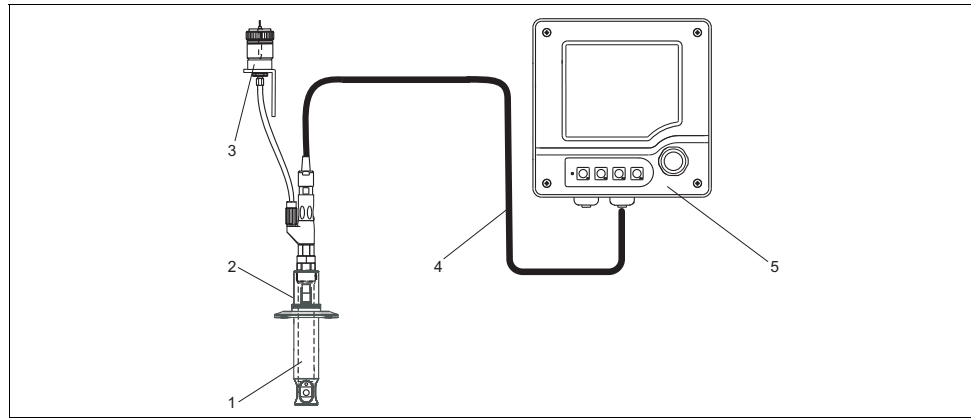
Measuring range 0 to 14 pH
-15 to 135 °C (5 to 275 °F)

Caution!
Note the process operating conditions.

Power supply

Electrical connection CPS441 The sensor is connected to the measuring transmitter using the special measuring cable CPK12.

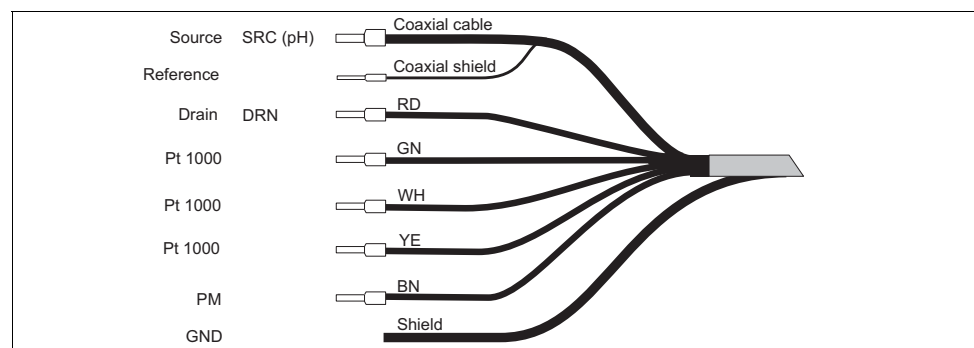

Fig. 7: Special measuring cable CPK12

Note!

- The cable cores Yellow and White are connected on the sensor side.
- Make sure you comply with the instructions for connecting the sensor (wiring diagram) in the Operating Instructions of the transmitter. The transmitter has to be appropriate for the use of ISFET sensors (e.g. Liquiline CM42, Mycom CPM153 or Liquisys CPM223/253-IS).
A transmitter with only a standard pH input is inappropriate.

**Electrical connection
CPS441D**

The sensor is electrically connected to the transmitter by means of the special measuring cable CYK10.

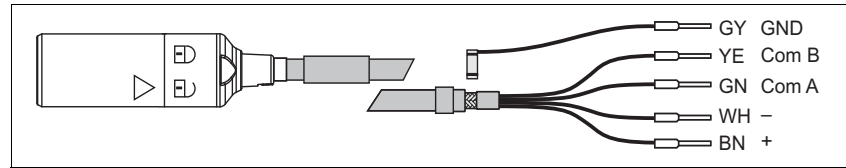

Special measuring cable CYK10

40003350

Performance characteristics

Response time

< 5 s
for buffer change from pH 4 to pH 7 under reference operating conditions

Note!

The response of the integrated temperature sensor can be slower with extreme temperature changes.

Reference operating conditions

Reference temperature: 25 °C (77 °F)
Reference pressure: 1013 mbar (15 psi)

Maximum measured error

pH: ± 0.2 % of measuring range
Temperature: Class B acc. to DIN IEC 60751

Repeatability

± 0.1 % of measuring range

Start-up drift

Everytime when switching on the measuring device a control loop is set up. During this time the measured value moves to the true value.

The settling time depends on the kind of interruption and the interruption time:

- Supply voltage interruption, sensor left in medium: approx. 3 to 5 minutes
- Interruption of the fluid film between pH sensitive ISFET and reference lead: approx. 5 to 8 minutes
- Longer dry storage of the sensor: up to 30 minutes

Installation

Installation angle

ISFET sensors can be installed in any position, as there is no liquid internal lead. However, in case of an overhead installation, a possible air cushion²⁾ in the reference system might interrupt the electrical contact between the medium and the diaphragm.

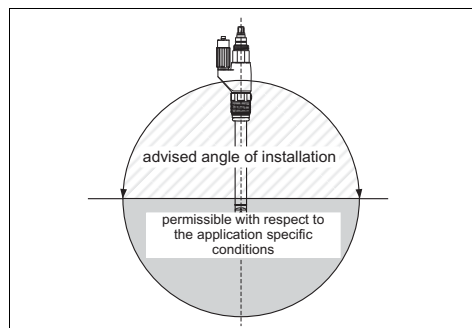

Fig. 8: Angle of installation

Note!

- Especially in case of overhead installation, make sure you connect the KCl electrolyte vessel without air cushions!
- The installed sensor may be held under dry conditions for maximum 6 hours (also applies to overhead installation).
- Make sure you comply with the instructions in the Operating Instructions for the assembly used.

2) The sensor is delivered without air cushions. Air cushion formation is possible in case of working with vacuum, e.g. cleaning out of tanks.

Sensor orientation

When installing the sensor, note the flow-past direction of the medium. The ISFET chip should be fixed at an angle of approx 45° to the flow-past direction (see Fig 10). Fixing at the correct angle is very easy because of the rotatable plug-in head.

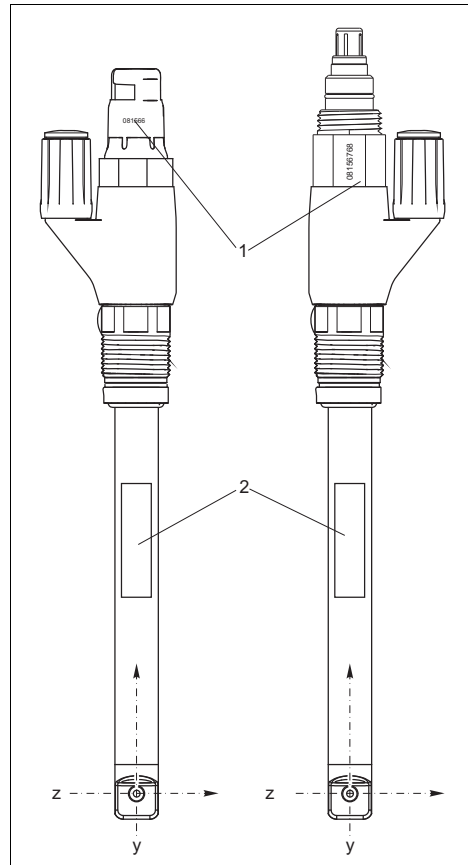

Fig. 9: Sensor orientation, front view

- 1 Serial number
- 2 Nameplate

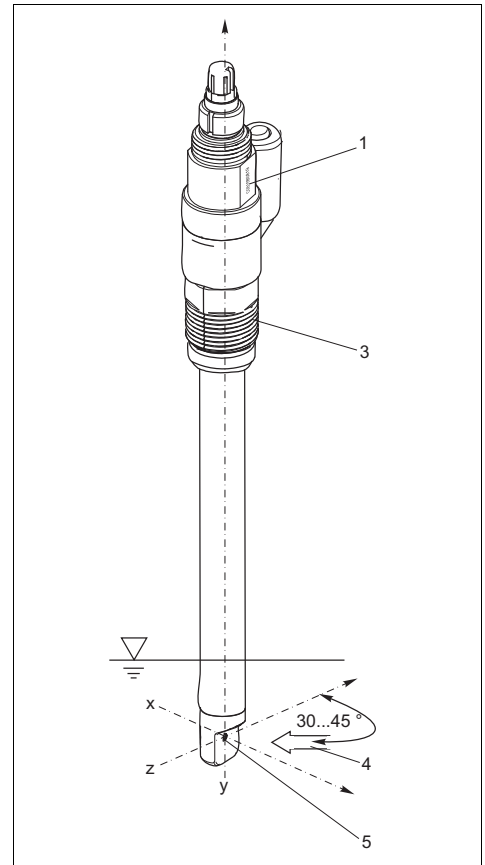

Fig. 10: Sensor orientation, 3d view

- 1 Serial number
- 3 Rotatable part of the connection head
- 4 Medium flow-past direction
- 5 ISFET chip

When installing the sensor in an assembly, use the engraved serial number on the connection head for correct sensor orientation. The serial number is always located in the same plane as the ISFET chip and the nameplate (z-y-direction, see Fig 9).

Note!

ISFET sensors are not designed for the use in abrasive media. If you use them in such applications anyhow, you must avoid direct flow against the chip. This considerably lengthens the service life and improves the drift behavior of the sensor. You have however the disadvantage that the display of the pH value is not stable.

Environment**Ambient temperature range****Caution!**

Danger of frost damage

Do not operate the sensor at temperatures below -15°C (5°F).

Storage temperature

0 to 50°C (32 to 120°F)

Ingress protection

TOP68:

- IP 68, 1 m (3.3 ft) water column, 50°C (122°F), 168 h, autoclavable up to 135°C (275°F)

Memosens:

- IP 68, 10 m (32.8 ft) water column, 25°C (77°F), 45 d, 1M KCl, autoclavable up to 135°C (275°F)

Sensitivity to light

As every semiconductor the ISFET is light-sensitive (fluctuations of measured value). Avoid direct sunlight during calibration and operation!
Normal environment light does not influence the measurement.

Process**Medium temperature depending on pH**

At high temperatures over a long period of time, alkalis irreversibly destroy the gate isolator oxide. The sensor can only be used in the indicated range (see Fig 11) at a cost to its life span. If it is constantly subjected to the effects of a 2% sodium hydroxide solution at 80°C (176 °F), the sensor life span drops to approx. 10-15 hours.

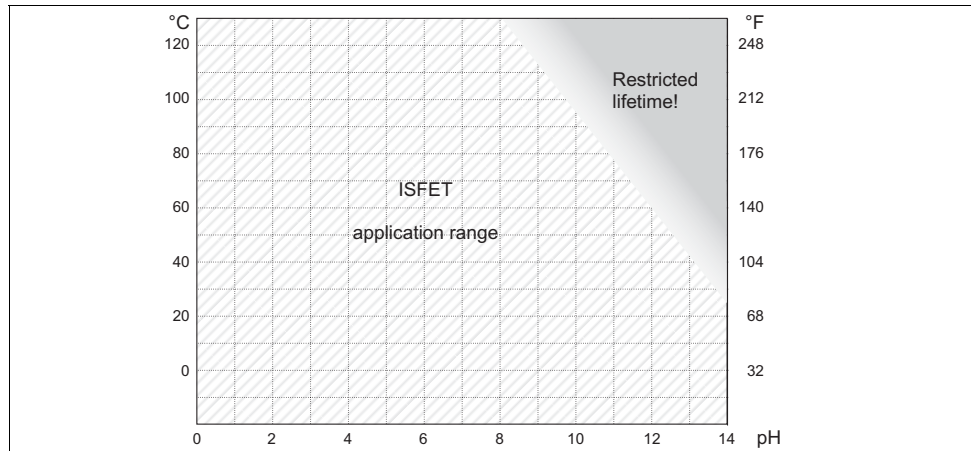

Fig. 11: Temperature and pH

Application at low temperatures

Application range of the sensor according to the order code (see ordering information, product structure)

Pressure-temperature diagram

The process pressure must not be higher than the back pressure to the KCl electrolyte vessel. Otherwise the process pressure effects medium penetration into the KCl electrolyte vessel.

Using the CPY7 electrolyte vessel, the maximum permitted pressure is 10 bar at 20 °C (150 psi at 68 °F). This means, the process pressure has to be lower than 10 bar (150 psi)!

Please, refer to the corresponding chapters in the Operating Instructions of your electrolyte vessel.

Max. 10 bar / 100 °C (145 psi / 212 °F)

Sterilizable: 3 bar / 135 °C (44 psi / 275 °F), 1 h

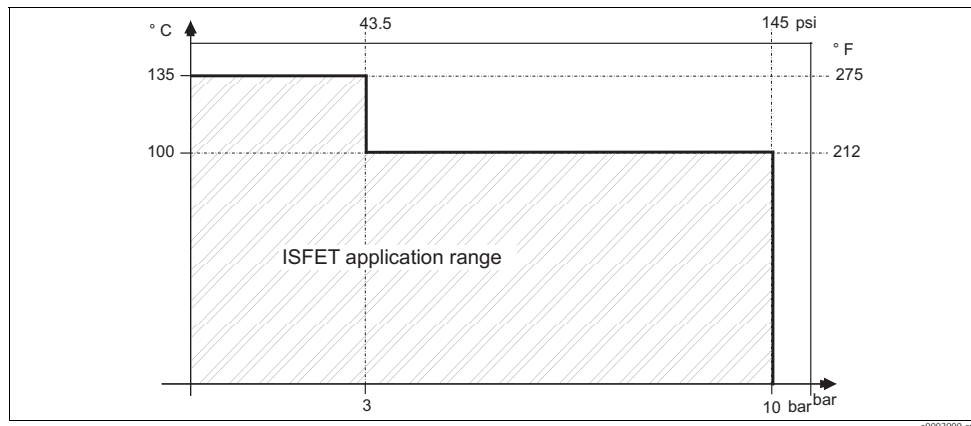

Fig. 12: Pressure and temperature

Caution!

Danger of damage to the sensor

Never use the Tophit for applications outside the given specifications!

- Recommended cleaning**
- Depending on the degree of pollution:
 - Hot water / soap (to be preferred)
 - Isopropanole
 - Chlorine cleaner
 - Storing in KCl solution

Mechanical construction

Design, dimensions

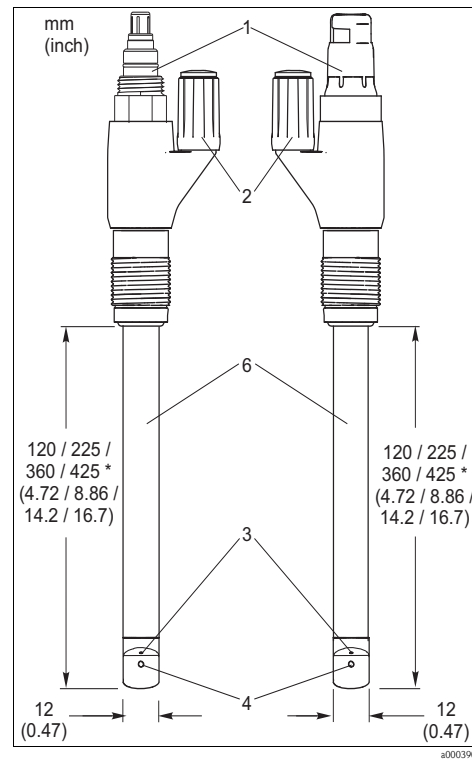

Fig. 13: Tophit CPS441
* depending on the sensor version

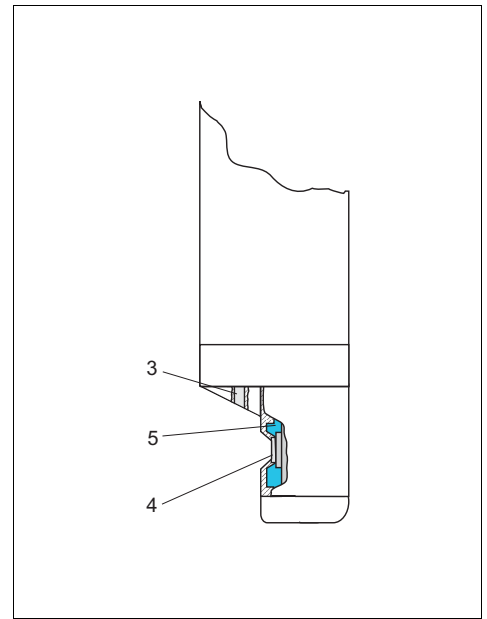

Fig. 14: Sensor head

- 1 KCl electrolyte connection
- 2 Plug-in head
- 3 Reference electrode
- 4 ISFET chip
- 5 Seal (EPDM or perfluoro elastomer)
- 6 Sensor shaft

Weight 0.1 to 0.5 kg (0.2 to 1.1 lbs), depending on the sensor version

Material

Sensor shaft	PEEK (FDA, 3-A)
Seals	EPDM (FDA, 3-A) / Perfluoro elastomer
Diaphragm	Ceramics

Process connection Pg 13.5

Surface roughness $R_a < 0.8 \mu\text{m}$ (31.5 μin)

Temperature sensor Pt 1000 (class B acc. to DIN IEC 60751)

Plug-in head

CPS441:

- ESS; TOP68, rotatable

CPS441D:

- Memosens, rotatable

Diaphragm Ceramics, sterilizable

Ordering information

PEEK ISFET sensor for glass free pH measurement

- For blocking media
- Integrated Pt 1000 temperature sensor
- With liquid KCl electrolyte reference system and ceramics diaphragm
- Application range: pH 0 to 14, -15 to 135 °C (5 to 275 °F)
- For Ex and Non-Ex applications

Product structure CPS441

Shaft length	
2	120 mm (4.72 in)
4	225 mm (8.86 in)
5	360 mm (14.2 in)
6	425 mm (16.7 in)
Plug-in head	
ESS	Threaded plug-in head, Pg 13.5, TOP68 rotatable
Options	
1	Chip sealing: EPDM, hygienic
2	Chip sealing: Perfluoro elastomer
CPS441-	complete order code

Product structure CPS441D

Version	
7	Basic version
Shaft length	
2	120 mm (4.72 in)
4	225 mm (8.86 in)
5	360 mm (14.2 in)
6	425 mm (16.7 in)
Electrolyte supply	
A	Shaft hole for KCl refilling, CPA441
B	KCl hose connection, CPY7
Additional option	
1	EPDM, hygienic version
2	Perfluoro elastomer
Approval	
G	ATEX II 2G Ex ia IIC T3/T4/T6, FM/CSA IS/NI Cl I DIV 1&2 GP A-D
1	Non-hazardous location
CPS441D-	complete order code

Certificates and approvals

Ex approval FM/CSA

- FM
IS/NI Cl I DIV 1&2 GP A-D, associated apparatus Mycom 153-O/-P or Liquiline CM42-*P
- CSA
IS/NI Cl I DIV 1&2 GP A-D, associated apparatus Mycom 153-S or Liquiline CM42-*S

Ex approval ATEX

Device group II, Category 2G
Explosion protection Ex ia IIC T3/T4/T6

Sanitary compatibility

Cleanability validated acc. to EHEDG test criteria (TNO Report V3640 RE)

Original of report summary

"At the request of Endress+Hauser Conducta, Postfach 100154, D-70826 Gerlingen, Germany the in-place cleanability of the ISFET-Sensor Tophit CPS471 was assessed according to the test procedure of the European Hygienic Engineering & Design Group (EHEDG).

The test results show that the ISFET-Sensor Tophit CPS471, including the seals, is cleanable in-place at least as well as the reference pipe. The tests were conducted five times on one test object. The results of the tests are comparable with each other. The ISFET-Sensor Tophit CPS471 complies with the hygienic criteria of the Machinery Directive 98/37/EC, annex 1 (additional essential health and safety requirements for certain categories of machinery) section 2.1 (agri-foodstuffs machinery), the hygienic requirements of EN 1672 - part 2 and with the hygienic equipment design criteria of the EHEDG.

The test results obtained are representative of the ISFET-Sensor TopHit type CPS471 and type CPS441."

- Only sensor version with EPDM chip sealing is hygienic
- Materials in contact with medium are FDA certified
- Certified acc. to the 3-A standard no. 74-03

Accessories

Note!

In the following sections, you find the accessories available at the time of issue of this documentation.

For information on accessories that are not listed here, please contact your local service or sales representation.

Transmitters

Liquiline CM42

- Modular two-wire transmitter for Ex and non-Ex areas
- Hart®, PROFIBUS or FOUNDATION Fieldbus available
- Ordering acc. to product structure, Technical Information TI381C/07/en

Liquisys CPM223/253

- Transmitter for pH and redox, field or panel-mounted housing
- HART or PROFIBUS available
- Ordering acc. to product structure, Technical Information TI194C/07/en

Mycom CPM153

- Transmitter for pH and redox, one or two channel version, Ex or Non-Ex
 - HART or PROFIBUS available
 - Ordering acc. to product structure, Technical Information TI233C/07/en
-

Fully automatic measuring systems

Topcal CPC310

- Fully automatic measuring, cleaning and calibration system; Ex or non-Ex
- In-situ cleaning and calibration, automatic sensor monitoring
- Ordering acc. to product structure, Technical Information TI404C/07/en

Topclean CPC30

- Fully automatic measuring and cleaning system; Ex or non-Ex
 - In-situ cleaning, automatic sensor monitoring
 - Ordering acc. to product structure, see Technical Information TI235C/07/en
-

Service tool

Memocheck Plus CYP01D, Memocheck CYP02D

- Tool for the qualification of measuring chains
- Service tool for quick, on-site checks of measuring systems with Memosens technology
- Verification of data transmission
- Ordering acc. to product structure, KA399C/07/a2

Cables**CPK12 (TOP68)**

Cable length	
HA	Cable length: 5 m (16.41 ft), TPE sheath, max. 130 °C (266 °F)
HB	Cable length: 10 m (32.82 ft), TPE sheath, max. 130 °C (266 °F)
HC	Cable length: 15 m (49.23 ft), TPE sheath, max. 130 °C (266 °F)
HD	Cable length: 20 m (65.64 ft), TPE sheath, max. 130 °C (266 °F)
HF	Cable length: 5 to 20 m (16.41 to 65.64 ft), TPE sheath, max. 130 °C (266 °F)
HG	Cable length: 16 - 160 ft, TPE sheath, max. 130 °C (266 °F)
Version	
A	Standard version
Termination	
1	End sleeve on device side, braided cable screening
Potential matching	
A	External potential matching with flat plug
CPK12-	complete order code

CYK10 (Memosens)

CYK10 Memosens data cable

- For digital sensors with Memosens technology
- Ordering according to product structure, see below

Certificates	
A	Standard, non-Ex
G	ATEX II 1G Ex ia IIC T6/T4/T3, FM/CSA IS/NI Cl I DIV 1&2 GP A-D
L	LABS free, non-Ex
O	FM IS/NI Cl I DIV 1&2 GP A-D
S	CSA IS/NI Cl I DIV 1&2 GP A-D
T	TIIS
V	ATEX/NEPSI II 3G Ex nL IIC
Cable length	
03	Cable length: 3 m (9.8 ft)
05	Cable length: 5 m (16 ft)
10	Cable length: 10 m (33 ft)
15	Cable length: 15 m (49 ft)
20	Cable length: 20 m (66 ft)
25	Cable length: 25 m (82 ft)
88	... m length
89	... ft length
Ready-made	
1	Wire terminals
2	M12 plug
CYK10-	complete order code

Note!

Ex versions of CYK10 are indicated by an orange-red coupling end.

Cable extension**CYK12**

CYK12 measuring cable

- Non-terminated cable for extension of sensor cables, used in combination with CPK1, CPK9 and CPK12
- Coax and 5 pilot wires
- Sold by the meter:
 - Non-Ex version, black: order no. 51506598
 - Ex-version, blue: order no. 51506616

CYK81

CYK81 measuring cable

- Non-terminated measuring cable for extension of sensor cables of e.g. Memosens sensors, CUS31/CUS41
- 2 wires, twisted pair with shield and PVC-sheath (2 x 2 x 0.5 mm² + shield)
- Sold by the meter, order no.: 51502543

Junction boxes

Junction box VBA

- For cable extension of pH/ORP sensors
- 10 terminals, protection class: IP 65 (≅ NEMA 4X)
- Cable entries: 2 x Pg 13.5, 2 x Pg 16
- Material: polycarbonate
- Order no.: 50005276

Junction box RM

- For cable extension (e.g. for Memosens sensors or CUS31/CUS41)
- 5 terminals
- Cable entries: 2 x Pg 13.5
- Material: PC
- Ingress protection: IP 65 (≅ NEMA 4X)
- Order no.: 51500832

Junction box VBM

- For cable extension
- 10 terminals
- Cable entries: 2 x Pg 13.5 or 2 x NPT ½"
- Material: aluminum
- Ingress protection: IP 65 (≅ NEMA 4X)
- Order numbers:
 - cable entries Pg 13.5: 50003987
 - cable entries NPT ½": 51500177

United States

Endress+Hauser, Inc.
 2350 Endress Place
 Greenwood, IN 46143
 Tel. 317-535-7138
 Sales 888-ENDRESS
 888-363-7377
 Service 800-642-8737
 fax 317-535-8498
 inquiry@us.endress.com
 www.us.endress.com

Canada

Endress+Hauser Canada
 1075 Sutton Drive
 Burlington, ON L7L 5Z8
 Tel. 905-681-9292
 800-668-3199
 Fax 905-681-9444
 info@ca.endress.com
 www.ca.endress.com

Mexico

Endress+Hauser, México, S.A. de C.V.
 Fernando Montes de Oca 21 Edificio A Piso 3
 Fracc. Industrial San Nicolás
 54030. Tlalnepantla de Baz
 Estado de México
 México
 Tel: +52 55 5321 2080
 Fax +52 55 5321 2099
 eh.mexico@mx.endress.com
 www.mx.endress.com