



Level



Pressure



Flow



Temperature



Liquid  
Analysis



Registration



Systems  
Components



Services



Solutions

## Technical Information

# Orbipore CPS91 and CPS91D

pH electrodes, analog or with digital Memosens technology  
With open aperture for heavily soiled media, optional built-in  
temperature sensor



### Application

- Chemical processes
- Pulp and paper industry
- Heavily soiled media:
  - Solids
  - Emulsions
  - Precipitation

With ATEX, FM and CSA approval for application in hazardous areas

### Your benefits

- Open aperture for application in heavily soiled media
- Built-in temperature sensor for effective temperature compensation (optional)
- Low maintenance thanks to gel filling
- Long service life thanks to new stabilized gel
- Extremely insensitive to pressure and temperature variation
- Short response time
- Poison-resistant reference with ion trap (optional, CPS91D only)

### Further benefits offered by Memosens technology

- Maximum process safety through contactless inductive signal transmission
- Data safety through digital data transmission
- Easy handling thanks to storage of sensor-specific data in the sensor
- Predictive maintenance possible thanks to registration of sensor load data in the sensor

## Function and system design

### Measuring principle

#### pH measurement

The pH value is used as a unit of measurement for the acidity or alkalinity of a liquid medium. The membrane glass of the electrode supplies an electrochemical potential which is dependent upon the pH value of the medium. This potential is generated by the selective penetration of H<sup>+</sup> ions through the outer layer of the membrane. An electrochemical boundary layer with an electric potential forms at this point. An integrated Ag/AgCl reference system serves as reference electrode.

The transmitter converts the measured voltage into the corresponding pH value using the Nernst equation.

### General properties

#### ■ Open aperture

Thanks to its open aperture, the electrode is particularly suitable for application in heavily soiled media.

#### ■ Temperature compensation

Depending on the ordered version, a Pt 100, Pt 1000 or NTC temperature sensor is integrated in the electrode to measure the medium temperature.

#### ■ Durability

The electrode is pressure-proof up to 13 bar (188.5 psi) and can be applied with temperatures of up to 110 °C (230 °F).

### Important properties of CPS91D

#### Maximum process safety

The inductive and non-contacting measured value transmission of Memosens guarantees maximum process safety and offers the following benefits:

- All problems caused by moisture are eliminated.
  - The plug-in connection is free from corrosion.
  - Measured value distortion from moisture is not possible.
  - The plug-in system can even be connected under water.
- The transmitter is galvanically decoupled from the medium. The result: No more need to ask about "symmetrically high-impedance" or "unsymmetrical" (for pH/ORP measurement) or an impedance converter.
- EMC safety is guaranteed by screening measures for the digital measured value transmission.
- Application in explosion-hazardous areas is unproblematic; the integrated electronics are intrinsically safe.

#### Data safety through digital data transfer

The Memosens technology digitalizes the measured values in the sensor and transfers them to the transmitter contactlessly and free from interference potential. The result:

- An automatic error message is generated if the sensor fails or the connection between sensor and transmitter is interrupted.
- The availability of the measuring point is dramatically increased by immediate error detection.

#### Easy handling

Sensors with Memosens technology have integrated electronics that allow for saving calibration data and further information such as total hours of operation and operating hours under extreme measuring conditions. When the sensor is mounted, the calibration data are automatically transferred to the transmitter and used to calculate the current measured value. Storing the calibration data in the sensor allows for calibration away from the measuring point. The result:

- Sensors can be calibrated under optimum external conditions in the measuring lab. Wind and weather do neither affect the calibration quality nor the operator.
- The measuring point availability is dramatically increased by the quick and easy replacement of precalibrated sensors.
- The transmitter does not need to be installed close to the measuring point but can be placed in the control room.
- Maintenance intervals can be defined based on all stored sensor load and calibration data and predictive maintenance is possible.
- The sensor history can be documented on external data carriers and evaluation programs at any time. Thus, the current application of the sensors can be made to depend on their previous history.

#### Communication with the transmitter

Always connect digital sensors to a transmitter with Memosens technology. Data transmission to a transmitter for analog sensors is not possible.

**Data storage of CPS91D**

Digital sensors are able to store the following system data in the sensor.

- Manufacturing data
  - Serial number
  - Order code
  - Date of manufacture
- Calibration data
  - Calibration date
  - Calibrated slope at 25 °C (77 °F)
  - Calibrated zero point at 25 °C (77 °F)
  - Temperature offset
  - Number of calibrations
  - Serial number of the transmitter used for the last calibration
- Application data
  - Temperature application range
  - pH application range
  - Date of first commissioning
  - Maximum temperature value
  - Operating hours at temperatures above 80 °C (176 °F) and 100 °C (212 °F)
  - Operating hours at very low and very high pH values (Nernst voltage below -300 mV, above +300 mV)
  - Number of sterilizations
  - Glass membrane impedance

These system data can be displayed with Mycom S and Liquiline M transmitters.

**Measuring system**

A complete measuring system comprises:

- CPS91 pH electrode or CPS91D digital sensor
- Transmitter, e.g. Liquiline M CM42 (with Memosens technology for CPS91D)
- Special measuring cable, e.g. CPK9 or Memosens data cable CYK10 for CPS91D
- Immersion, flow or retractable assembly, e.g. Cleanfit P CPA472

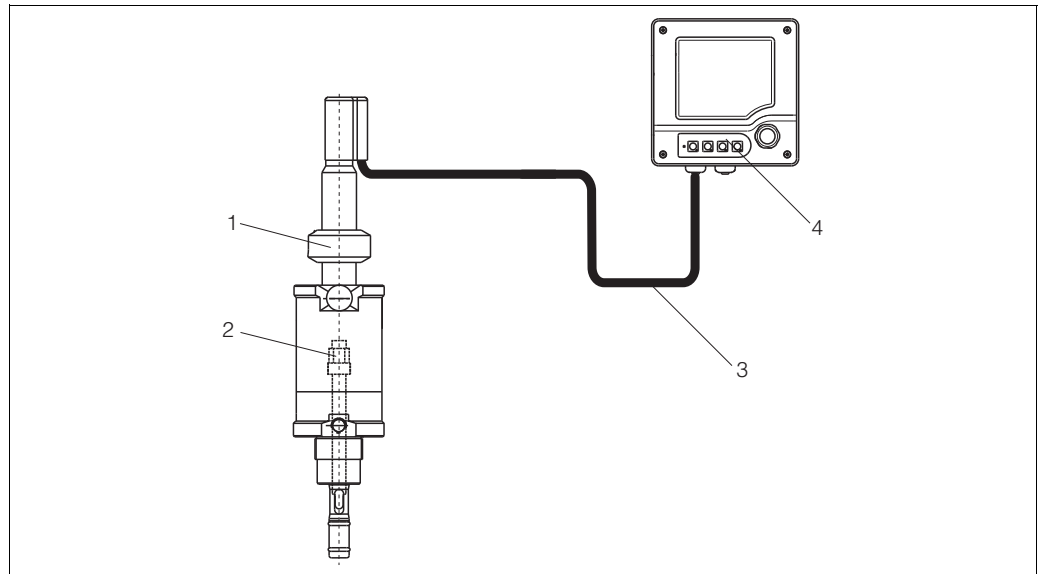

*Measuring system for pH measurement*

- 1 *Cleanfit P CPA472 retractable assembly*
- 2 *CPS91D electrode*
- 3 *CYK10 Memosens data cable for digital sensors*
- 4 *Liquiline M CM42 transmitter*

## Input

### Measured variables

pH value  
Temperature

### Measuring range

0 to 14 pH  
0 to 110 °C (32 to 230 °F)



Caution!  
Please note the process operating conditions.

## Installation

### Installation instructions

Do not install the electrode upside down. The inclination angle must be at least 15° from the horizontal. A smaller inclination angle is not permitted as such an inclination results in air cushion forming in the glass sphere. This might impair full wetting of the pH membrane with inner electrolyte.



Caution!

- Make sure that the assembly's threaded connection for the electrode is clean and well running before installing the electrode.
- Hand tighten the electrode (3 Nm)! (Given value only applies to installation in Endress+Hauser assemblies.)
- Make sure to follow the installation instructions in the operating instructions of the used assembly.

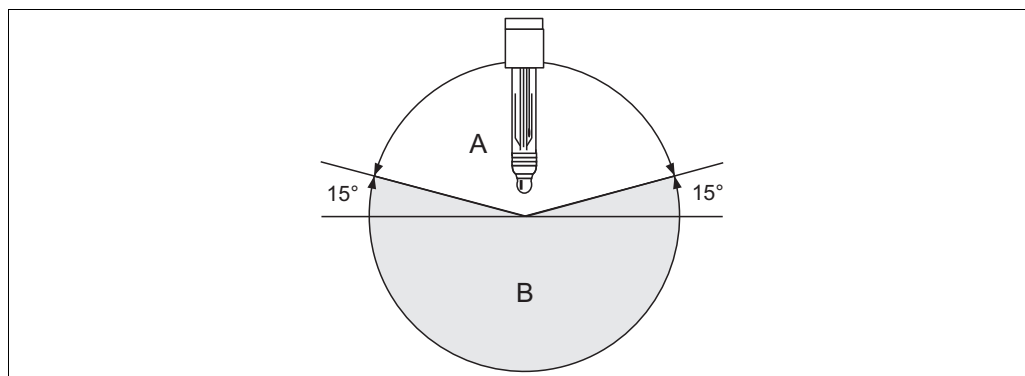

Electrode installation; inclination angle min. 15° from the horizontal

- A Permitted inclination angle  
B Non-permitted inclination angle

## Environment

### Ambient temperature



Caution!  
*Danger of frost damage*  
Do not operate the sensor at temperatures below -15 °C (5 °F).

### Storage temperature

0 to 50 °C (32 to 122 °F)

### Ingress protection

IP 67 with GSA plug-in head (with closed plug-in connection)  
IP 68 with TOP68 plug-in head (1 m (3.28 ft) water column, 50 °C (122 °F), 168 h)  
IP 68 with Memosens plug-in head (10 m (32.81 ft) water column, 25 °C (77 °F), 45 days, 1 M KCl)

## Process

**Process temperature** 0 to 110 °C (32 to 230 °F)

**Process pressure** 0 to 13 bar (0 to 188.5 psi)

**Pressure-temperature load curve**

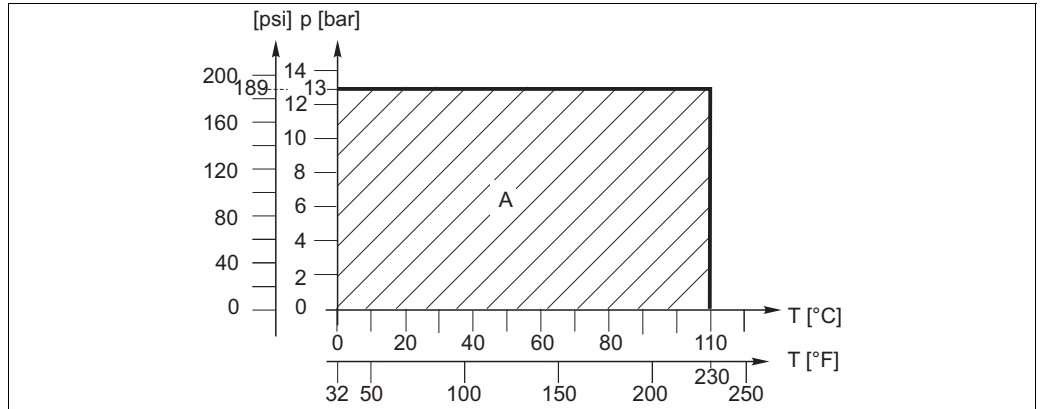

Pressure-temperature load curve

A Application range of CPS91/CPS91D

**Conductivity** min. 500  $\mu$ S/cm

**pH range**

0 to 14 pH



Caution!

Danger of damage to the electrode

Do not operate the electrode in applications outside the given specifications!

## Mechanical construction

### Design, dimensions CPS91

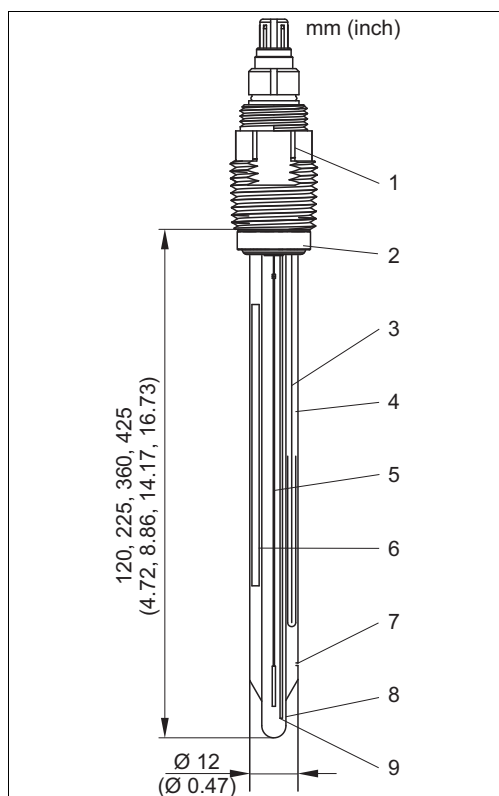

a0009216

CPS91 with ESA plug-in head, temperature sensor

- 1 TOP68 plug-in head, Pg 13.5
- 2 Viton O-ring with thrust collar
- 3 Ag/AgCl metal lead - reference chamber
- 4 Bridge electrolyte
- 5 Ag/AgCl metal lead - pH
- 6 Compensator
- 7 Open aperture
- 8 pH membrane
- 9 Temperature sensor

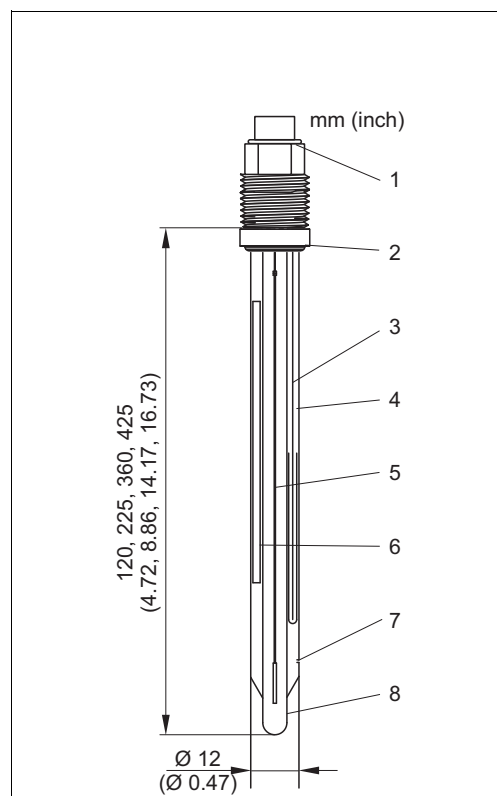

a0009217

CPS91 with GSA plug-in head

- 1 GSA plug-in head, Pg 13.5
- 2 Viton O-ring with thrust collar
- 3 Ag/AgCl metal lead - reference chamber
- 4 Bridge electrolyte
- 5 Ag/AgCl metal lead - pH
- 6 Compensator
- 7 Open aperture
- 8 pH membrane

**Design, dimensions CPS91D**

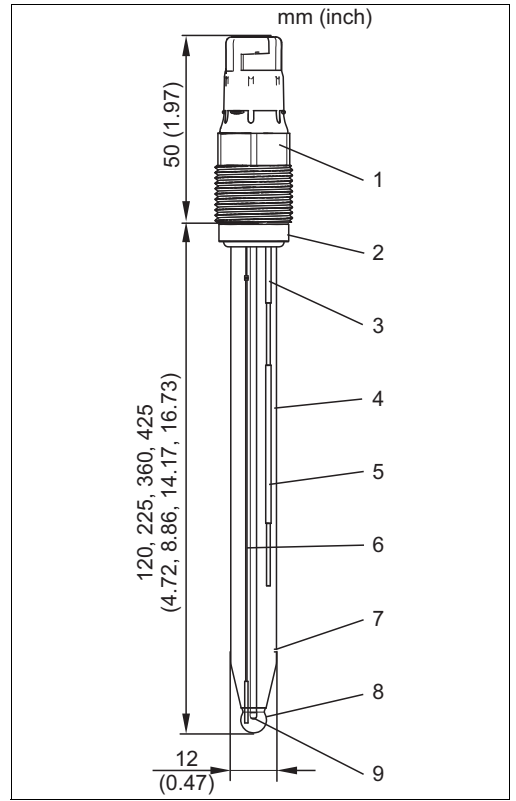
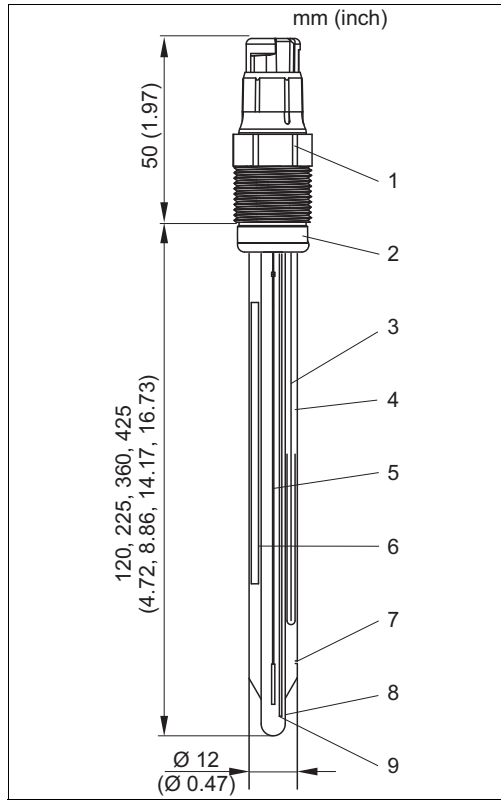

CPS91D with Memosens plug-in head, temperature sensor

CPS91D-7BTxx

- 1 Memosens plug-in head, Pg 13.5
- 2 Viton O-ring with thrust collar
- 3 Ag/AgCl metal lead - reference chamber
- 4 Bridge electrolyte
- 5 Ag/AgCl metal lead - pH
- 6 Compensator
- 7 Open aperture
- 8 pH membrane
- 9 Temperature sensor

- 1 Memosens plug-in head, Pg 13.5
- 2 Viton O-ring with thrust collar
- 3 Ag/AgCl metal lead - reference chamber
- 4 Bridge electrolyte
- 5 Ion trap
- 6 Ag/AgCl metal lead - pH
- 7 Open aperture
- 8 pH membrane
- 9 Temperature sensor

**Weight** approx. 0.1 kg (0.22 lbs)

**Materials**

Electrode shaft	glass, suitable for processes
pH membrane glass	type B
Metal lead	Ag/AgCl
Diaphragm	open aperture

**Process connection** Pg 13.5

**Temperature sensor**

CPS91:	Pt 100, Pt 1000
CPS91D:	NTC

**Plug-in heads**

CPS91:	ESA	plug-in head Pg 13.5, TOP 68 for electrodes with or without temperature sensor, 16 bar (232 psi) triple safety overpressure, Ex
	GSA	plug-in head Pg 13.5 for electrodes without temperature sensor
CPS91D:		Memosens for digital, contactless data transmission

**Reference system**

CPS91:	Ag/AgCl metal lead with reference electrolyte
CPS91D:	
Version BO	Ag/AgCl metal lead with reference electrolyte
Version BT	Ag/AgCl metal lead with ion trap

## Certificates and approvals

### Ex approval

#### CPS91 (TOP68)

- ATEX II 1G EEX ia IIC T4/T6
- FM Class I Div. 2, in combination with the Liquiline M CM42 and Mycom S CPM153 transmitters

#### CPS91D

- ATEX II 1G EEX ia IIC T4/T6
- FM / CSA Class I Div. 2, in combination with the Liquiline M CM42 and Mycom S CPM153 transmitters



#### Note!

Ex versions of digital sensors with Memosens technology are indicated by an orange-red ring in the plug-in head.

### TÜV certificate

#### TOP68 plug-in head

Pressure resistance 16 bar (232 psi), min. triple overpressure safety

#### Memosens plug-in head

Pressure resistance 16 bar (232 psi), min. triple overpressure safety

### EMC compatibility of CPS91D

Interference emission and interference immunity complies with EN 61326: 1997 / A1: 1998

## Ordering information

### Product structure CPS91

Electrode type	
1	without temperature sensor
2	with built-in Pt 100 (not available with GSA plug-in head)
3	with built-in Pt 1000 (not available with GSA plug-in head)
Application range	
BO	pH = 0 to 14, T = 0 to 110 °C (32 to 230 °F)
Shaft length	
2	120 mm (4.72")
4	225 mm (8.86")
5	360 mm (14.17")
6	425 mm (16.73")
Plug-in head	
ESA	Plug-in head Pg 13.5, TOP68, 16 bar (232 psi), Ex
GSA	Plug-in head Pg 13.5, DIN coax, non Ex
CPS91-	complete order code

### Product structure CPS91D

Version	
7	max. 110 °C (230 °F) with built-in temperature sensor
Application range	
BO	pH = 0 to 14, T = 0 to 110 °C (32 to 230 °F)
BT	pH = 0 to 14, T = 0 to 110 °C (32 to 230 °F), 13 bar (189 psi), with ion trap
Shaft length	
2	120 mm (4.72")
4	225 mm (8.86")
5	360 mm (14.17")
6	425 mm (16.73")
Options	
1	Standard
CPS91D-	complete order code



## Accessories



Note!

In the following sections, you find the accessories available at the time of issue of this documentation. For information on accessories that are not listed here, please contact your responsible service.

### Transmitters

#### Liquiline M CM42

- Modular two-wire transmitter, stainless steel or plastic, field or panel instrument,
- various Ex approvals (ATEX, FM, CSA, Nepsi, TIIS),
- HART, PROFIBUS or FOUNDATION Fieldbus available
- Ordering acc. to product structure, see Technical Information (TI381C/07/en)

#### Liquisys M CPM223/253

- Transmitter for pH and ORP, field or panel-mounted housing,
- HART or PROFIBUS available
- Ordering acc. to product structure, see Technical Information (TI194C/07/en)

#### Mycom S CPM153

- Transmitter for pH and ORP, one or two channel version, Ex or non-Ex,
- HART or PROFIBUS available
- Ordering acc. to product structure, see Technical Information (TI233C/07/en)

### Assemblies (selection)

- Cleanfit W CPA450  
Manually operated retractable assembly, for installation of 120 mm (4.72") pH/ORP electrodes in tanks and pipes;  
Ordering acc. to product structure, see Technical Information (TI183C/07/en)  
(Make sure to order the correct inner tube for your electrode version.)
- Cleanfit P CPA471  
Compact retractable stainless steel assembly, for the installation in tanks and pipes, manual or pneumatic operation;  
Ordering acc. to product structure, see Technical Information (TI217C/07/en)
- Cleanfit P CPA472  
Compact retractable plastic assembly, for the installation in tanks and pipes, manual or pneumatic operation;  
Ordering acc. to product structure, see Technical Information (TI223C/07/en)
- Cleanfit P CPA472D  
Robust retractable assembly for pH, ORP and other industry sensors, manual or pneumatic operation, heavy-duty version;  
Ordering acc. to product structure, see Technical Information (TI403C/07/en)

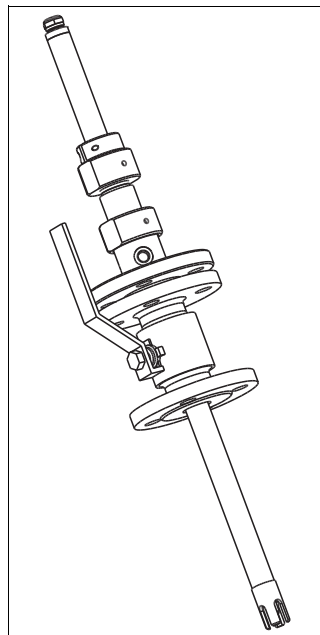

Cleanfit W CPA450

a0003135

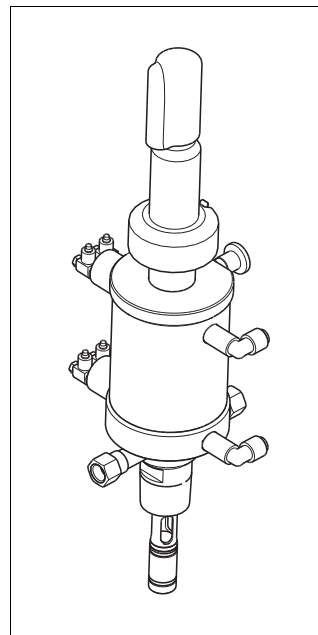

Cleanfit P CPA471 or 472

a0003137

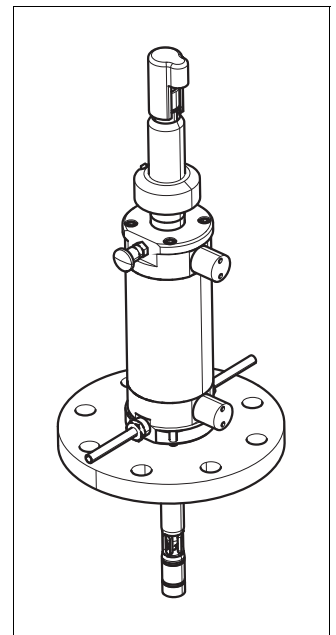

Cleanfit P CPA472D

a0009269

- Cleanfit P CPA473  
Retractable stainless steel process assembly, with ball valve for a particularly safe and reliable separation of the medium from the environment;  
Ordering acc. to product structure, see Technical Information (TI344C/07/en)
- Cleanfit P CPA474  
Retractable plastic process assembly, with ball valve for a particularly safe and reliable separation of the medium from the environment;  
Ordering acc. to product structure, see Technical Information (TI345C/07/en)
- Dipfit W CPA111  
Plastic immersion and installation assembly, for open and closed tanks;  
Ordering acc. to product structure, see Technical Information (TI112C/07/en)
- Dipfit P CPA140  
Immersion assembly for pH/ORP electrodes for demanding processes;  
Ordering acc. to product structure, see Technical Information (TI178C/07/en)

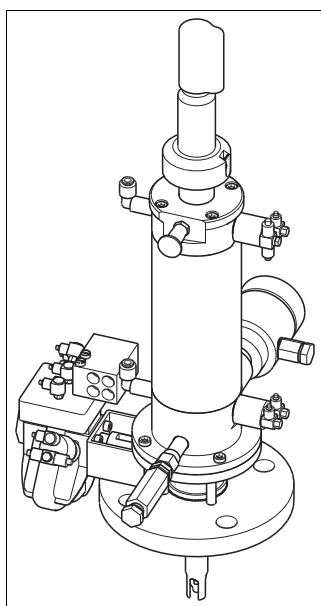
*Cleanfit P CPA473 or 474*

a0003138

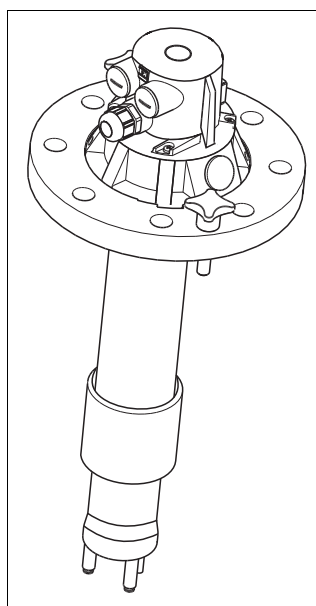
*Dipfit W CPA111*

a0003140

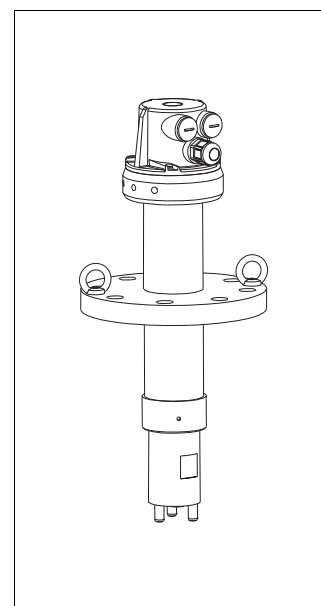
*Dipfit P CPA140*

a0003141

- **Flowfit P CPA240**  
Flow assembly for pH/ORP, for demanding processes;  
Ordering acc. to product structure, see Technical Information (TI179C/07/en)
- **Flowfit W CPA250**  
Flow assembly for pH and ORP measurement  
Ordering acc. to product structure, see Technical Information (TI041C/07/en)
- **Ecofit CPA640**  
Process connection adapter and cable set for 120 mm (4.72") pH/ORP electrodes with TOP68 plug-in head;  
Ordering acc. to product structure, see Technical Information (TI264C/07/en)

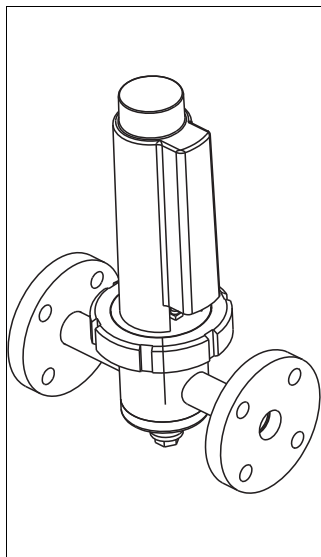

Flowfit P CPA240

a0003142

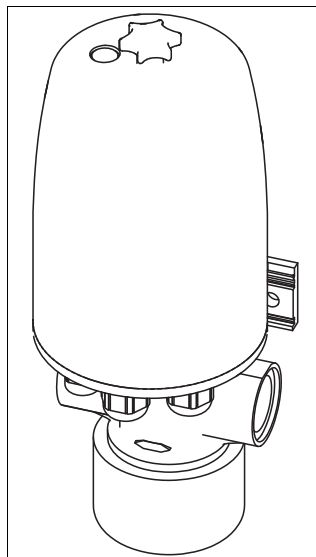

Flowfit W CPA250

a0003143

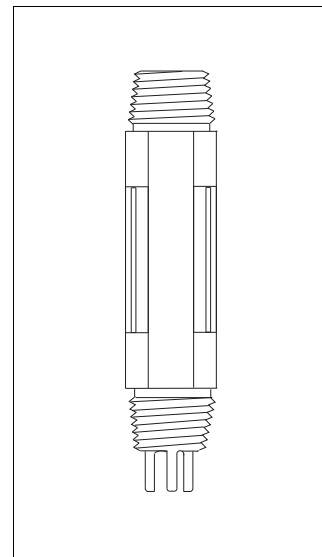

Ecofit CPA640

a0003145

**Buffer solutions**

**High-quality buffer solutions of Endress+Hauser**

The secondary buffer solutions have been referenced to primary reference material of the PTB (German Federal Physico-technical Institute) and to standard reference material of NIST (National Institute of Standards and Technology) according to DIN 19266 by a DKD (German Calibration Service) accredited laboratory.

pH value	
A	pH 2.00 (accuracy ± 0.02 pH)
C	pH 4.00 (accuracy ± 0.02 pH)
E	pH 7.00 (accuracy ± 0.02 pH)
G	pH 9.00 (accuracy ± 0.02 pH)
I	pH 9.20 (accuracy ± 0.02 pH)
K	pH 10.00 (accuracy ± 0.05 pH)
M	pH 12.00 (accuracy ± 0.05 pH)
Quantity	
01	20 x 18 ml (0.68 fl.oz) only buffer solutions pH 4.00 and 7.00
02	250 ml (8.45 fl.oz)
10	1000 ml (0.26 US gal)
50	5000 ml (1.32 US gal) canister for Topcal S
Certificates	
A	Buffer analysis certificate
Version	
1	Standard
CPY20-	complete order code

## Measuring cables

CPK9 special measuring cable

- For sensors with TOP68 plug-in head, for high-temperature and high-pressure applications, IP 68
- Ordering acc. to product structure, see Technical Information (TI118C/07/en)

CPK1 special measuring cable

- For pH/ORP electrodes with GSA plug-in head
- Ordering acc. to product structure, see Technical Information (TI118C/07/en)

CPK12 special measuring cable

- For pH/ORP glass electrodes and ISFET sensors with TOP68 plug-in head
- Ordering acc. to product structure, see Technical Information (TI118C/07/en)

CYK10 Memosens data cable

- For digital sensors with Memosens technology
- Ordering according to product structure, see below

Certificates	
A	Standard, non Ex
G	ATEX II 1G EEx ia IIC T6/T4
Cable length	
03	Cable length: 3 m (9.8 ft)
05	Cable length: 5 m (16 ft)
10	Cable length: 10 m (33 ft)
15	Cable length: 15 m (49 ft)
20	Cable length: 20 m (66 ft)
25	Cable length: 25 m (82 ft)
88	... m length
89	... ft length
Ready-made	
1	Wire terminals
CYK10-	complete order code

## Instruments International

Endress+Hauser  
Instruments International AG  
Kaegenstrasse 2  
4153 Reinach  
Switzerland

Tel.+41 61 715 81 00  
Fax+41 61 715 25 00  
www.endress.com  
info@ii.endress.com

**Endress+Hauser** 

People for Process Automation