



Level



Pressure



Flow



Temperature

Liquid
Analysis

Registration

Systems
Components

Services



Solutions

Technical Information

STIP-scan CAM74/CAS74

Measuring system for online measurement of nitrate, COD_{eq} , BOD_{eq} , TOC_{eq} , SAC, total solids, sludge volume, sludge index and turbidity



Application

STIP-scan is an in-situ measuring system for the following applications:

- Continuous monitoring of organic contamination and/or nitrate in water and waste water
- Monitoring of industrial wastewater with application specific calibration curves
- Special measurements in the spectral range from 200 to 680 nm
- Measurement of sludge parameters

Your benefits

- Measurement directly in the process
- Minimum operational costs
 - No chemicals required
 - No external sampler and sample conditioning
 - Self-cleaning and low maintenance
- Measuring cycle 2 minutes and higher
- Wavelengths can be adjusted as required for SAC and turbidity
- Patented, fully automated contamination detection
- Optional:
 - Internal calibration system allows automatic calibration and adjustment without reference solution
 - Calibration standards for high concentration, medium concentration and zero point calibration
 - Connection via Modbus RTU or via PROFIBUS-DP

Function and system design

Measuring principle

Spectral measuring

Inside the sensor a xenon flash light beams light in the range of ultraviolet to visible through the medium. A mirror guides the passing light to the spectrometer. The spectrometer measures the spectral distribution of the light intensity. The intensities are used to calculate the concentration of the absorbing substance.

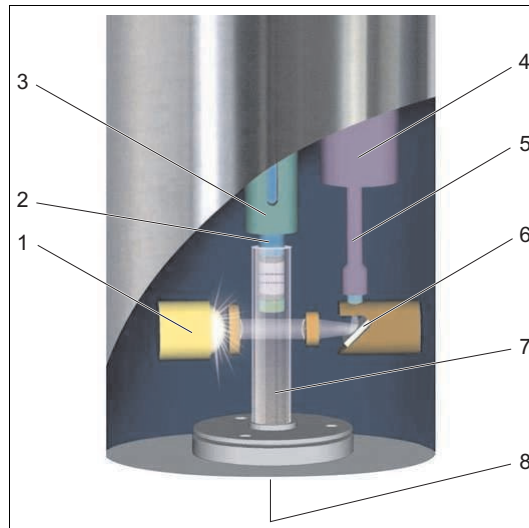

- 1 Xenon flash lamp
- 2 Piston with seal ring and optional calibration filters
- 3 Guide tube
- 4 Spectrometer
- 5 Fiber optics cable
- 6 Mirror
- 7 Quartz tube (settling and measuring cell)
- 8 Sample inlet

Optical base and guide tube

a0007124

Transmitter

The transmitter

- controls the connected sensors (max. two),
- analyzes the measurement results and
- provides operator guidance.

The transmitter is available in two versions:

- in a stainless steel weather protection housing or
- in a aluminum version

The transmitter consists of:

- an IPC-PC with touch screen (stainless steel) or a MAT-PC with touch screen (aluminum)
- power supplies
- RS232/RS485 converter module (per sensor)

and optionally:

- two or four current outputs (per sensor)
- relay module with seven normally open contacts (per sensor)
- PROFIBUS DP module or Modbus RTU module
- internal calibration system (version SC)



a0011518

Transmitter CAM74 in weather protection housing (stainless steel version)



a0011450

Transmitter CAM74 (aluminum version) with weather protection roof

Measuring system

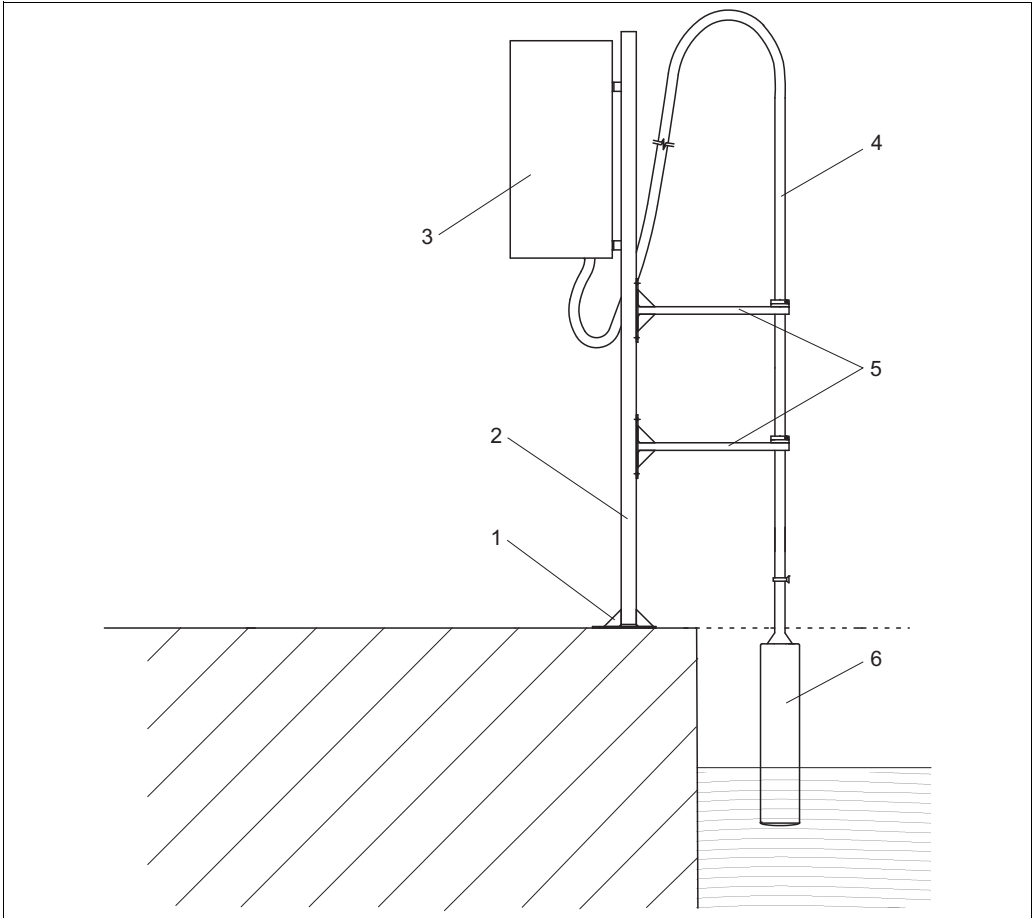

STIP-scan measuring point with stand

40007131

- 1 Base plate
- 2 Stand
- 3 Transmitter CAM74 in weather protection housing
- 4 Connecting cable with supporting pipe
- 5 Supporting arms
- 6 STIP-scan sensor CAS74

Input

Measuring range

Parameter	Measuring range
NO ₃ -N	0.3 to 23 mg/l
COD equivalent	10 to 2000 mg/l ¹⁾
BOD equivalent	10 to 2000 mg/l ¹⁾
TOC equivalent	4 to 800 mg/l ¹⁾
SAK ₂₅₄	1 to 250 m ⁻¹
Sludge-TS	0.5 to 5.0 g/l
SV	100 to 900 ml/l ²⁾
SI	SI = SV divided by Sludge-TS
ATU	1 to 200 m ⁻¹

1) based on potassium hydrogen phthalate

2) undiluted sample

Wavelength 200 to 680 nm

Cable specification max. 20 m (65.6 ft.)

Output

Current range 0/4 to 20 mA

Accuracy ±0.1 % of end of measuring range

Load max. 500 Ω

Resolution ±0.02 % of end of measuring range

Isolation max. 3000 V DC

Relays

Number	7 normally open contacts
Contact rating	0.5 A at 120 V AC / 1.0 A at 24 V DC

PROFIBUS

Type	PROFIBUS DP Slave
Protocol	DP-V0 or DP-V1 (class 1/2)
I/O memory	368 byte

Modbus

Type	RTU
------	-----

Power supply

Electrical connection of the transmitter

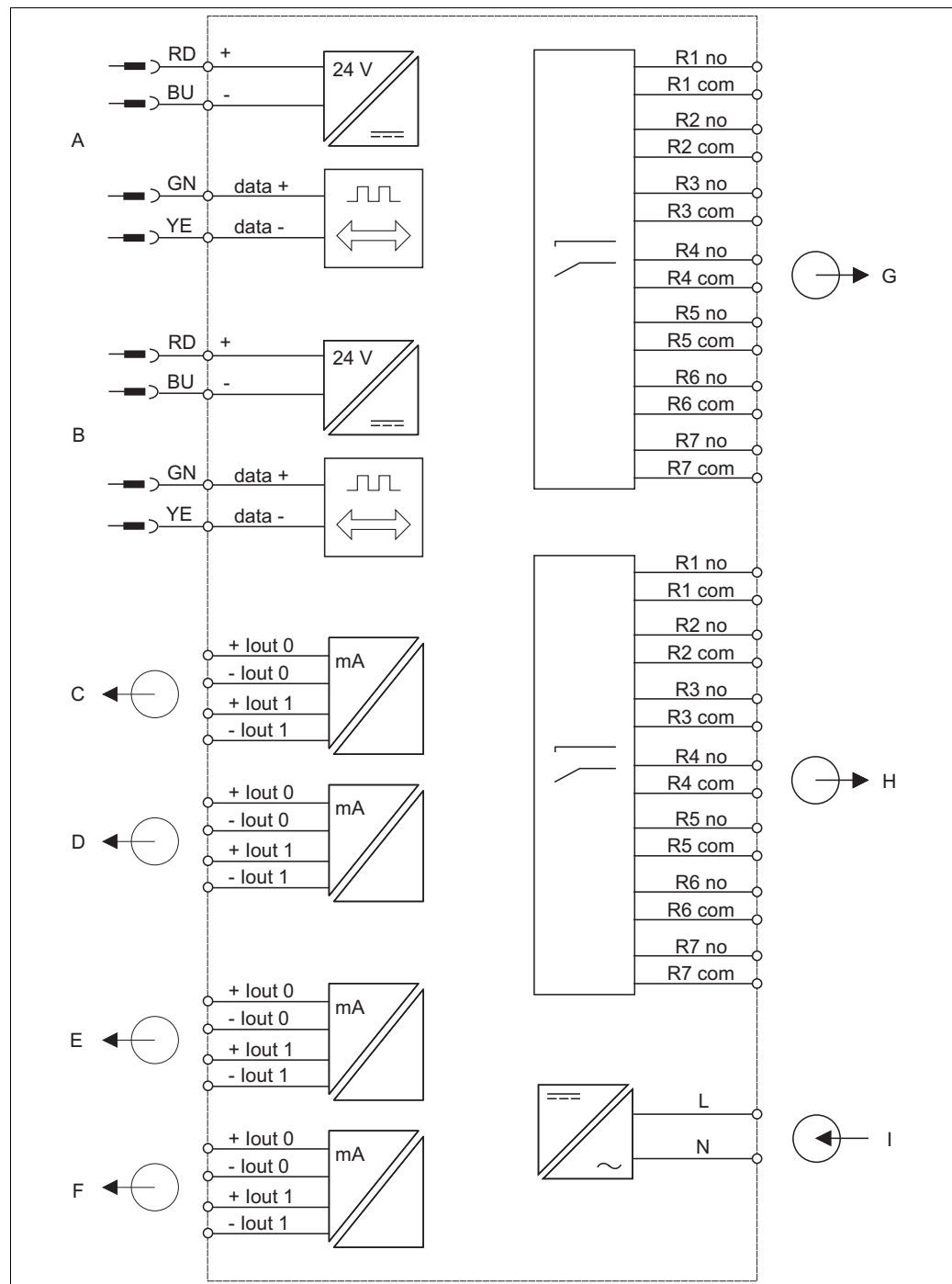

Electrical connection of the transmitter (stainless steel and aluminum version)

A	Sensor 1	F	Signal output 2 sensor 2
B	Sensor 2	G	Relays 1 to 7 sensor 1
C	Signal output 1 sensor 1	H	Relays 1 to 7 sensor 2
D	Signal output 2 sensor 1	I	Power supply
E	Signal output 1 sensor 2		

Supply voltage 115/230 V 50/60 Hz (stainless steel version)
100 to 250 V 50 to 60 Hz (aluminum version)

Power consumption approx. 130 VA

Performance characteristics

Measured value resolution	NO ₃ -N	0.1 mg/l
	COD equivalent	2 mg/l
	BOD equivalent	2 mg/l
	TOC equivalent	1 mg/l
	SAC ₂₅₄	0.1 m ⁻¹
Sample rate	Inlet and outlet	2 to 60 min
	Activated sludge basin	depends on the sludge composition
Repeatability	max. 3 % of end of measuring range for parameters NO ₃ -N, COD, BOD, TOC, SAC	
Response time	120 s (depending on application; longer intervals selectable)	

Installation conditions

Installation conditions

Note!

Install the sensor at a stand with supporting arms or at a wall bracket with supporting arms. Do not install the sensor suspended from the connection cable!

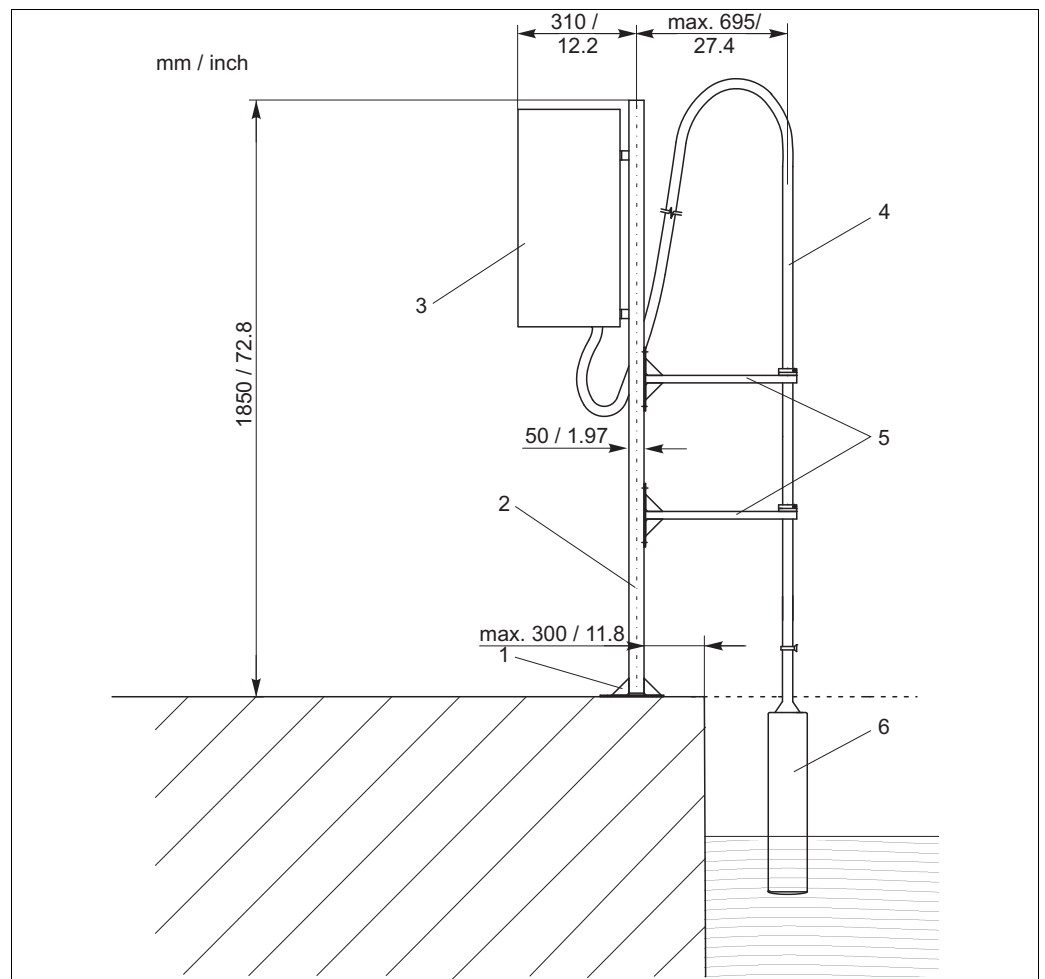

Stand with supporting arms

- 1 Base plate
- 2 Stand
- 3 Transmitter CAM74 in weather protection housing
- 4 Connection cable with supporting pipe
- 5 Supporting arms
- 6 STIP-scan sensor CAS74

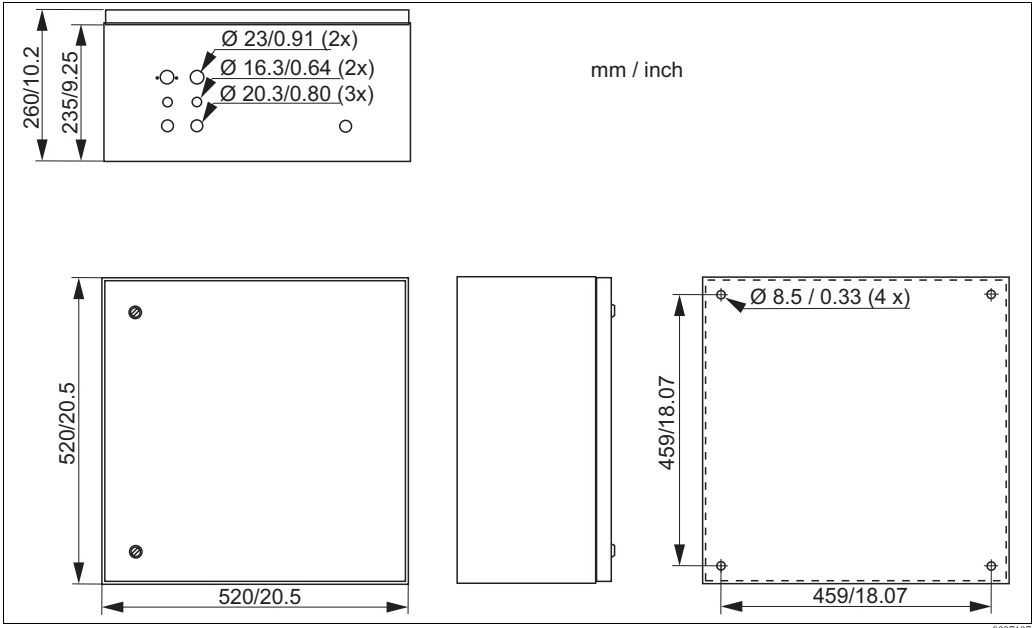

Weather protection housing CAM74 (stainless steel version)

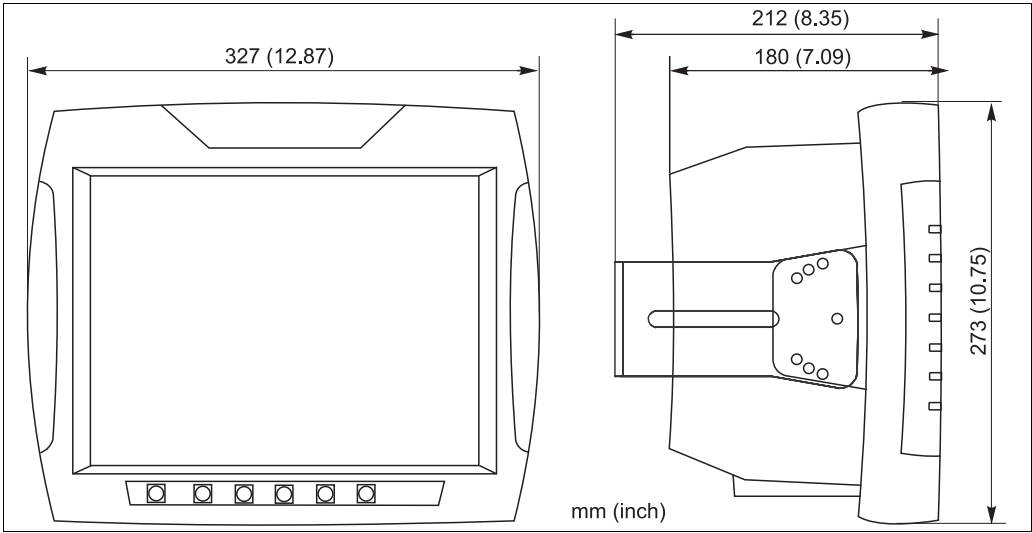

Transmitter CAM74 (aluminum version)

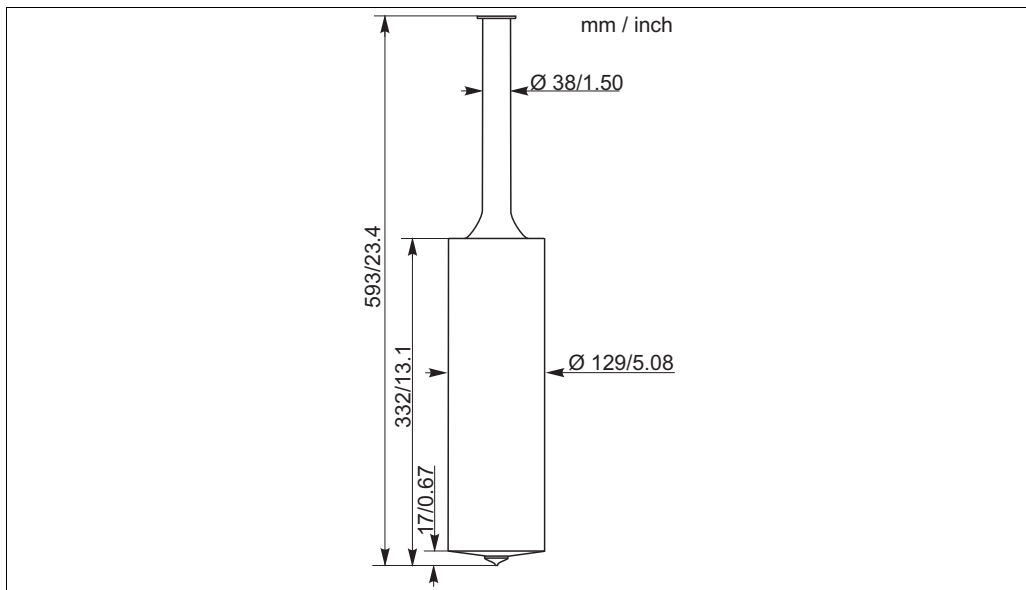

Sensor CAS74

a0007196

Environment

Ambient temperature	-10 to +40 °C (+14 to 104 °F) (transmitter in closed weather protection housing)	
Ingress protection	Sensor (closed housing)	IP67
	Transmitter as stainless steel version (front side closed)	IP65
	Transmitter as stainless steel version (front side open)	IP55
	Transmitter as aluminum version	IP65
Electromagnetic compatibility	Interference emission and interference immunity of the complete measuring system comply with EN 61326.	
Safety regulations	Complies with safety requirements according to EN 61010.	

Process

Process temperature range	0 to 30 °C (32 to 86 °F) For medium temperatures > 30 °C (> 86 °F) a separate applications test is required!	
Process pressure	0 to 0.3 bar (4.4 psi)	
Immersion depth	max. 550 mm (21.7")	
Particle size	< 1 mm	
Suspended solids	< 5 g/l (< 5000 ppm)	
Sludge volume	max. 750 ml/l for undiluted sample after 30 min	

Mechanical construction

Dimensions	Transmitter (stainless steel version)	W x H x D: 520 x 520 x 260 mm (20.5" x 20.5" x 10.2")
	Transmitter (aluminum version)	W x H x D: 327 x 273 x 180 mm (12.87" x 10.75" x 7.09")
	Sensor	L = approx. 600 mm (23.6"); Ø = 129 mm (5.08")
Weight	Transmitter (stainless steel version)	approx. 31 kg (68 lbs)
	Transmitter (aluminum version)	approx. 7.7 kg (17 lbs)
	Sensor	approx. 8.3 kg (18.3 lbs)
Materials	Transmitter (stainless steel version)	stainless steel 1.4301 (AISI 304)
	Transmitter (aluminum version)	aluminum casting
	Sensor (body)	stainless steel 1.4571 (AISI 316 Ti)
	Sensor holder	stainless steel 1.4571 (AISI 316 Ti)

Human interface

Display and operating elements

The transmitter is operated via the integrated touch screen.



Display and operating elements (stainless steel version)

a0011450



Display and operating elements (aluminum version)

a0011450

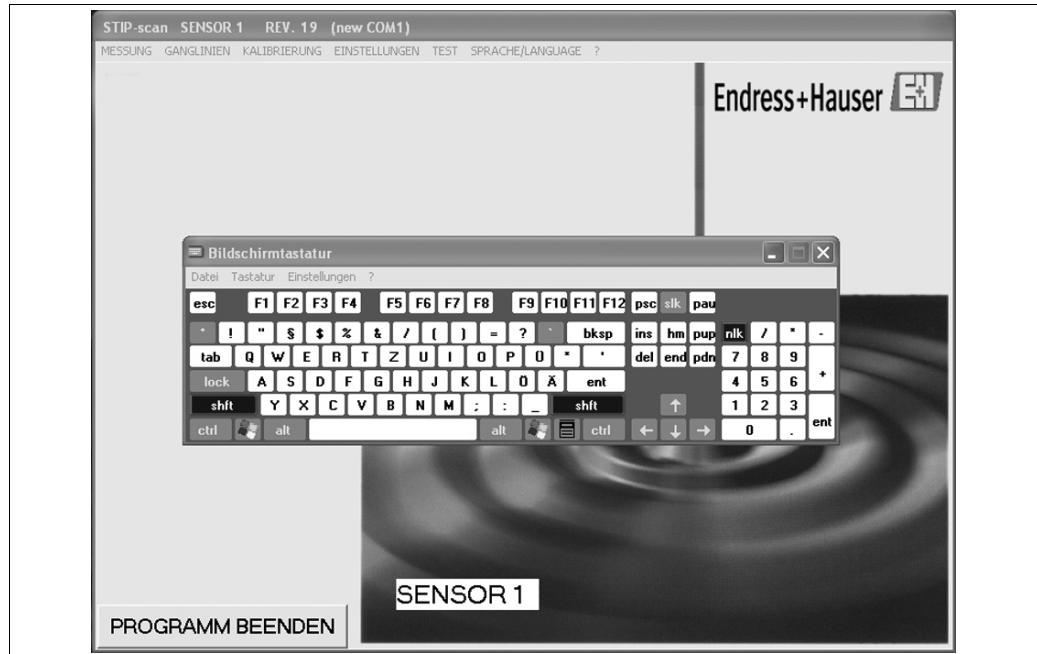

Touch screen keyboard

Monitor	12 " TFT color display; 800 x 600 pixels
Operating system	Windows XP
Interfaces	3 x USB, 2 x COM, 1 x LAN 10/100 MBit, PS2 keyboard connection, internal PC-104 slot

Certificates and approvals

CE symbol

Declaration of conformity

The product meets the requirements of the harmonized European standards. It thus complies with the legal requirements of the EC directives.

The manufacturer confirms successful testing of the product by affixing the CE symbol.

Ordering information

Order code

You can create a valid and complete order code with the configurator on the internet.

To get to the product page enter the following address into your browser:
www.products.endress.com/cam74 for the transmitter or
www.products.endress.com/cas74 for the sensor

1. On the right hand side of the product page you will find the following menu items:

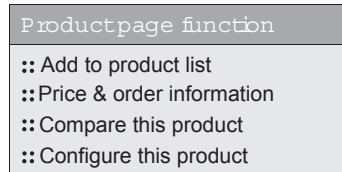

2. Click on "Configure this product".
 3. The configurator appears in a new window. Now you can configure your device and you will get the corresponding order code.
 4. At the top of the page you can export the order code as PDF file or as Excel file.
-

Scope of delivery

The following are included in the scope of supply of the measuring system:

- Sensor holder
- Sensor
- Data cable
- Transmitter
- Air pump
- Operating Instructions

Accessories

Installation accessories

Supporting arms

- complete set 700 mm; supplement to 71013968; stainless steel 1.4301 (AISI 304)
- order no. 71013964

Wall mounting for transmitter and one sensor

- stainless steel 1.4301 (AISI 304)
- order no. 71013961

Mounting material

- mounting material for wall mounting of the transmitter (stainless steel version)
- order no. 71013971

Stand and mounting material for transmitter and one sensor

- stainless steel 1.4301 (AISI 304)
- order no. 71013970

Stand and mounting material for one sensor

- for second measuring position; stainless steel 1.4301 (AISI 304)
- order no. 71013968

Flow through assembly

- for bypass applications with open drain
- material: stainless steel 1.4571 (AISI 316 Ti)
- order no. 71013995

Sample reservoir chamber

- dimensions: 540 x 500 x 300 mm (21.3" x 19.7" x 11.8")
- for 1 or 2 sensors
- material: stainless steel 1.4571 (AISI 316 Ti)
- order no. 71013929

Weather protection roof for aluminum version of CAM74

- mandatory for outside use
- dimensions: 370 x 470 x 455 mm (14.6" x 18.5" x 17.9")
- material: polycarbonat (PC)
- order no. 71092182

Instruments International

Endress+Hauser
Instruments International AG
Kaegenstrasse 2
4153 Reinach
Switzerland

Tel.+41 61 715 81 00
Fax+41 61 715 25 00
www.endress.com
info@ii.endress.com

Endress+Hauser 
People for Process Automation