

Process and Flow Assemblies for Turbidity Measurement *CUA 120 / FlowFit W CUA 250*

Adapter for flow assembly and flange mounting,
optionally available with spray function



Continuous in-line measurement of turbidity in aqueous media is used for real-time measurement of non-soluble substances in water for purposes of monitoring, detection of operating states and control applications.

Areas of application

- Discharge monitoring in communal and industrial waste water
- Sedimentation monitoring in waste water treatment (coagulation and flocculation)
- Recycling of industrial service water
- Filter effluent and filter rupture monitoring
- Clear rinse cycle monitoring
- Flotation process monitoring
- Monitoring of closed circuits, e.g. cooling water, product pipelines

Benefits at a glance

- Flow assemblies featuring simple adaptation to standard piping
- Excellent handling properties
- Optimized fluidic design prevents sedimentation
- Sensor orientation can be adapted to individual requirements of application
- Self-cleaning effect due to medium flow against sensor and rejection of water bubbles
- Additional cleaning device employs spray cleaning to increase sensor maintenance intervals
- Robust, compact design
- Flange adapter for standardized DN 50 flange installation

Pipeline

Recommended mounting positions of CUS with CUA 120-A/-B adapter or CUA 461 retractable assembly

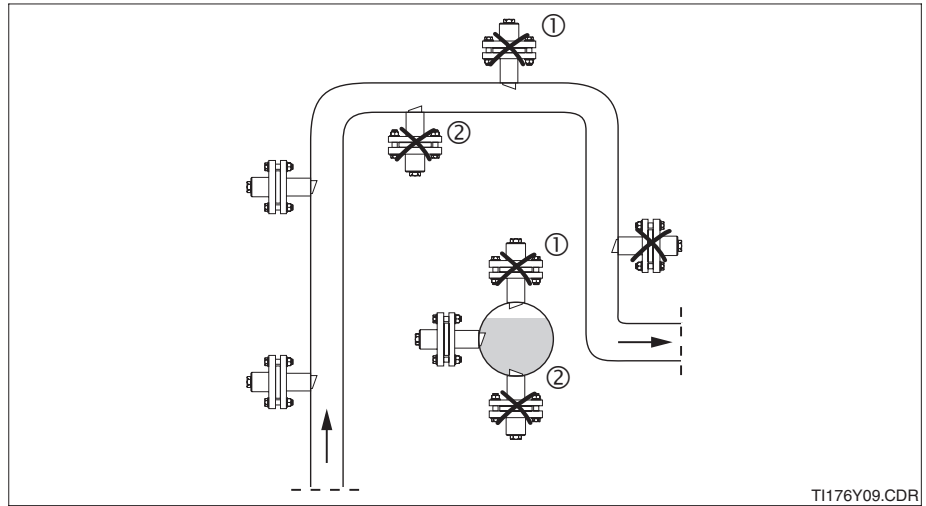

TI176Y09.CDR

Notes for installation

- The pipe diameter must be at least DN 100 when bright materials (VA or the like) are used.
- Install the sensor in places with constant flow conditions. Do not install it in places where air may collect, where foam bubbles are likely to form (①) or where suspended solids may settle (②).
- Orient the sensor surface against the medium flow.
- Suitable for CUS 1*, CUS 4*, CUS 5, CUS 31, CUS 41
* (version only without wiper)

Mounting

- Lead connection cable through sleeve and hexagon coupling without twisting it.
- Insert sensor body into the sleeve so that the O-ring adjoins under G 1" screw thread in the sleeve. Note marking pin and marking hole on the sleeve.
- Install CUS sensor into the adapter in such a way that the acute-angled edge of the sensor lies opposite the marking hole and points away from it. The marking hole renders the sensor orientation clearly identifiable.

left:
CUA 120-B adapter with welding socket DN 50 / ANSI 2" (s.b. / accessory) and loose flange DN 50 / ANSI 2" (to be provided by customer)

right:
120-A adapter
1 Weld-on flange
2 Seal
3 Loose flange
4 Bolted flange joint
5 Sleeve
6 Marking hole
7 Hexagon gland
8 Connecting cable (1-4 to be provided by customer)

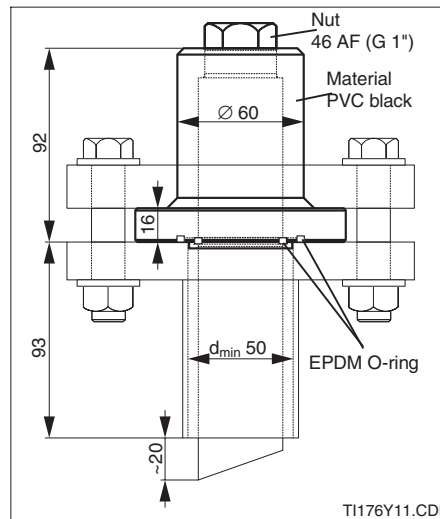

TI176Y11.CDR

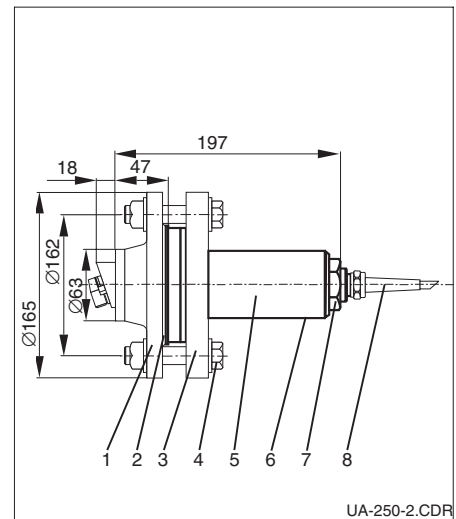

UA-250-2.CDR

Welding socket DN 50 / ANSI 2"	
Material	Order no.
Stainless steel 1.4571	50080249
Polyvinyl chloride PVC	50080250
Polypropylene PP	50080251

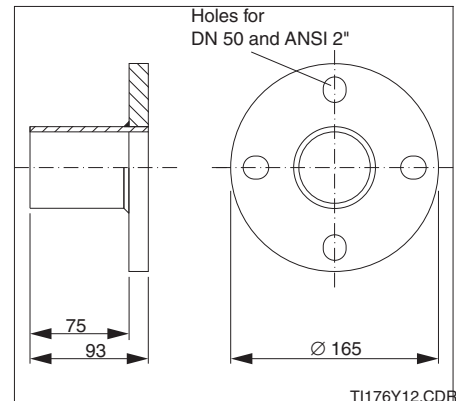

TI176Y12.CDR

right:
Welding socket for pipe diameter greater than 80 mm

Installation in flow assemblies

Notes on installation

- The medium should, if possible, flow into the assembly from below. If the flow assembly must be installed in a horizontal instead of a vertical position, then orient the sensor in the 3 o'clock or 9 o'clock position. This helps avoid air pockets.
- Sensor orientation parallel to the medium flow is necessary:
 - for turbidities < 5 FNU, to minimise wall reflection effects. Also carry out installation adjustment¹
 - in conjunction with the spray head CUR 3.
- Sensor orientation against the medium flow is used to increase self-cleaning effects:
 - in heavily soiled media with turbidities > 15 FNU, where wall reflections can in any case be neglected due to the high absorption rate.

Sensor orientation parallel to the medium flow

The sensor is inserted into the union nut. Loosely tighten the hexagon coupling on the G 1" thread of the sensor. When the sensor is inserted with the sleeve on, the fitting hole on the upper edge of the assembly accommodates the locking pin. Position the sensor by turning it in such a way that the sharp edge formed by inclined sensor surface and sensor cylinder lies opposite the marking pin and points away from it. The spray-head connection in the T-section of the CUA 250 is now located over the sensor surface.

Sensor orientation against the medium flow

Position the sensor by turning it until the sharp edge formed by inclined sensor surface and sensor cylinder lies turned by 90° opposite the marking pin and points in the flow direction of the medium. Hand-tighten the hexagon nut.

left:
Orientation parallel to the medium flow
right:
Orientation against the medium flow

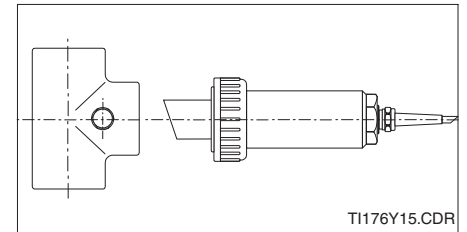
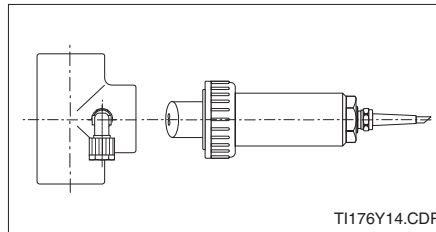

CUA 250-A, CUA 250-B with CUR 3-1 spray head

- Screw the CUR 3-1 spray head into the CUA 250 assembly in place of the lateral plug screw.
- Mount the CUS 31 sensor as above with parallel sensor orientation to ensure optimum self-cleaning effect.

Dimensions
left:
CUA 250-A/-B

right:
CUA 250-A/-B with
CUR 3-1 spray head

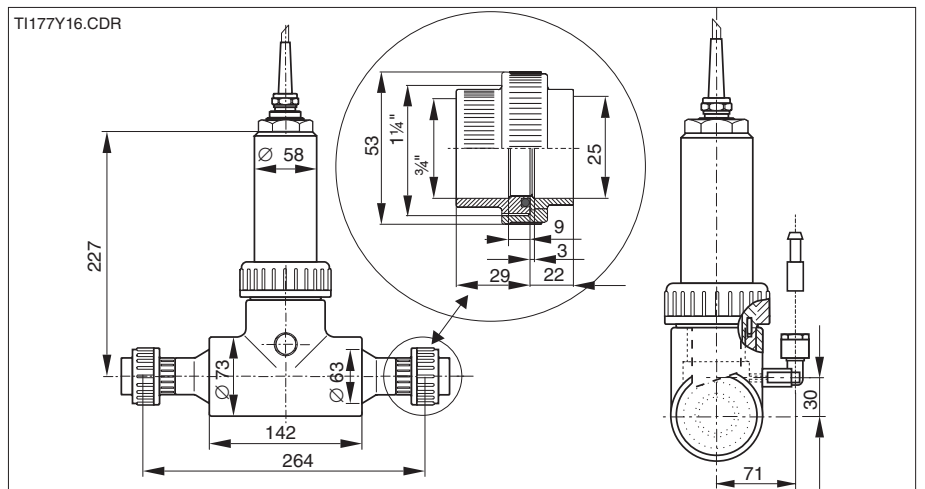

Technical Data

General data

Manufacturer	Endress+Hauser Conducta GmbH+Co.
Product designation	CUA 120 or FlowFit W CUA 250

Temperature / pressure

Specification	25 °C / 6 bar, 50 °C / 3 bar, 60 °C / 1 bar
Nominal operating range	10 ... +55 °C
Limit operating range	10 ... +60 °C
Storage temperature range	20 ... +65 °C

Materials

Materials CUA 120	PVC, stainless steel 1.4571
Materials CUA 250	PVC
O-ring seals	EPDM

How to order

Flange installation adapter CUA 120

DN flange installation adapter for turbidity sensors CUS

Materials / seals

- A Adapter for welding flange (flange height h=47 mm)
- B Installation adapter (adapter height=93 mm)
- Y Special version

CUA 120- ← complete order code

Flow assembly FlowFit W CUA 250

Flow assembly for turbidity sensors CUS

Connection

- A Installation with screw connections DN 25
- B Installation in pipe sections DN 63
- Y Special version

CUA 250- ← complete order code

Chemoclean CUR 3

Spray head for CUA 250

Materials / seals

- 1 EPDM / PVC, PVDF
- 9 Special version

CUR 3 ← complete order code

Accessories

- CUY 2 spare part kit for turbidity assemblies (connection to tubing or hose)
- CYR 10 cleaning injector with valves for drive water and cleaning agent

Endress+Hauser GmbH+Co.
- Instruments International -

P.O. Box 2222
D-79574 Weil am Rhein
Tel. (07621) 975 - 02
Fax (07621) 975345

Endress + Hauser
Nothing beats know-how

