

# EE46

# Condensation Monitor

EE46 condensation monitors are used to monitor the formation of condensation on chilled ceilings or to prevent condensation at critical spots of heating-, ventilation- and air conditioning systems. It is also used as a dew point monitor for systems operating near the dewpoint.

Because of the temperature coupling between the condensation monitor and the environment, the relative humidity is a measure for the dew point. The condensation monitor measures the relative humidity near the dew point using its high-quality capacitive sensor. At reaching the switching point of 90% RH the output will provide an early warning signal for the initiation of control steps (increasing the initial water temperature, reducing the cooling capacity, switching on the heating, etc...). An additional status light indicates the condensation danger.

Thanks to the special protection coating, sensor and electronics are highly insensitive to dust and dirt. EE46 condensation monitors can be mounted on walls, ducts and pipes up to 2".



EE46

## Typical Applications

chilled ceilings  
 heating-, ventilation- and  
 air conditioning systems  
 switching cabinets

## Features

early detection of condensation danger  
 compact design  
 fast response time  
 dust protection  
 simple and easy mounting  
 status indication

## Technical Data

Humidity sensor	HC105
Working range	10...100% RH
Switching point at 20°C (68°F)	90±3% RH
Switching hysteresis	
Response time at change of pipe/wall temperature	$t_{90} < 3 \text{ min.}$
Response time at change of relative humidity	$t_{90} < 25 \text{ sec.}$
Electrical output	potentialfree relay with changeover contact
Switching capacity	max. 24V AC/DC, 1A
Supply voltage	24V AC/DC ±20%
Current consumption at 24V DC	< 3mA
Relay status indication	LED, red
Electrical connection	5-pole push-in terminal, max. 1.5 mm <sup>2</sup> (AWG 16)
Dust protection	by special coating (permeable for water vapour)
Housing protection class	IP40
Housing material	Polycarbonate, UL94-V2 approved
Electromagnetic compatibility	EN 61326-1 EN 61326-2-3 industrial environment
Temperature range	working temperature range 0...50°C (32...122°F) storage temperature range -20...70°C (-4...158°F)
Weight	approx. 60g



## Dimensions (mm)

1 mm = 0.03937" / 1" = 25.4 mm

## Installation

### Pipe mounting

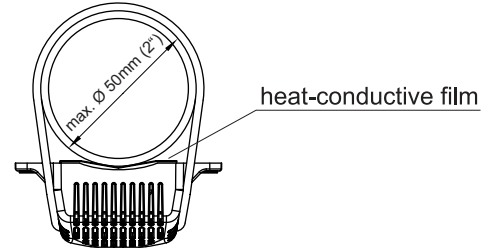
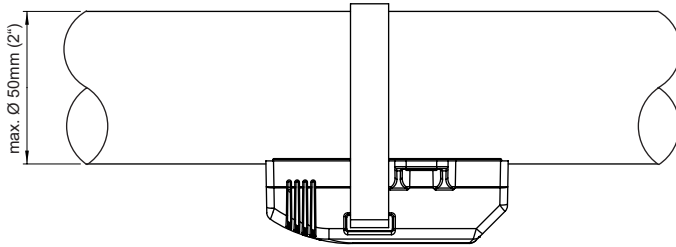

### Wall mounting

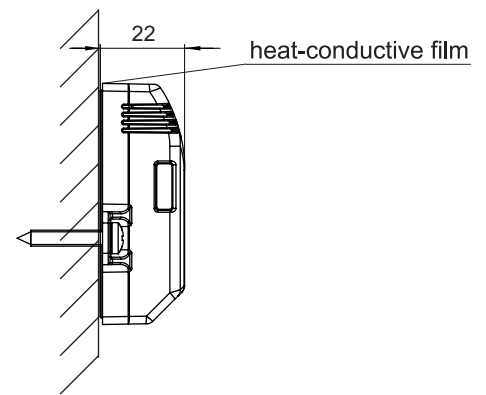
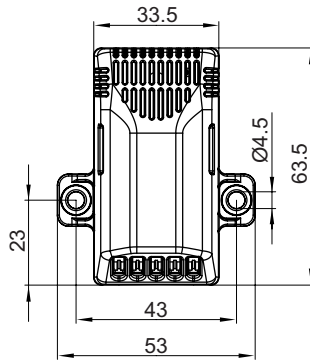

## Connection Diagram

## Status Indication

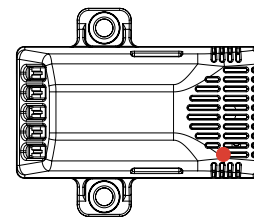
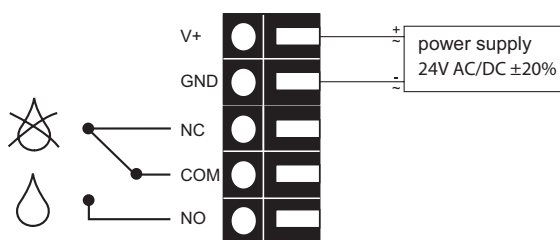

- LED continuous red: Operating < 90% RH
- LED blinking red: Condensation danger

## Ordering Guide

Condensation Monitor EE46

(EE46)