

EE576 Series

Miniature Air Velocity Transmitter for Measurement of Lowest Velocity

The EE576 is a compact air velocity transmitter designed for measurement of lowest velocity. Equipped with a newly developed sensor head and utilizing the proven E+E hot-film element, already tested a million times in the automotive industry, these transmitters are less sensitive to dust and dirt than conventional hot-wire elements. This is reflected in the excellent reproducibility and proven long-term stability of the measuring results.

The factory calibration with a special wind tunnel for lowest velocity ensures optimal precision and maximum sensitivity.

The EE576 can be mounted fast and easily.

The alignment strip along the probe's tube and the matching mounting flange determine the orientation of the sensor probe. The mounting flange allows for an infinitely variation of the depth of the sensor probe.

The electronics integrated in the probe tube provide a linear analogue signal of 0-5V or 0-10V for the velocity range 0...1m/s (0...200ft/min) or 0...2m/s (0...400ft/min).



EE576

Typical Applications

laminar flow control
 filter monitoring
 exhaust systems
 glove boxes

Features

excellent price/performance ratio
 compact housing
 easy and fast mounting

Technical Data

Measuring values

Working range ¹⁾	0...1m/s (0...200ft/min)	
	0...2m/s(0...400ft/min)	
Output signal ¹⁾	0-5V (max. 1mA)	
0...1m/s / 0...2m/s	0-10V (max. 1mA)	
Accuracy ²⁾ at 20°C / 68°F / 45%RH and 1013hPa	0.2...1m/s (40...200ft/min): ±(0.05m/s +2% of m.v.)	0.2...2m/s (40...400ft/min): ±(0.08m/s +4% of m.v.)
Response time at 1m/s (200ft/min) t ₉₀	typ. 4 sec.	

General

Supply voltage ¹⁾	10 - 19V DC or 19 - 29V DC	
Current consumption	max. 70mA at 2m/s (400ft/min)	
Working range	humidity:	10...95% RH (non-condensing)
	working temperature:	0...60°C (32...140°F)
	storage temperature:	-30...60°C (-22...140°F)
Connection	0.5m cable, PVC 3x0.25mm ² with cable end sleeves	
Electromagnetic compatibility	EN61326-1	
	EN61326-2-3	
Housing / Protection class	polycarbonate / IP20 (sensor); IP40 (housing)	



¹⁾ refer to ordering guide

²⁾ The accuracy statement includes the uncertainty of the factory calibration with an enhancement factor k=2 (2-times standard deviation).
 The accuracy was calculated in accordance with EA-4/02 and with regard to GUM (Guide to the Expression of Uncertainty in Measurement).

Dimensions (mm)

Probe:

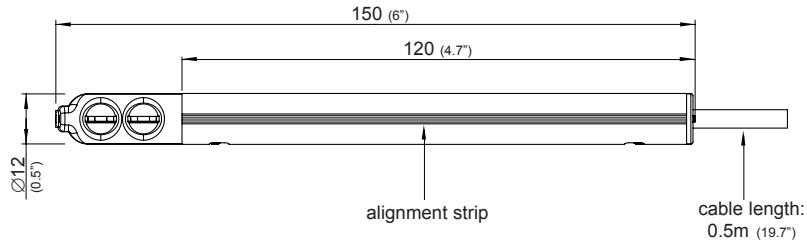

Front view sensor head:

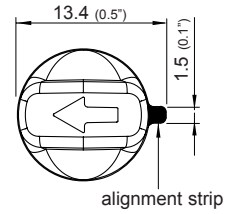

Flange (included in the scope of supply):

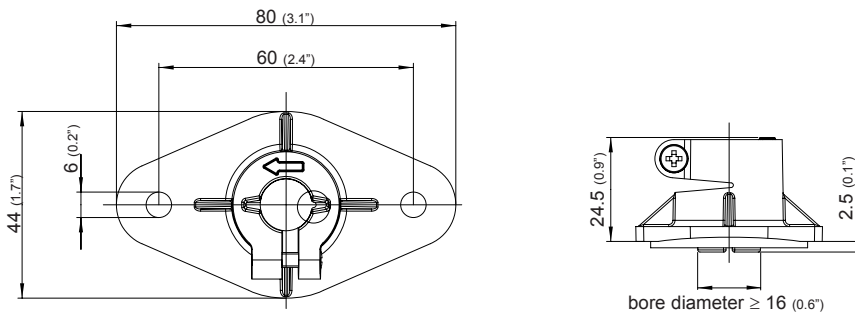

Cable Assignment

white → V+
brown → GND
green → output signal

Ordering Guide

MODEL	OUTPUT	WORKING RANGE	SUPPLY	CABLE LENGTH
air velocity	(V) 0 - 5V	(2) 0...1m/s (0...200ft/min)	(A) 10 - 19V DC	(1) 0,5m (no code)
	0 - 10V ¹⁾	(3) 0...2m/s (0...400ft/min)	(B) 19 - 29V DC	(2) 2m (K200)
EE576-				

1) with supply 19-29V DC only

Order Example

EE576-V2B1K200

Model: air velocity
Output: 0 - 5V
Working range: 0...2m/s
Supply: 10 - 19V DC
Cable length: 2m