



Objekterkennung

O2M113

Ethernet Kamera

Öffnungswinkel 115°

Scheibenheizung

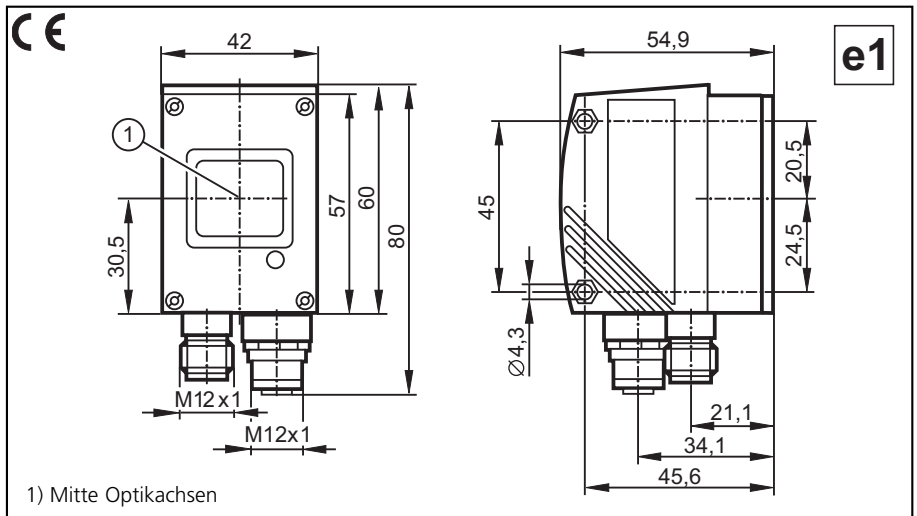

Elektrische Ausführung

Arbeitsabstand	[m]
Bildfeldgröße	[m]

Betriebsspannung	[V]
Leistungsaufnahme	[W]
Scheibenheizung	[W]

Sensorart	
Bildwiederholrate	[Hz]
Protokoll	
Datenformat	

Betriebsbereitschaftsanzeige	[LED]
Umgebungstemperatur	[°C]
Lagertemperatur	[°C]

Schutzart, Schutzklasse

Normen, Prüfungen

Werkstoffe

Schnittstelle

Übertragungsrate

IP Adresse (Default)

Anschlussbelegung

DC

-	1	2	5	-	-
-	3,1 x 1,8	6,2 x 3,7	15,7 x 9,3	-	-

8...32 DC

typ. 4 (excl. Scheibenheizung)

typ. 6

CMOS Bildsensor Color, QVGA-Auflösung 320 x 240

min. 15

Bildübertragung mit UDP/IP

8 Bit Windows® Bitmap Format / Bildformat QVGA

grün

-30...75

-40...85

IP 69K, III

DIN EN 61326 / IEC 60255-5 / DIN EN 61373 Kat. 1B / KFZ-Richtlinie 05 /49/EG (e1)

Gehäuse: Zink-Druckguss / Beschichtung: kathodische Tauchlackierung (KTL)
Frontscheibe: Glas

Ethernet 10Base-T / 100Base-TX

10/100 MBit/s (einstellbar)

192.168.82.15

Versorgungsanschluss:
M12, 4-polig



- 1: U+
- 2: nicht belegt
- 3: 0 V
- 4: nicht belegt

Parametrieranschluß:
M12, 4-polig, D-kodiert



- 1: TD+
- 2: RD+
- 3: TD-
- 4: RD-



Object recognition

O2M113

Ethernet camera

Angle of aperture 115°

Lens heating

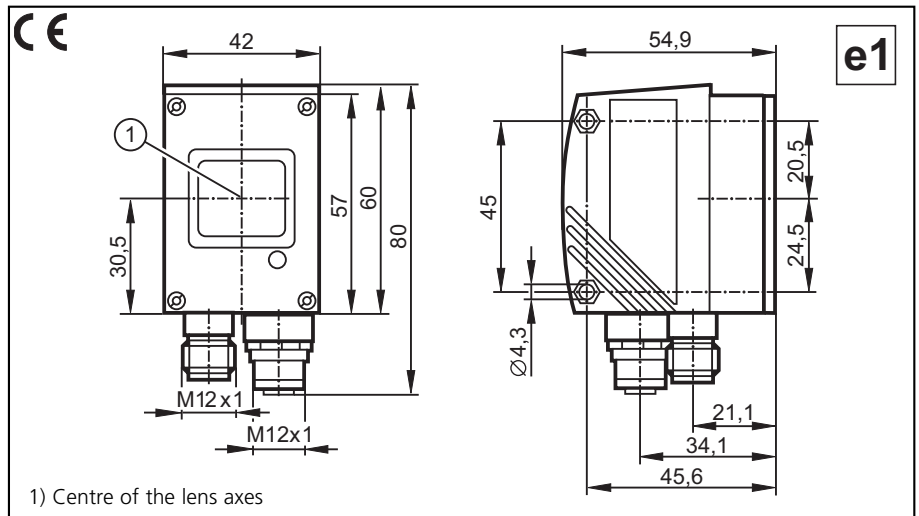

1) Centre of the lens axes

Electrical design

Operating distance	[m]
Field of view size	[m]

Operating voltage	[V]
Power consumption	[W]
Lens heating	[W]

Type of sensor	
Image repetition rate	[Hz]
Protocol	
Data format	

Readiness for operation	[LED]
Operating temperature	[°C]
Storage temperature	[°C]

Protection	
Standards, tests	

Materials	
-----------	--

Interface	
-----------	--

Transmission rate	
-------------------	--

IP address (default)	
----------------------	--

Wiring	
--------	--

DC

-	1	2	5	-	-
-	3.1 x 1.8	6.2 x 3.7	15.7 x 9.3	-	-

8...32 DC
typ. 4 (excl. lens heating)
typ. 6

CMOS image sensor colour, QVGA resolution 320 x 240
min. 15
image transmission via UDP/IP
8-bit Windows® bitmap format / image format QVGA

green
-30...75
-40...85

IP 69K, III
DIN EN 61326 / IEC 60255-5 / DIN EN 61373 cat. 1B / Automotive Directive 05/49/EC (e1)

housing: diecast zinc / coating: cathodic dip painting (KTL)
front lens: glass

Ethernet 10Base-T / 100Base-TX

10/100 Mbits/s (adjustable)

192.168.82.15

Power supply connection:
M12, 4-pole

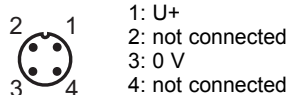

Parameter setting connection:
M12, 4-pole, D-coded

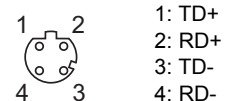



Reconnaissance d'objets

O2M113

Caméra Ethernet

Angle d'ouverture 115°

Chauffage de la face
optique

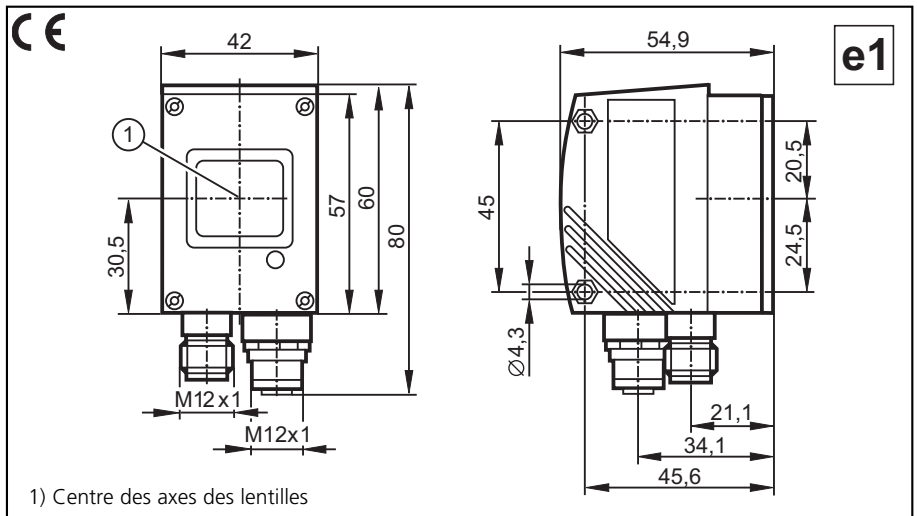

Version électrique

Portée de travail	[m]
Taille du champ de vue	[m]

Tension d'alimentation	[V]
Puissance absorbée	[W]
Chauffage de la face optique	[W]

Type de détecteur	
Taux de répétition des images	[Hz]
Protocole	
Format des données	

Indication de disponibilité	[LED]
Température ambiante	[°C]
Température de stockage	[°C]

Protection	
Tests et homologations	

Matières

Interface

Taux de transfert

Adresse IP (par défaut)

Branchement

DC

-	1	2	5	-	-
-	3,1 x 1,8	6,2 x 3,7	15,7 x 9,3	-	-

8...32 DC

typ. 4 (excl. chauffage de la face optique)

typ. 6

détecteur d'images en couleur CMOS, résolution QVGA 320 x 240

min. 15

transmission d'images via UDP/IP

format Windows® bitmap 8 bits / format d'image QVGA

verte

-30...75

-40...85

IP69K, III

DIN EN 61326 / CEI 60255-5 / DIN EN 61373 cat. 1B / directive automobile 05 /49/CE (e1)

boîtier : zamac / revêtement : par immersion cathodique (KTL)

fenêtre avant : verre

Ethernet 10Base-T / 100Base-TX

10/100 Mbit/s (réglable)

192.168.82.15

Raccordement d'alimentation :
M12, 4 pôles



- 1: U+
- 2: non raccordé
- 3: 0 V
- 4: non raccordé

Raccordement de paramétrage :
M12, 4 pôles, codage D



- 1: TD+
- 2: RD+
- 3: TD-
- 4: RD-