



32 57303B00

Overexcitation rectifier with integrated motor current detection

Overexcitation rectifiers with integrated current sensors are designed to be fitted to motor, brake or magnet connector boxes. As switching operations are determined by the motor current, these rectifiers provide braking times that would otherwise only be possible with additional DC side switching. Dynamic requirements in terms of quick motor stopping can be satisfied by using this type of brake rectifier without necessitating additional lines and external contacts for DC side brake switching. The special rectifier and current sensor combination provides electronic DC side switching directly within the rectifier. Owing to the integrated overexcitation, these rectifiers also ensure rapid brake release times and thus minimal wear during motor start-up as well as reduced motor starting current and energy consumption of the brake. Various mounting and connection features and accessories make these rectifiers suitable for equally varied applications as the 32 x7x2x.. series (Universal Collection). All series are equivalent in terms of their mechanical design and connection features and thus fully interchangeable.

Technical specifications

Rectifier principle		time-controlled change over from bridge to half-wave rectification				
DC side switching		with integrated motor current detection				
Ambient temperature		(°C)	-25 ... 85	Derating for motor and load current: see diagram		
Motor current detection range		(A AC)	0.6 ... 10			
Transient overload capacity of current detection		(f(I _{Mn}))	- 7 * I _{Mn}			
Disconnection delay		(ms)	20 ms	at 50 Hz, I _M = 0.6 A		
Disconnection voltage		(V)	ca. 300 V	at I = 0,7 ADC		
Maximum permitted energy absorption of switching voltage limitation		(J)	28	for 2 ms		
Type	Rated input voltage V₁ (tol.: ±10%) (40 – 60Hz) (VAC)	Output voltage V_{2OE} / V_{2H} (f(V₁))	Max. output current I_{OE} / I_H (ADC)	Over-excitation time t_{OE} (tol.: ±20%) (ms)	Housing L x H x W (mm)	Connections
32						
57303 B00	220 - 415	0.89 / 0.445 * U ₁	1.4 / 0.7	300	50 x 30 x 22	5 (6) terminals 1.5mm ² fine wire, 2.5mm ² single wire

Permitted current load at ambient temperature

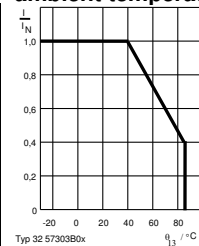

Protection:
as per EN 60529: IP 00

Specification subject to change without notice. Please observe ordering data!

CE

EMC Directive 2004/108/EEC:

Compliance with the following standards is confirmed:

- EN 50081-2 (Emission):
- EN 55011 (VDE 0875, part 11, 1992)
- Group 1, Class A conducted interference
- Group 1, Class B radiated interference
- EN 61000-6-2 (Immunity):
- EN 61000-4-3 (1997) severity level 3
- EN 61000-4-4 (1996) severity level 3
- EN 61000-4-5 (1996) severity level 3

Low Voltage Directive 2006/95/EEC:

Compliance with the following standards is confirmed:
HD 625.1S1 (1996), (VDE 0110) insulation coordination, EN 60529 (1991) IP 54 external mounting

Machinery Directive 2006/42/EC: These products are considered components in the sense of Machinery Directive 2006/42/EC and must not be put into service until the machinery in which they are incorporated has been declared in conformity with the provisions of the EC Directives.

ROHS

The specified products comply with Directive 2002/95/EC (ROHS).

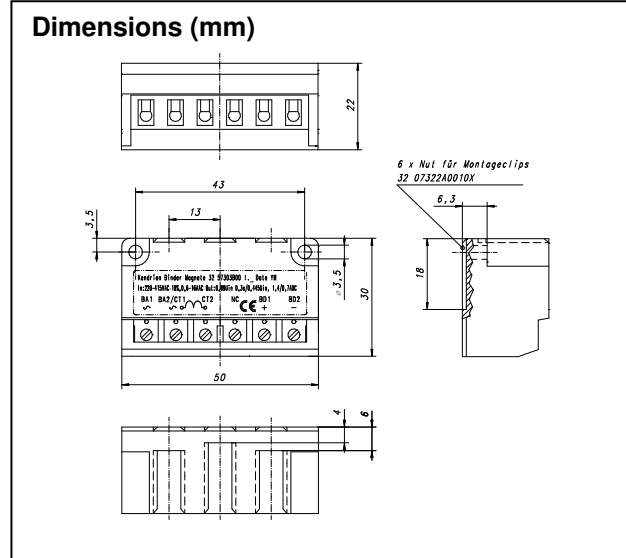
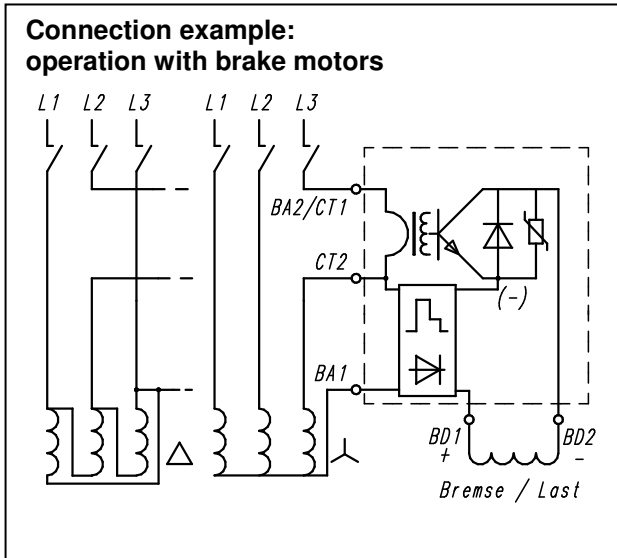

Accessories

Using a dovetail keyway, the clips or straps are to be connected with the rectifier in such a way that a flexible installation is ensured.

Mounting rail clip set: 32 07322A00103

Mounting clip for 35mm mounting rails in accordance with EN50022 and EN50045
1 set = 2 clips per rectifier

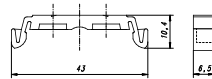
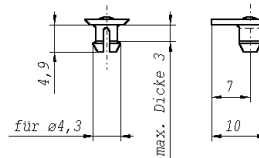

Figure similar to design

Clip:

32 07322A00101

Mounting clip for bores with a diameter of 4.3 mm
1 or 2 clips per rectifier



Adhesive pad:

32 07322A00104

Double-sided adhesive tape for mounting on smooth surfaces
1 pad per rectifier

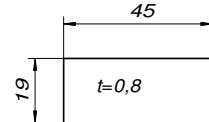

Operation and connection

Rectifiers with current detection have been specifically designed for quick start and braking of electric motors. The terminals marked "BA2/CT1" and "CT2" are connected in series with a motor winding, which current can't flow between "CT1" and "CT2" if the motor will be switched off. A current flow, which could be generated in case of the motors runout between motor coil and brake doesn't influence the response time of the brake if the wiring is made according to figure "Connection example". The common circuit termination of current sensor and rectifier reduces the wiring complexity, if it is made as shown in the example or analogue.

Attention!

The brake is switched off if the current sensor has not been connected correctly or in case of an insufficient motor current flow or phase failure. In this case, it must be ensured that continuous motor operation is inhibited when the brake is not released as this would cause damage to the brake, magnet

or rectifier. Any motor change-over during operation which would cause the current flowing through the "CT" terminals to fall below the minimum switching current for over 10 ms is not allowed as this may cause the brake to engage. The "AC" input of the rectifier is "CT2" and "BA1". It isn't potential-separated from the current sensor.

Attention!

Switching operations must take place in such a way that a dead time at least as long as the overexcitation time specified for the rectifier is observed between disconnection and reconnection. Moreover, the mean power of the load reached as a result of the switching operations must not exceed its rated power in order to avoid any thermal overload. Switch operation by switching only the current flow through the terminals "CT" without switching the "BA" terminals is not allowed due to dynamic overload of the rectifier. Furthermore the overexcitation will not work in this case.

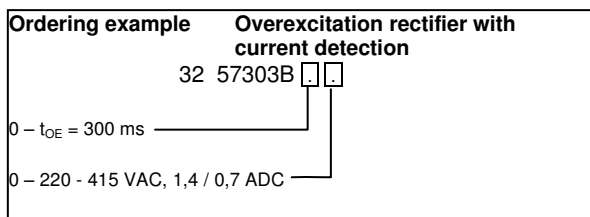

Kendrion (Villingen) GmbH

Wilhelm-Binder-Straße 4-6
78048 Villingen-Schwenningen
Germany

Phone +49 7721 877 1417
Fax +49 7721 877 1462
E-Mail sales-ids@kendrion.com
www.kendrion.com