

Bauformen

Designs

Formes de construction

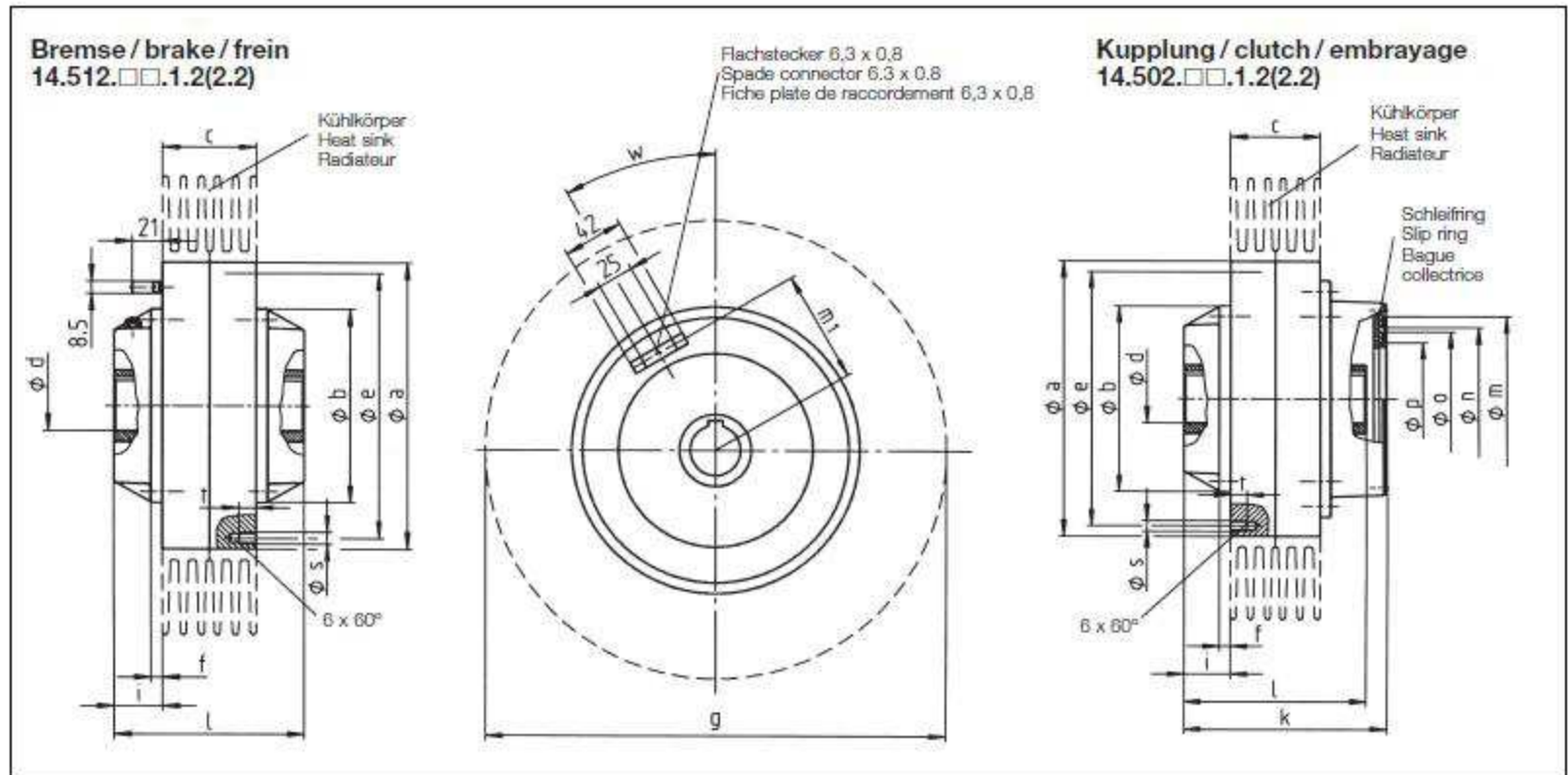

Größe Size Taille	M_K Nm	a_{s7}	$b_{j7}^{2)}$	c	$dH7$				e	f	g	i	k	l	m_1	m	n	o	p	q	s	t	w
					Standard	max																	
01	10	100	70	45	10	12	-	14 ¹⁾	90	5	160	20	97	85	39	76	62	58	44	12	M 5	10	44°
02	20	120	80	50	14	16	19	20	110	4	200	24	108	98	47	76	62	58	44	10	M 6	10	30°
04	40	150	96	60	19	22	-	24	135	5	250	24	119	108	58	76	62	58	44	11	M 6	10	30°
08	80	200	135	65	28	32	-	35	185	8	320	33,5	147	132	82,5	120	104	98	82	15	M 8	12	30°
16	160	250	180	70	35	38	-	42	235	8	400	28	140,5	126	106	120	104	98	82	14,5	M 10	14	30°
32	320	320	235	80	48	55	-	60	300	10	480	35	165	150	137	142	126	120	104	15	M 10	16	30°

Bohrungen mit Nut nach DIN 6885/1
 1) Bohrung mit Nut nach DIN 6885/3
 2) Zentrierung und Planlauf der Anschraubfläche nach DIN 42955-R

Bores with keyway to DIN 6885/1 (BS 4235)
 1) Bores with keyway to DIN 6885/3
 2) Tolerances of mounting surface to DIN 42955-R

Alésages avec rainure selon DIN 6885/1
 1) Alésages avec rainure selon DIN 6885/3
 2) Centrage et planéité de la face de fixation selon DIN 42955-R