



WE MAGNETISE THE WORLD



Permanent magnet brakes

Safety from the market leader

PM Line
High Torque Line



INDUSTRIAL DRIVE SYSTEMS

BINDER

Kendrion – The brake experts

As a solution provider, Kendrion develops, produces and markets innovative and high-quality electromagnetic and mechatronic systems and components for industrial and automotive applications. Kendrion is very serious about its commitment to addressing the technical challenges of the future. Which is why the responsible use of resources along the entire value chain, and trustworthy business practices, are deeply ingrained in our corporate culture.

The right brakes for every situation

The Industrial Drive Systems business unit develops and produces electromagnetic brakes and clutches for industrial drive engineering. They are used for the accelerating, braking, positioning, holding and securing of movable drive components and loads. The areas of application for our brakes and clutches are primarily in robotics and automation technology, machine tool and production machinery, as well as in medical technology and material handling.

'Servo Line', our newly designed spring-applied brake for servo motors, completes our product portfolio, enabling us to provide the ideal solution for any application.

Worldwide availability

The headquarters of Industrial Drive Systems is located in Villingen within Germany's Black Forest. However, the business unit can also rely on additional production sites and subsidiaries in Aerzen (Germany), China, the UK and Italy, as well as numerous sales partners all over the world.

Tradition and progress

It was the long-established BINDER brand that laid the foundations for the successful development of Industrial Drive Systems. Wilhelm Binder founded his company in 1911, and during the early 1920s he began developing and manufacturing electromagnetic components. In 1997, the business was taken over by Dutch group Schuttersveld N.V., today Kendrion N.V.

The former magneta GmbH & Co. KG has been part of the Kendrion Group since 2010. Now known as Kendrion (Aerzen) GmbH, this innovative company continues to develop and produce permanent magnet brakes for small motors, electromagnetic clutches and brakes at its site in Aerzen, along with magnetic particle clutches and brakes.

Kendrion – We magnetise the world!

www.kendrion-ids.com



Branches and applications

Automation and robotics



Medical



Packaging and conveying



Safety and comfort



Renewable energy



Customised applications



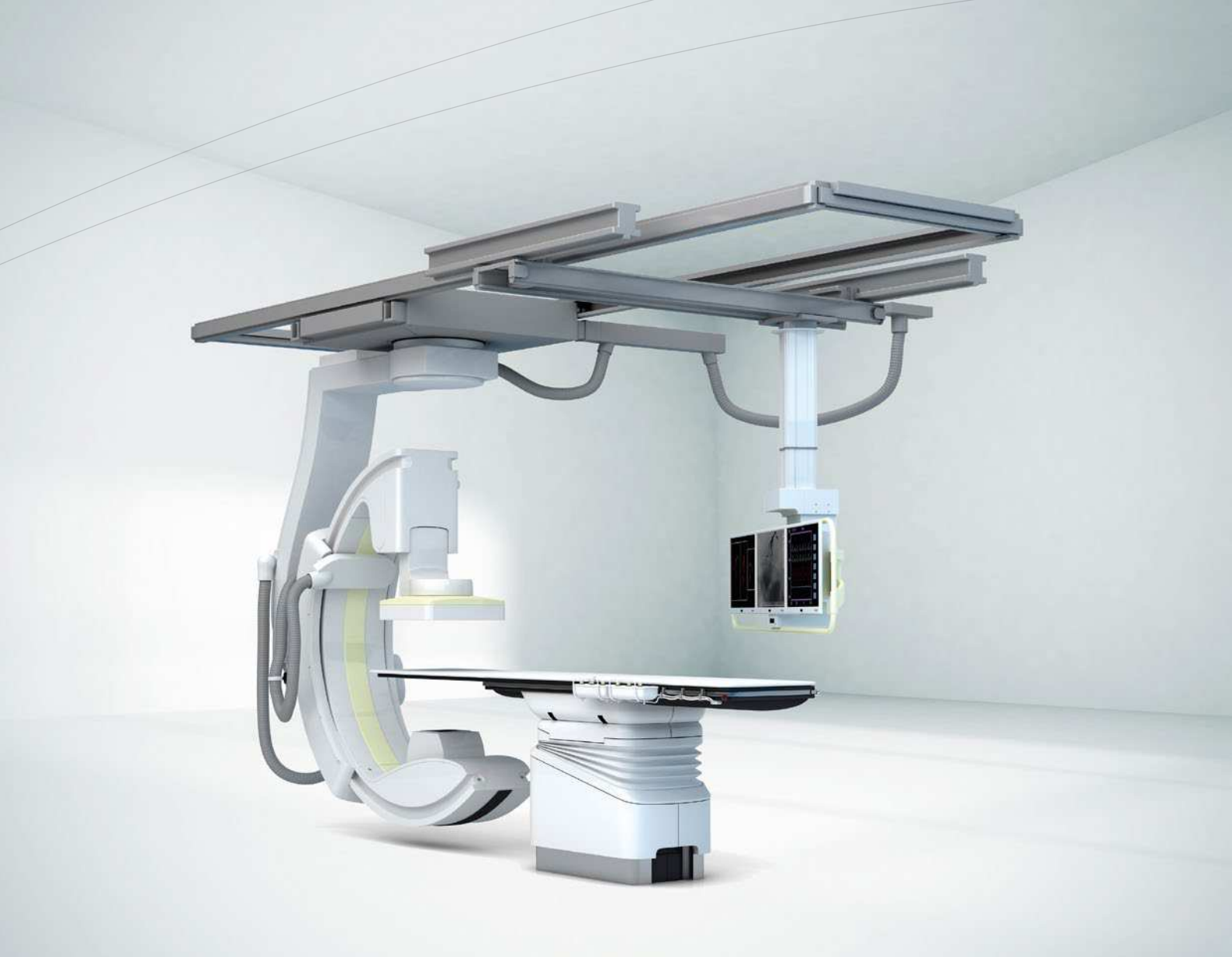

PM Line

Classic permanent magnet brakes

Permanent magnet brakes excel in particular by their compact dimensions and their comparatively low weight. Due to the high power density of the permanent magnets the torque that can be achieved at a given installation space is twice as high as with common spring-applied brakes.

Furthermore, due to their design principle permanent magnet brakes are free of backlash and wear. Permanent magnet brakes are thus ideally suited for applications in medical engineering and servomotor applications, e.g. in handling technology and robotics.

The smallest permanent magnet brake of the world

...is smaller in diameter (14 mm) than a one-cent coin, thus finding place in smallest electric motors.

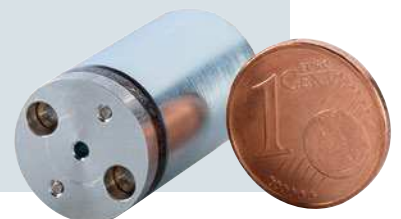

About the PM Line

The PM Line includes permanent magnet single-disc brakes for direct current in which the braking effect is generated by a permanent magnetic field (system opened by electro-magnetic force). The brake thus acts in currentless state when switched off. In order to neutralize the braking effect the permanent magnetic field is displaced by an opposing electro-magnetic field. The PM Line excels by safe, residual torque-free lifting in any mounting position and by backlash-free transmission of the braking torque. These brakes are particularly suitable for applications in the field of servomotors as holding brakes with or without emergency stop function.

Model types

86 611..H00; 14.120.xx.2xx

Torque range from 0.01 to 120 Nm
DC direct current
Face mounting
Single-disc brake

86 621..H00; 14.120.xx.1xx

Torque range from 0.01 to 120 Nm
DC direct current
Flange mounting
Single-disc brake

Applications

- Servomotors
- Packaging machines
- Conveyor technology
- Handling technology
- Optics and medical engineering
- Wheelchairs

General information

When planning the machine (e.g. motor) or plant as well as during setup, operation and maintenance of the component the operating instructions have to be observed. The components are manufactured, tested and designed according to the state of the art, in particular in accordance with the regulations for electro-magnetic devices and components (DIN VDE 0580). In addition to the technical data in the data sheets you find comments in the operating instructions.

We are happy to discuss your individual requirements and develop your specific version. The following features can be adapted:

- Hub diameter of optional felt ring*
- Against lubricants*
- Individual hub design*
- Strand protection*
- Mass inertia-optimized system*



Model type face mounting

Model types	86 611..H00 – face mounting 14.120.xx.2xx
Standard rated voltage	24 VDC, 205 VDC
Protection class	IP 00
Thermal class	F (B for 14.120.xx.2xx)
Nominal torques	0.01 to 120 Nm
Options	Organic friction pad
Note	Please observe the general information on data sheets and the respective operating manuals. Design subject to change.



Size		Transmissible torque M_4 [Nm]	Max. rotational speed n_{max} [min ⁻¹]	Max. switch. capacity P_{max} [kJ/h]	Max. switching energy (Z = 1) W_{max} [kJ]	Rated power P_N [W]	Times		Inertia moment armature and flange hub J [kgcm ²]	Weight m [kg]
86 611..H00	14.120.xx.2xx						Coupling time (with parallel varistor) t_1 [ms]	Separation time t_2 [ms]		
	01 ¹⁾	0.01	20000	–	–	1.8	–	–	0.0006	0.02
	02	0.1	49000	0.006	0.0003	2.5	12	16	0.0018	0.029
	02 ¹⁾	0.08	16000	–	–	3.3	–	–	0.0056	0.09
	03	0.4	16000	0.2	0.01	6.2	13	27	0.010	0.07
	03	0.6	12000	–	–	10	–	–	0.018	0.1
	04	2.2	12000	4	0.2	8	14	28	0.12	0.19
	06	3.2	10000	7	0.35	12	19	29	0.38	0.3
	07	11	10000	8	0.4	16	20	29	1.06	0.6
	09	22	10000	11	0.55	18	25	50	3.6	1.1
	11	40	10000	17	0.85	24	25	73	9.5	1.4
	14	80	8000	29	1.45	35	53	97	31.8	4.1
	16	120	8000	31	1.55	37	80	150	57.5	6

¹⁾ Pure holding brake

Model type flange mounting

Model types	86 621..H00 – flange mounting 14.120.xx.1xx
Standard rated voltage	24 VDC, 205 VDC
Protection class	IP 00
Thermal class	F (B for 14.120.xx.1xx)
Nominal torques	0.01 to 120 Nm
Options	Organic friction pad
Note	Please observe the general information on data sheets and the respective operating manuals. Design subject to change.



Size	Transferable torque	Max. rotational speed	Max. switch. capacity	Max. switching energy (Z = 1)	Rated power	Times		Inertia moment armature and flange hub	Weight
						Coupling time (with parallel varistor)	Separation time		
86 621..H00 14.120.xx.1xx	M ₄ [Nm]	n _{max} [min ⁻¹]	P _{max} [kJ/h]	W _{max} [kJ]	P _N [W]	t ₁ [ms]	t ₂ [ms]	J [kgcm ²]	m [kg]
01 ¹⁾	0.01	20000	–	–	1.8	–	–	0.0006	0.02
03	0.4	16000	0.2	0.01	6.2	13	27	0.010	0.07
03	0.6	12000	–	–	10	–	–	0.018	0.12
04	2.2	12000	4	0.2	8	14	28	0.12	0.19
05	4	10000	–	–	12	–	–	0.22	0.45
06	3.2	10000	7	0.35	12	19	29	0.38	0.3
07	11	10000	8	0.4	16	20	29	1.06	0.6
09	22	10000	11	0.55	18	25	50	3.6	1.1
11	40	10000	17	0.85	24	25	73	9.5	1.4
14	80	8000	29	1.45	35	53	97	31.8	4.1
16	120	8000	31	1.55	37	80	150	57.5	6

¹⁾ Pure holding brake

Device dimensions

Type 86 611[02-16]H00 for face mounting

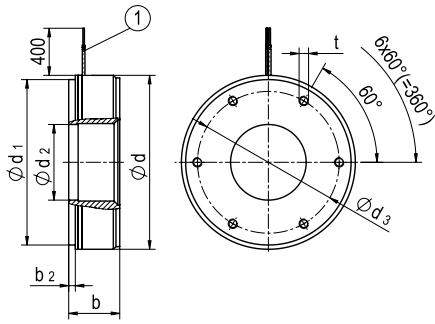

Type 86 621[02-16]H00 for flange mounting

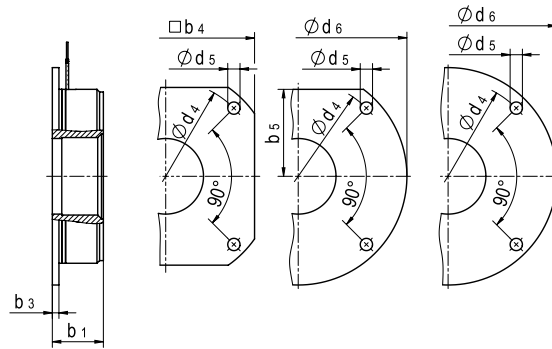

① Strand diameter x [mm²]

Size	d	d ₁	d ₂	d ₃	d ₄	d ₅	d ₆	b	b ₁	b ₂	b ₃	b ₄	b ₅	t	x [mm ²]
01 ¹⁾	14	14	4	8.5	–	–	–	14	–	2	–	–	–	M1.6	0.15
02	19.3	19	5	16.4	–	–	–	20.9	–	4	–	–	–	M2	0.09
02 ¹⁾	23.5	23.5	9	16	–	–	–	17.5	–	–	–	–	–	M3	0.25
03	28	28	9	22	33.5	2.6	–	16	16	3.3	1.5	30	–	M2	0.25
03 ¹⁾	31	31	13	24	36	2.9	42 h10	23.7	23.7	3	3	–	–	M3	0.25
04	39.5	40	13	32.5	54	3.5	–	21	23	4.9	2	45	–	M2	0.25
05 ¹⁾	54.5	–	26	–	58	3.4	65 h9	–	40.2	2	2	–	–	–	0.25
06	56	53	24	48	65	4.5	75 h8	20.8	20.8	3	3.1	–	28	M3	0.25
07	70	66.5	30	61	79.5	5.5	90 h8	25.3	25.3	3.5	3.5	–	35	M3	0.25
09	90	85.5	40	75	102	6.5	115 h8	26.7	26.7	3.5	3.5	–	45	M3	0.25
11	110	104	50	90	121	6.5	132 h8	30.7	30.7	5	5	–	–	M4	0.62
14	140	134	70	120	151	6.5	162 h8	37.2	37.2	6.5	6.5	–	–	M5	0.96
16	160	160	80	120	175	9	190 h8	43.2	43.2	12	7	–	–	M5	0.62

¹⁾ Device dimensions for type 14.120.xx.2 xx and xx 14.120.xx.1 (without illustrations - drawings on demand)

Dimensions in mm

Armature dimensions

Type 200

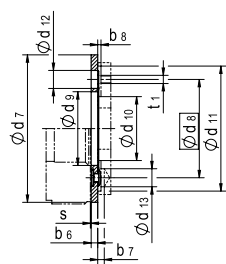

Hole pattern for armature reception type 200

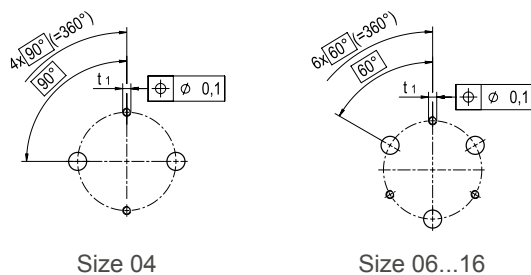

Type 300

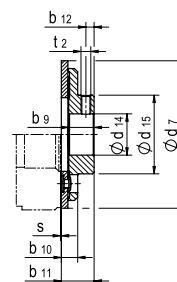

Type 400

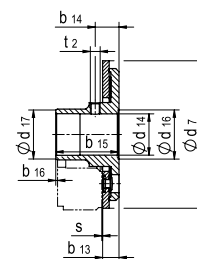

Connecting part out of non-magnetizable material. Cut out for spring segments $\varnothing d_{10}$ to $\varnothing d_{11}$; depth = $b_8^{+0.05}$.

Size	d ₇	d ₈	d ₉	d ₁₀	d ₁₁	d ₁₂	d ₁₃	d ₁₄	d ₁₅	d ₁₆	d ₁₇	b ₆
01 ³⁾	14	–	–	–	–	–	–	1.5 / 3	–	–	4.6	1.5
02	18.6	–	–	–	–	–	–	3 ¹⁾ / 4 ²⁾	10.5	–	–	1
02 ³⁾	23	14.5	8	–	–	4.5	–	4 / 5	9.8	–	–	2
03	28.5	–	–	–	–	–	–	4 ¹⁾ / 8 ²⁾	14	upon request	upon request	2
03 ³⁾	31	19.5	12.5	–	–	5	–	5 / 8	13			2.3
04	39.5	29	17	16	37	7	7	6 ¹⁾ / 8 ²⁾	16			4.9
05 ³⁾	54	38	29	–	–	6.5	–	10 / 15	24			2.8
06	56	46	28	35	54	7	7	6 ¹⁾ / 15 ²⁾	24			3
07	70	60	37	46	68	8.5	8.5	10 ¹⁾ / 22 ²⁾	30			3.5
09	90	76	46	60	88	10.5	10.5	10 ¹⁾ / 30 ²⁾	40			4
11	110	95	59	78	108	12	12	15 ¹⁾ / 35 ²⁾	50			5
14	140	120	75	98	136	16	16	20 ¹⁾ / 48 ²⁾	70			6.5
16	160	135	83	113	156	16	16	20 ¹⁾ / 62 ²⁾	79			7

Size	b ₇	b ₈	b ₉	b ₁₀	b ₁₁	b ₁₂	b ₁₃	b ₁₄	b ₁₅	b ₁₆	s	t ₁	t ₂
01 ³⁾	–	–	–	–	7	–	3.7	–	7	–	0.09 ±0.01	–	–
02	–	–	6.1	3.9	7.1	1.6	–	–	–	–	0.1 ±0.02	–	2x M2.5
02 ³⁾	–	–	7	4.1	9.1	2.5	–	–	–	–	0.12 ^{+0.05} _{-0.03}	–	1x M3
03	–	–	8.5	5	10.5	3.5	–	–	–	upon request	0.15 ^{+0.06}	–	2x M3
03 ³⁾	–	–	8	4.3	10.3	3.5	–	–	–		0.15 ^{+0.1} _{-0.05}	–	1x M3
04	2.2	1.5 ^{+0.05}	15	8.4	17.5	6	–	–	–		0.2 ^{+0.1}	M3	2x M3
05 ³⁾	–	–	12	6	15	5	–	–	–		0.2 ^{+0.1} _{-0.05}	–	1x M4
06	2.8	1 ^{+0.05}	17	8	20	6	8.5	15	29		0.2 ^{+0.1}	M3	2x M3
07	3	1.2 ^{+0.05}	20	9.5	23.5	7	10	13	35		0.3 ^{+0.1}	M4	2x M4
09	4	1.3 ^{+0.05}	25	12	29	7	10.6	20	37		0.3 ^{+0.1}	M5	2x M5
11	5	1.6 ^{+0.05}	30	14	35	11	13	22.5	43.5		0.3 ^{+0.1}	M6	2x M6
14	6	2.3 ^{+0.05}	40	16	46.5	15	16.5	29.5	53.5		0.3 ^{+0.1}	M8	2x M8
16	6	2.8 ^{+0.05}	40	16.5	47	15	–	–	–		0.3 ^{+0.1}	M8	2x M8

¹⁾ Min. bore

²⁾ Max. bore

³⁾ Anchor dimensions for type 14.120.xx.2 xx and xx 14.120.xx.1 (without illustrations - drawings on demand)



High Torque Line

Permanent magnet brakes with high torque

Due to their high power density, wear- and residual torque-free operation and short switching cycles permanent magnet brakes are in most cases the optimum solution in robotics and machine building. With respect to voltage tolerances and operating temperatures, however, the conventional design of the permanent magnet brake may reach its limit. Taking advantage of a completely new setup of the magnetic circuit these limits can be overcome by the High Torque Line. This patented setup optimizes the magnetic flow while the coil is energized, i.e. when the brake is opened, thus allowing an operation at up to -40°C . Especially in case of highly demanding applications, e.g. in the safety area or with outdoor applications such as wind turbines, the brakes of the High Torque Line are the perfect choice.

Highest requirements to the holding moment

...are met by the High Torque Line even under extreme environmental conditions with widely varying ambient temperatures from -40°C to $+120^{\circ}\text{C}$.

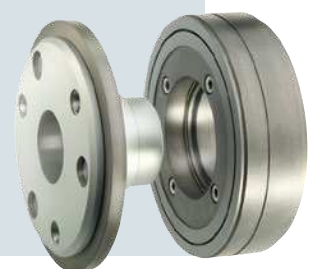

About the High Torque Line

The current High Torque Line is a complete re-design of the previous setup. The new setup of the magnetic circuit excels by enormous benefits:

- Higher torque with appr. same size and power consumption
- Significantly extended voltage and temperature range (-40°C to +120°C)
- High consistency of torque during the complete life cycle

Optimized geometry

By a new and patented arrangement of the poles and of the permanent magnet the magnetic flow is ideally controlled, resulting in the advantages mentioned.

Higher torque

While developing the High Torque Line we did not only succeed in increasing the braking torque (with roughly identical construction volume and identical electrical power input) but also in significantly improving the consistency of the torque over the whole life cycle.

Model types

86 611..K00

Torque range from 0.4 to 300 Nm
DC direct current
Face mounting
Single-disc brake (holding brake)

86 611..P00

Torque range from 0.4 to 300 Nm
DC direct current
Face mounting
Single-disc brake (holding brake)

Applications

- Servomotors
- Robotics and automation
- Wind energy and other outdoor applications
- Safety engineering
- Optics and medical engineering

General information

When planning the machine (e.g. motor) or plant as well as during setup, operation and maintenance of the component the operating instructions have to be observed. The components are manufactured, tested and designed according to the state of the art, in particular in accordance with the regulations for electro-magnetic devices and components (DIN VDE 0580). In addition to the technical data in the data sheets you find comments in the operating instructions.

We are happy to discuss your individual requirements and develop your specific version. The following features can be adapted:

*Hub diameter of optional felt ring
Against lubricants
Individual hub design
Strand protection*



Permanent magnet single-disc brake

Model types	86 611..K00; 86 611..P00
Standard rated voltage	24 VDC
Protection class	IP 00
Thermal class	F
Nominal torques	0.4 to 300 Nm
Note	Please observe the general information on data sheets and the respective operating manuals. Design subject to change.

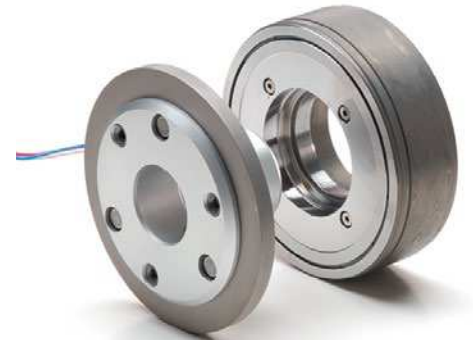

Size	Transmissible torque M_4 [Nm]	Max. rotational speed n_{max} [min ⁻¹]	Max. switch. capacity P_{max} [kJ/h]	Max. switching energy (Z = 1) W_{max} [kJ]	Rated power P_N [W]	Times		Inertia moment armature and flange hub J [kgcm ²]	Weight m [kg]
						Coupling time (with parallel varistor) t_1 [ms]	Separation time t_2 [ms]		
03	0.4	10000	0.2	0.01	6	13	24	0.019	0.1
04	2.5	10000	0.6	0.03	9	20	35	0.09	0.25
05	5	10000	0.6	0.03	12	25	50	0.39	0.4
06	9	10000	6	0.3	15	25	60	0.55	0.65
07	10	10000	6	0.3	14	25	90	0.8	0.6
08	15	10000	18	0.9	18	29	130	1.35	1.15
09	22	10000	18	0.9	19	40	100	2.73	1.2
10	32	10000	28	1.4	22.5	60	200	4.1	1.86
11	60	10000	40	2	25	50	220	14.7	3.1
14	80	10000	106	5.3	36.5	65	280	27	4.4
16	140	6000	106	5.3	43	60	450	48.6	5.9
21	300	6000	200	10	41.8	300	350	200	13

Device and armature dimensions

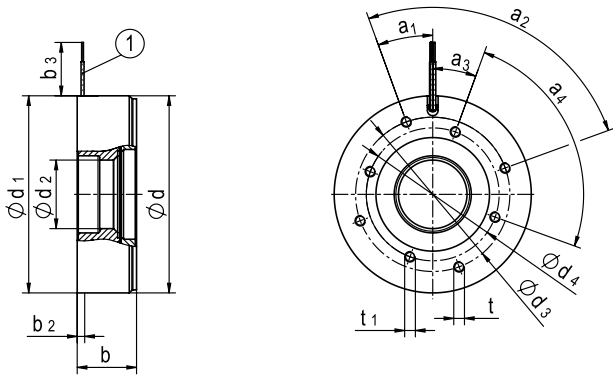

Type 300

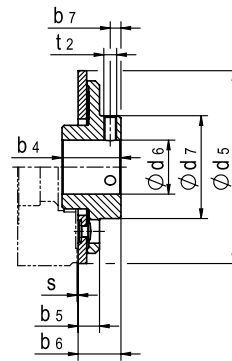

Type 400

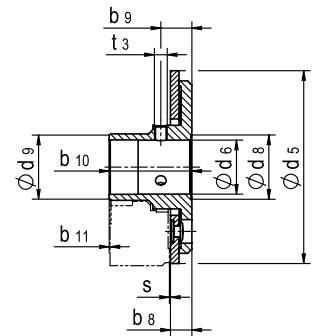

① Strand diameter x [mm²]

Size	d	d _{1/9}	d ₂	d ₃	d ₄	b	b ₂	b ₃	t	t ₁	a ₁	a ₂	a ₃	a ₄	x [mm ²]
03	32	32	9.6	27	—	19	5	400	3x M3	—	20°	120°	—	—	0.25
04	44	44	14.9	35	31	18.6	5	400	3x M3	3x M3	20°	120°	20°	120°	0.25
05	55	56	23	42	35	23.8	5	400	4x M4	4x M4	20°	90°	20°	90°	0.25
06	65	65	23	48	42	23.8	5	400	4x M4	4x M4	70°	90°	45°	90°	0.25
07	72	72	27	54	42	23.5	5	400	4x M4	4x M4	20°	90°	70°	90°	0.25
08	82	82	27	54	42	28.6	5	400	4x M4	4x M4	20°	90°	70°	90°	0.25
09	92	92	32	72	62	27.7	5	550	4x M5	4x M5	20°	90°	0°	90°	0.25
10	102	100	44	83	72	36.5	5	800	4x M6	4x M6	20°	90°	0°	90°	0.25
11	122	120	48.5	83	72	38	5	800	4x M6	4x M6	0°	90°	70°	90°	0.25
14	140	134	56.5	97	83	40.8	5	750	4x M8	4x M8	20°	90°	0°	90°	0.25
16	160	160	63	120	97	40.8	5	1000	6x M5	4x M8	30°	60°	0°	90°	0.62
21	205	200	90	167	—	56.1	10	1000	6x M8	—	30°	60°	—	—	0.62

Size	d ₅	d ₆	d ₇	d ₈	d ₉	b ₄	b ₅	b ₆	b ₇	b ₈	b ₉	b ₁₀	b ₁₁	s	t ₂	t ₃
03	32	4 ¹⁾ / 8 ²⁾	14	—	—	8.5	5	10.5	3.5	—	—	—	—	0.1 ^{+0.1}	2x M3	—
04	42.8	6 ¹⁾ / 10 ²⁾	37	upon request	upon request	12	8.1	8.1	2.5	8.1	2.5	26.7	upon request	0.15 ^{+0.1}	3x M3	3x M3
05	56	12 ¹⁾ / 17.2 ²⁾	56			16	10.7	10.7	3.6	10.7	3.6	34.5		0.2 ^{+0.1}	3x M4	3x M4
06	63	12 ¹⁾ / 18 ²⁾	51.5			18	4.8	10.5	3.5	10.5	3.5	34.2		0.2 ^{+0.1}	3x M4	3x M4
07	69.5	12 ¹⁾ / 20.2 ²⁾	38			17	7.3	15.3	4	7.3	10.6	30.8		0.2 ^{+0.1}	3x M5	3x M5
08	80	16 ¹⁾ / 20.2 ²⁾	40			17.5	7.4	15.5	4.1	7.4	10.4	35.8		0.3 ^{+0.1}	3x M5	3x M5
09	90	18 ¹⁾ / 26.2 ²⁾	48			27.5	10	20	5	10	14.5	37.9		0.27 ^{+0.1}	3x M6	3x M6
10	100	25.2 ¹⁾ / 36 ²⁾	85			30	4.5	15.2	5	15.2	5	51.9		0.3 ^{+0.1}	3x M6	3x M6
11	121	28 ¹⁾ / 36 ²⁾	94			40	8	22	7	14	20	52.2		0.4 ^{+0.1}	3x M8	3x M10
14	138	35 ¹⁾ / 40.2 ²⁾	78			41.3	15.5	28.8	7.3	15.5	22	56.5		0.3 ^{+0.1}	3x M10	3x M10
16	160	40.2	—			—	—	—	—	15.5	22	54		0.3 ^{+0.1}	—	3x M10
21	202	50 ¹⁾ / 65.2 ²⁾	195			59	12.3	24.3	—	24.3	31	77		0.4 ^{+0.1}	—	3x M12

¹⁾ Min. bore

²⁾ Max. bore

Dimensions in mm

Comparison of conventional permanent magnet brake and High Torque

Features	PM Line	High Torque Line
Residual torque-free	++	++
Higher torque	+	++
High power density	+	++
Optimized magnet system	+	++
Wear-free operation in all mounting positions	++	++
Torque consistency at low and high temperatures	+ (-5 to +120°C)	++ (-40 to +120°C)
High stability in operating voltage range	+	+
Easy, stress-free mounting	++	++
Application is easy to service	++	++

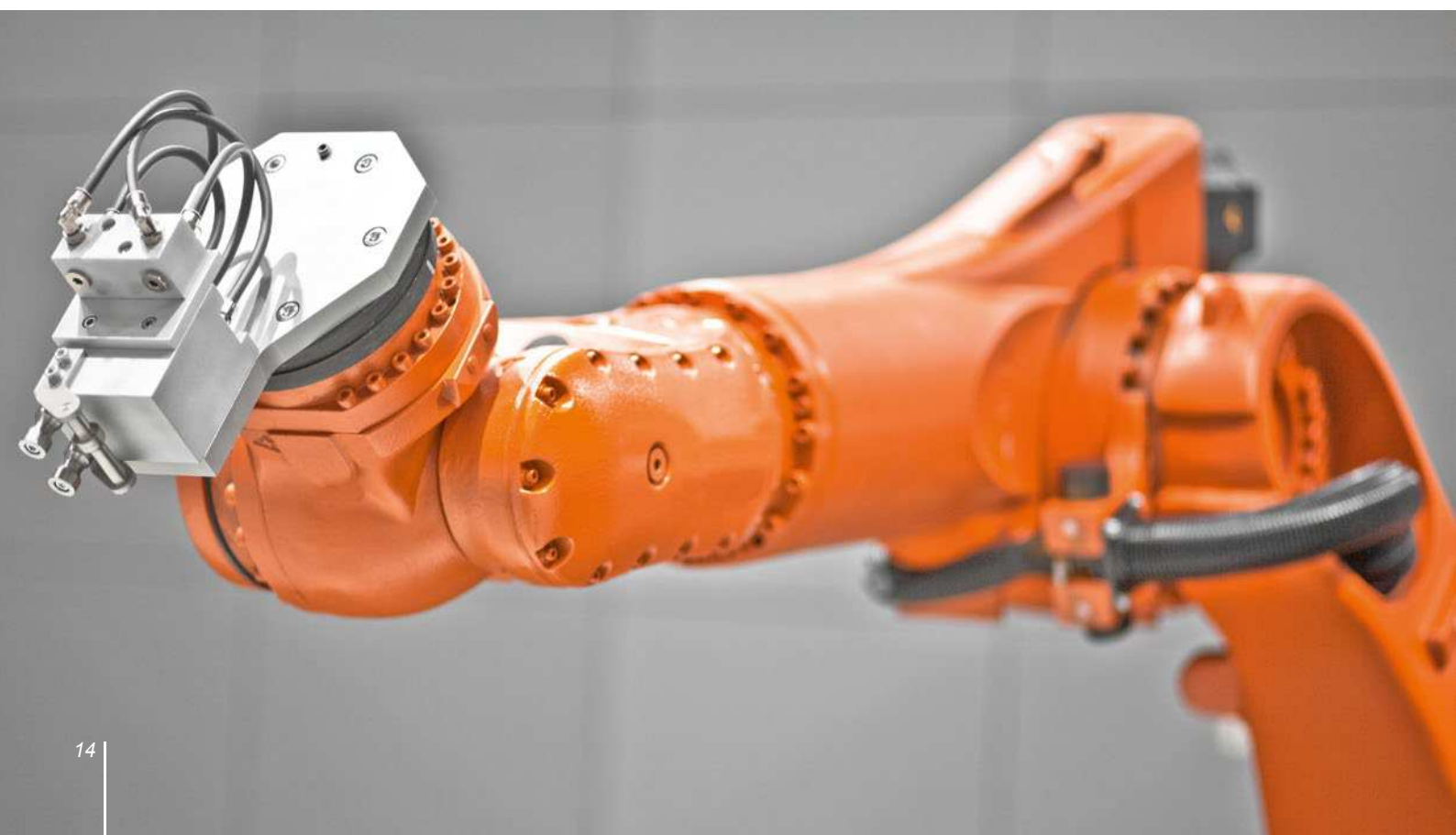

General technical information

List of abbreviations

M_4	[Nm]	Transmissible torque: highest torque that can be applied to the closed brake before slippage occurs. If only static load is applied to brakes M_4 is referred to as nominal torque.
n_{max}	[min ⁻¹]	Maximum rotational speed of motor shaft resp. armature system.
P_{max}	[kJ/h]	Highest switching performance: Permissible switching work converted to heat per time unit.
W_{max}	[kJ]	Highest switching work: maximum switching work permitted to load the brake.
Z	[h ⁻¹]	Switching frequency: number of switching operations evenly distributed over one hour.
U_N	[VDC]	Nominal voltage: designation or identification of allocated supply voltage with voltage coils.
P_N	[W]	Nominal voltage: rounded value of coil capacity at nominal voltage referred to 20°C.
t_1	[ms]	Coupling time: Sum of response delay t_{11} and rise time t_{12} .
t_{11}	[ms]	Response delay: time from switching off current to start of torque increase.
t_{12}	[ms]	Rise time: time from start of torque rise until 90% of torque is reached.
t_2	[ms]	Separation time: sum of response delay t_{21} and release time t_{22} .
t_{21}	[ms]	Response delay: time from switching on current to start of torque decrease.
t_{22}	[ms]	Decrease time: time from start of torque decrease until 10% of nominal torque is reached.
J	[kgcm ²]	Moment of inertia of armature system and flange hub.
s	[mm]	New air gap in new condition.
s_{Bmax}	[mm]	Maximum permitted operating air gap until maintenance of brake.

Operation

All given performance data always refer to the operating mode S1, in particular to the specified maximum temperature of the operating range of the brake. This corresponds to a permanent current feed of the brake until the steady-state temperature has been reached. In short-term operation S2 and intermittent operation S3 the performance data increases significantly.

Notes on the technical data

W_{max} (maximum switching work) is the switching work which must not be exceeded with braking processes from max. 3000min⁻¹. Braking processes from rotational speeds > 3000min⁻¹ significantly reduce the maximum permitted switching work per switching. In this case it is required to consult the manufacturer. The maximum switching performance P_{max} is the switching work W which can be implemented in the brake per hour. The permitted number of switchings (emergency stops) Z per hour with holding brakes and the resulting max. permitted switching work W_{max} is to be taken from the technical data and the respective operating instructions. In case of deviating applications, e.g. as a working brake, the manufacturer needs to be consulted. The values P_{max} and W_{max} are standard values. They are valid for installation without additional cooling. The coupling

time t_1 is achieved with operation at 110% of the rated voltage, maximum air gap s_{Bmax} , operational temperature (120°C) and operation with a suitable varistor. The separation time t_2 is achieved with operation at 90% of the rated voltage, smallest new air gap s and at operational temperature (120°C). The values given for the times are maximum values. The coupling time t_1 and the separation time t_2 are valid for DC-switching of the brake. In case of AC-switching of the brake the coupling time t_1 rises significantly. The specified transmissible torques M_4 signify the components in their minimum transmissible torque (statistical evaluation). Depending on the application the actually acting transmissible torque M_4 deviates from the values indicated for the transmissible torque M_4 . In case of oily, greasy or badly contaminated friction surfaces the transmissible torque M_4 may be reduced. All technical data are valid with due observance of the run-in conditions (see respective operating instructions) of the brake determined by the manufacturer.

When operating the permanent magnet single-disc brake the nominal operating conditions acc. DIN VDE 0580 must be observed! Please observe data sheet, operating instructions and the technical notes in the technical customer document!

Design subject to change!



WE MAGNETISE THE WORLD

Kendrion (Villingen) GmbH
Wilhelm-Binder-Strasse 4-6
78048 Villingen-Schwenningen
Germany
Tel: +49 7721 877-0
Fax: +49 7721 877-1462
sales-ids@kendrion.com
www.kendrion.com

Kendrion (Aerzen) GmbH
Dibbetweg 31
31855 Aerzen
Germany
Tel: +49 5154 9531-31
Fax: +49 5154 9531-41
magneta@kendrion.com
www.kendrion.com