



Classic Line

Spring-applied single-disc / multiple-disc brake

77 600..A00
77 600..A15
77 100..A00



Kendrion – The brake experts

As a solution provider, Kendrion develops, produces and markets innovative and high-quality electromagnetic and mechatronic systems and components for industrial and automotive applications. Kendrion is very serious about its commitment to addressing the technical challenges of the future. Which is why the responsible use of resources along the entire value chain, and trustworthy business practices, are deeply ingrained in our corporate culture.

The right brakes for every situation

The Industrial Drive Systems business unit develops and produces electromagnetic brakes and clutches for industrial drive engineering. They are used for the accelerating, braking, positioning, holding and securing of movable drive components and loads. The areas of application for our brakes and clutches are primarily in robotics and automation technology, machine tool and production machinery, as well as in medical technology and material handling.

'Servo Line', our newly designed spring-applied brake for servo motors, completes our product portfolio, enabling us to provide the ideal solution for any application.

Worldwide availability

The headquarters of Industrial Drive Systems is located in Villingen within Germany's Black Forest. However, the business unit can also rely on additional production sites and subsidiaries in Aerzen (Germany), China, the UK and Italy, as well as numerous sales partners all over the world.

Tradition and progress

It was the long-established BINDER brand that laid the foundations for the successful development of Industrial Drive Systems. Wilhelm Binder founded his company in 1911, and during the early 1920s he began developing and manufacturing electromagnetic components. In 1997, the business was taken over by Dutch group Schuttersveld N.V., today Kendrion N.V.

The former magneta GmbH & Co. KG has been part of the Kendrion Group since 2010. Now known as Kendrion (Aerzen) GmbH, this innovative company continues to develop and produce permanent magnet brakes for small motors, electromagnetic clutches and brakes at its site in Aerzen, along with magnetic particle clutches and brakes.

Kendrion – We magnetise the world!

www.kendrion-ids.com



About the Classic Line

The Classic Line is comprised of DC operated spring-applied single-disc and multiple-disc brakes whose sturdy design and variable connection features make it ideally suited for the most

demanding applications. Electromagnetic spring-applied brakes generate the braking torque when voltage is removed and the electromagnetic force is neutralised.

Versions

77 600..A00

torque range 4 - 240 Nm
DC
adjustable torque
single-disc brake (service brake)

77 600..A15

torque range 7.5 - 360 Nm
DC
adjustable torque
single-disc brake (holding brake)

77 100..A00

torque range 17 - 800 Nm
DC
adjustable torque
multiple-disc brake
built-in bracing springs for vertical operation

Upon request, the brake can be supplied with variable connection features (e.g. flying leads, connecting terminal or connection box with built-in rectifier).

Applications

DC motors

Handling technology

Lifting and materials handling technology

Crane construction

Paper-making and printing machines...

Data sheets – General information

The Operating Instructions must be strictly observed during the set-up of the machine (e.g. motor) and during the start-up, operation and maintenance of the brakes. The state-of-the-art brakes have been designed, built and tested in accordance with the requirements of DIN VDE 0580 concerning electromagnetic devices and components. Additional information on technical specifications given in the data sheets is included in the operating instructions.



Spring-applied single-disc brake DC

Versions	77 600..A00 - single-disc brake (service brake)
Standard rated voltages	24 V, 102 V, 178 V DC 230 V, 400 V AC
Protection	IP 54 IP 55 (when installed under motor fan hood)
Thermal class	F
Rated torques	4 - 240 Nm
Accessories (options)	hand release feature, mounting screws
Note	Specification subject to change without notice. The „General technical information“ and the „Operating instructions“ 77 600..A00 must be strictly observed.



Technical data

Size	Rated torque range (standard)	Max. reachable rated torque	Max. speed	Max. switching power		Max. switching energy (Z=1)	Rated power	Response times		Moment of inertia hub and friction disc	Weight
				attached	built in			Coupling time	Disconnection time		
	M ₂ [Nm]	M _{2 max} [Nm]	n _{max} [min ⁻¹]	P _{max} [kJ/h]	P _{max} [kJ/h]	W _{max} [kJ]	P _N [W]	t ₁ [ms]	t ₂ [ms]	J [kgcm ²]	m [kg]
10	4 - 8	9	5400	250	350	30	23	15	75	1.22	1.8
11	7 - 14	15	5000	320	480	41	26	30	90	1.75	2.9
13	16 - 32	35	4000	460	720	50	38	40	130	5	4.3
16	30 - 60	65	3500	570	930	58	60	85	145	14	8.6
19	65 - 130	140	3000	640	1090	65	75	100	185	37.5	13.4
24	120 - 240	260	3000	700	1190	80	108	180	220	87	26.5

Accessories

Size	Hand release feature	Mounting screws			
		Screw size	Rated torque	Material number	Screws per brake
10	76 14110B00940	ISO 4762 - M5 x 60 - 8.8	5.5 Nm	304 028	3
11	76 14111B00940	ISO 4762 - M5 x 70 - 8.8	5.5 Nm	304 030	3
13	76 14113B00940	ISO 4762 - M5 x 85 - 8.8	5.5 Nm	304 035	6
16	76 14116B00940	ISO 4762 - M6 x 100 - 8.8	9.5 Nm	304 060	6
19	76 14119B00940	ISO 4762 - M6 x 110 - 8.8	9.5 Nm	304 061	6
24	76 14124B00940	ISO 4762 - M8 x 130 - 8.8	22 Nm	304 088	6

Dimensions [mm]

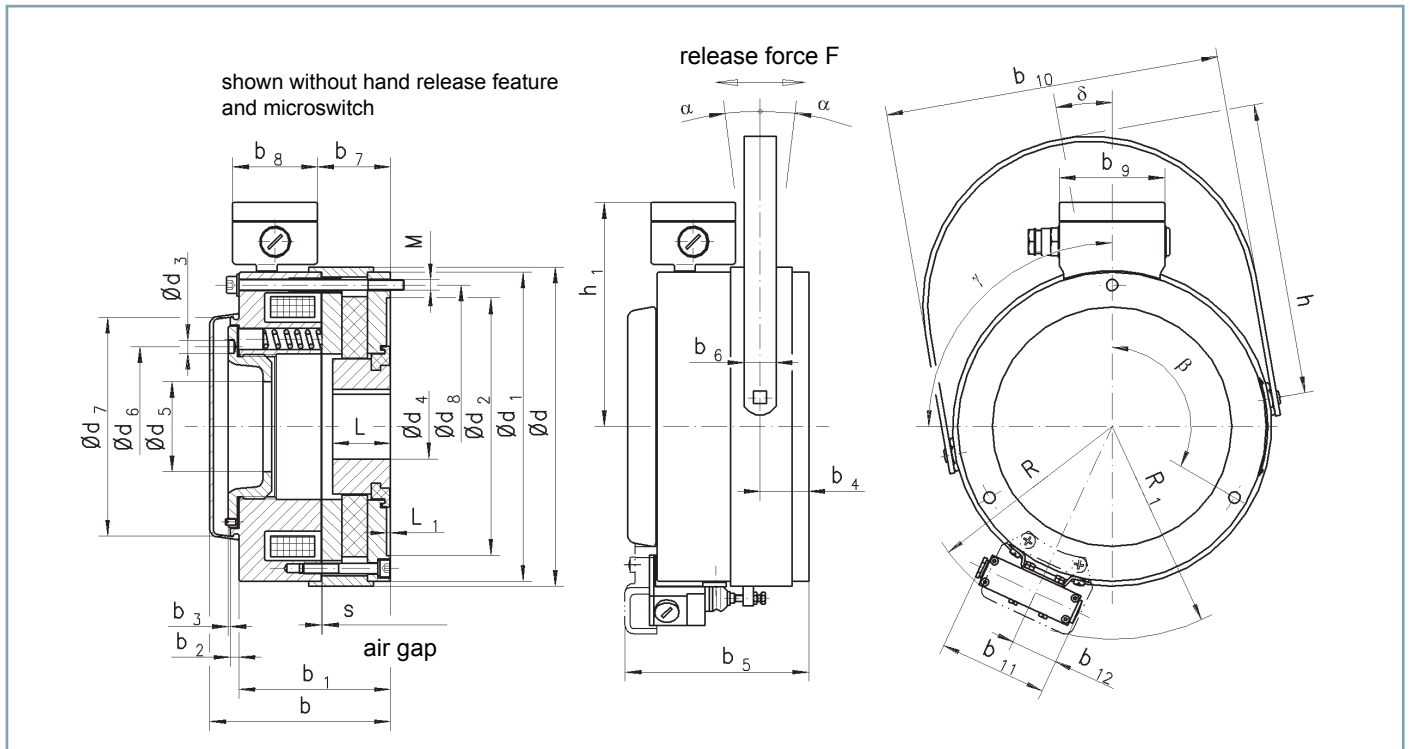

Size	d	d ₁	d ₂ (H9)	d ₃	d ₄ (H7)	d ₅	d ₆	d ₇ (j7)	d ₈	b ca.	b ₁	b ₂	b ₃	b ₄	b ₅	b ₆	b ₇	b ₈
10	105	100	75	5.1	10 ¹⁾ / 22 ²⁾	30	75	70	88	66	50	5	2-3.3	17.9	-	16	13	66
11	120	115	90	5.1	12 ¹⁾ / 22 ²⁾	30	96	72	100	74.5	58.5	5	3.6-6.2	19.4	-	20	8.5	66
13	140	135	110	6.1	16 ¹⁾ / 38 ²⁾	54	104	93	120	88.5	72.5	5	3-4.7	22.2	-	20	22.5	66
16	175	165	140	7.1	20 ¹⁾ / 45 ²⁾	67	124	125	150	106	87.8	5	4.7-8.6	23.7	113.5	20	38.5	66
19	200	190	160	7.1	25 ¹⁾ / 55 ²⁾	79	124	148	170	116	98.5	5	4.5-11	25.5	123.5	20	48.5	66
24	248	240	200	10.1	30 ¹⁾ / 70 ²⁾	90	150	170	220	140.5	117.5	7	2.7-5.6	34	142.5	25	57.5	66

Size	b ₉	b ₁₀	b ₁₁	b ₁₂	h	h ₁	R	R ₁	L	L ₁	s	s _{max} ³⁾	M	F[N] ⁴⁾	α	β	γ	δ
10	82	125.5	84	36.4	118	104	-	-	20.5	2.5	0.25 ^{+0.2}	0.65	3xM5	4	20°	3x120°	56°	180°
11	82	140.5	84	36.4	146	111.5	-	-	20.5	2.5	0.25 ^{+0.2}	0.65	3xM5	7	20°	3x120°	90°	0°
13	82	162.5	84	36.4	161	121.5	111	-	24	2.5	0.3 ^{+0.2}	0.75	6xM5	20	20°	6x60°	90°	10°
16	82	198	84	36.4	203	136.5	125	130	26.5	2.5	0.3 ^{+0.2}	0.85	6xM6	60	18°	6x60°	90°	10°
19	82	223	84	36.4	224	149	137	142	30	3	0.3 ^{+0.2}	0.85	6xM6	70	19°	6x60°	90°	10°
24	82	272.5	84	36.4	269	174	161	165	45	3	0.35 ^{+0.25}	0.95	6xM8	110	17°	6x60°	90°	15°

¹⁾ Min. bore with keyway JS9 as per DIN 6885, sheet 1.

²⁾ Max. bore with keyway JS9 as per DIN 6885, sheet 1.

Supporting keyway over entire length. Shaft ISO fitting k6. (¹⁾, ²⁾)

³⁾ Max. air gap referred to max. rated torque (standard).

⁴⁾ Release force F (approx.) referred to max. rated torque (standard).

Spring-applied single-disc brake DC

Versions	77 600..A15 - single-disc brake (holding brake)
Standard rated voltages	24 V, 102 V, 178 V DC 230 V, 400 V AC
Protection	IP 54 IP 55 (when installed under motor fan hood)
Thermal class	F
Rated torques	7.5 - 360 Nm
Accessories (options)	hand release feature, mounting screws
Note	Specification subject to change without notice. The „General technical information“ and the „Operating instructions“ 77 600..A15 must be strictly observed.



Technical data

Size	Transmissible torque range (standard)	Max. reachable transmissible torque	Max. speed	Max. switching power		Max. switching energy (Z=1)	Rated power	Response times		Moment of inertia hub and friction disc	Weight
				attached	built in			Coupling time	Disconnection time		
	M_4 [Nm]	$M_{4 \max}$ [Nm]	n_{\max} [min ⁻¹]	P_{\max} [kJ/h]	P_{\max} [kJ/h]	W_{\max} [kJ]	P_N [W]	t_1 [ms]	t_2 [ms]	J [kgcm ²]	m [kg]
10	7.5 - 15	15	5400	90	190	30	68	15	45	1.22	1.8
11	15 - 25	25	5000	125	285	41	79	20	60	1.75	2.9
13	35 - 50	55	4000	150	410	50	130	30	80	5	4.3
16	50 - 100	110	3500	175	535	58	155	50	120	14	8.6
19	120 - 200	200	3000	195	645	65	215	65	155	37.5	13.4
24	180 - 360	360	3000	240	730	80	167	110	205	87	26.5

Accessories

Size	Hand release feature	Mounting screws			
		Screw size	Rated torque	Material number	Screws per brake
10	76 14110B00940	ISO 4762 - M5 x 60 - 8.8	5.5 Nm	304 028	3
11	76 14111B00940	ISO 4762 - M5 x 70 - 8.8	5.5 Nm	304 030	3
13	76 14113B00940	ISO 4762 - M5 x 85 - 8.8	5.5 Nm	304 035	6
16	76 14116B00940	ISO 4762 - M6 x 100 - 8.8	9.5 Nm	304 060	6
19	76 14119B00940	ISO 4762 - M6 x 110 - 8.8	9.5 Nm	304 061	6
24	76 14124B00940	ISO 4762 - M8 x 130 - 8.8	22 Nm	304 088	6

Dimensions [mm]

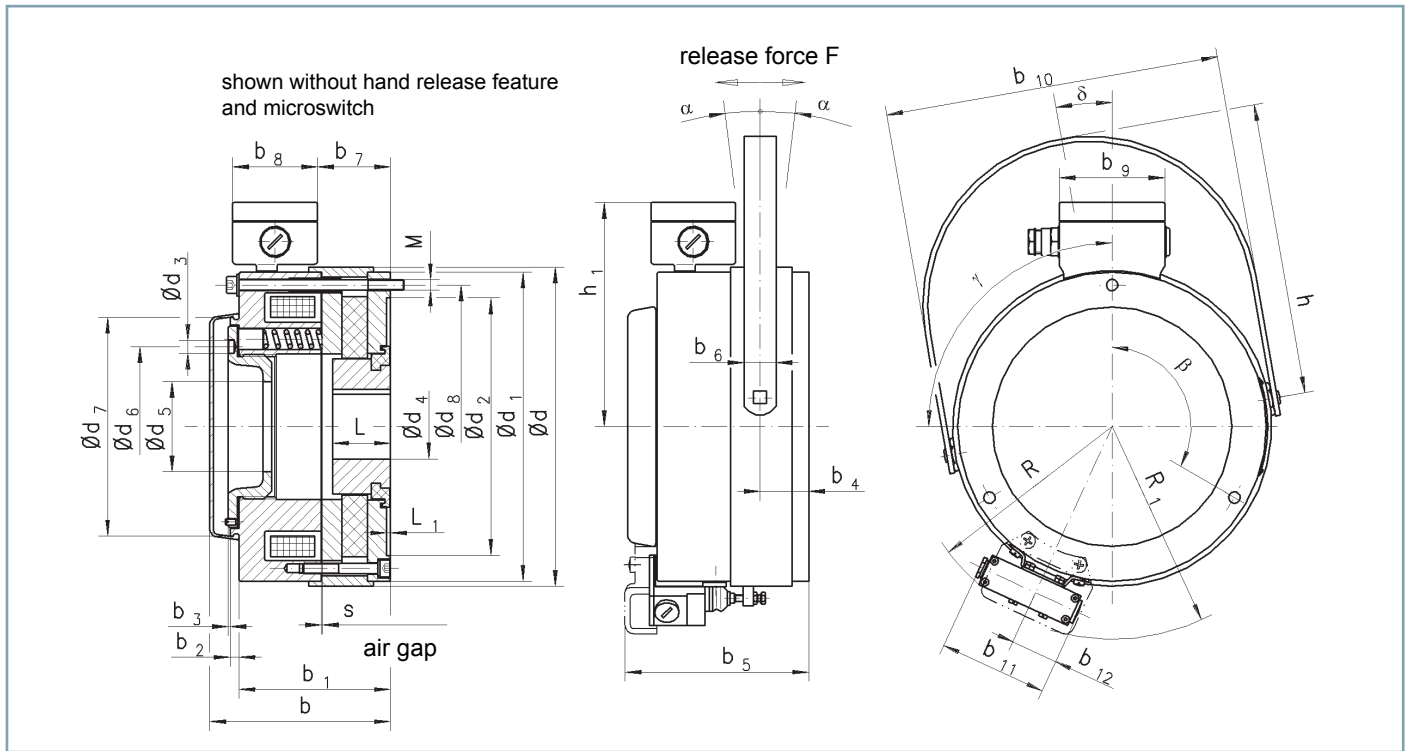

Size	d	d ₁	d ₂ (H9)	d ₃	d ₄ (H7)	d ₅	d ₆	d ₇ (j7)	d ₈	b	b ₁ ca.	b ₂	b ₃	b ₄	b ₅	b ₆	b ₇	b ₈
10	105	100	75	5.1	10 ¹⁾ / 22 ²⁾	30	75	70	88	66	50	5	1.9-3.9	17.9	-	16	13	66
11	120	115	90	5.1	12 ¹⁾ / 22 ²⁾	30	96	72	100	74.5	58.5	5	4.9-7	19.4	-	20	8.5	66
13	140	135	110	6.1	16 ¹⁾ / 38 ²⁾	54	104	93	120	88.5	72.5	5	4-5.5	22.2	-	20	22.5	66
16	175	165	140	7.1	20 ¹⁾ / 45 ²⁾	67	124	125	150	106	87.8	5	4.6-7.9	23.7	113.5	20	38.5	66
19	200	190	160	7.1	25 ¹⁾ / 55 ²⁾	79	124	148	170	116	98.5	5	3.7-9.6	25.5	123.5	20	48.5	66
24	248	240	200	10.1	30 ¹⁾ / 70 ²⁾	90	150	170	220	140.5	117.5	7	3.1-5.2	34	142.5	25	57.5	66

Size	b ₉	b ₁₀	b ₁₁	b ₁₂	h	h ₁	R	R ₁	L	L ₁	s	s _{max} ³⁾	M	F[N] ⁴⁾	α	β	γ	δ
10	82	125.5	84	36.4	118	104	-	-	20.5	2.5	0.28 ^{+0.2}	0.65	3xM5	8	20°	3x120°	56°	180°
11	82	140.5	84	36.4	146	111.5	-	-	20.5	2.5	0.28 ^{+0.2}	0.75	3xM5	13	20°	3x120°	90°	0°
13	82	162.5	84	36.4	161	121.5	111	-	24	2.5	0.33 ^{+0.2}	0.85	6xM5	32	20°	6x60°	90°	10°
16	82	198	84	36.4	203	136.5	125	130	26.5	2.5	0.35 ^{+0.2}	0.95	6xM6	100	18°	6x60°	90°	10°
19	82	223	84	36.4	224	149	137	142	30	3	0.4 ^{+0.2}	1.05	6xM6	110	19°	6x60°	90°	10°
24	82	272.5	84	36.4	269	174	161	165	45	3	0.4 ^{+0.25}	1.1	6xM8	165	17°	6x60°	90°	15°

¹⁾ Min. bore with keyway JS9 as per DIN 6885, sheet 1.

²⁾ Max. bore with keyway JS9 as per DIN 6885, sheet 1.

Supporting keyway over entire length. Shaft ISO fitting k6. (¹⁾, ²⁾)

³⁾ Max. air gap referred to max. transmissible torque (standard).

⁴⁾ Release force F (approx.) referred to max. transmissible torque (standard).

Spring-applied multiple-disc brake DC

Versions	77 100..A00
Standard rated voltages	24 V, 102 V, 178 V DC 230 V, 400 V AC
Protection	IP 54 IP 55 (when installed under motor fan hood)
Thermal class	F
Rated torques	17 - 800 Nm
Accessories (options)	hand release feature, mounting screws
Note	Specification subject to change without notice. The „General technical information“ and the „Operating instructions“ 77 100..A00 must be strictly observed.



Technical data

Size	Rated torque range (standard)	Max. reachable rated torque	Residual torque	Max. speed	Max. switching power		Max. switching energy (Z=1)	Rated power	Response times		Moment of inertia hub and friction disc	Weight
					attached	built in			Coupling time	Disconnection time		
					P_{max} [kJ/h]	P_{max} [kJ/h]						
13	17 - 25	27	0.05	4500	460	720	25	38	50	160	6.25	5.4
16	25 - 50	55	0.1	3800	570	930	42	60	80	200	20	10.2
19	50 - 100	110	0.2	3200	640	1090	67	75	100	270	40	14.8
24	100 - 200	220	0.5	3000	700	1190	113	109	200	330	95	31.1
25	150 - 300	330	0.7	3000	740	1210	125	109	250	350	135	32.6
29	200 - 400	440	1	3000	1000	1700	180	185	300	480	250	58.3
33	400 - 800	880	2	2500	1300	1980	235	230	450	600	650	93.4

Accessories

Size	Hand release feature	Mounting screws			
		Screw size	Rated torque	Material number	Screws per brake
13	71 10113E00940	ISO 4762 - M5 x 85 - 8.8	4 Nm	304 035	6
16	71 10116E00940	ISO 4762 - M6 x 100 - 8.8	8 Nm	304 060	6
19	71 10119E00940	ISO 4762 - M6 x 120 - 8.8	8 Nm	304 062	6
24	71 10124E00940	ISO 4762 - M8 x 130 - 8.8	12 Nm	304 088	6
25	71 10124E00940	ISO 4762 - M8 x 140 - 8.8	12 Nm	304 090	6
29	71 10129E00940	ISO 4762 - M10 x 170 - 8.8	18 Nm	304 123	6
33	71 10133E00940	ISO 4762 - M12 x 200 - 8.8	28 Nm	304 150	6

Dimensions [mm]

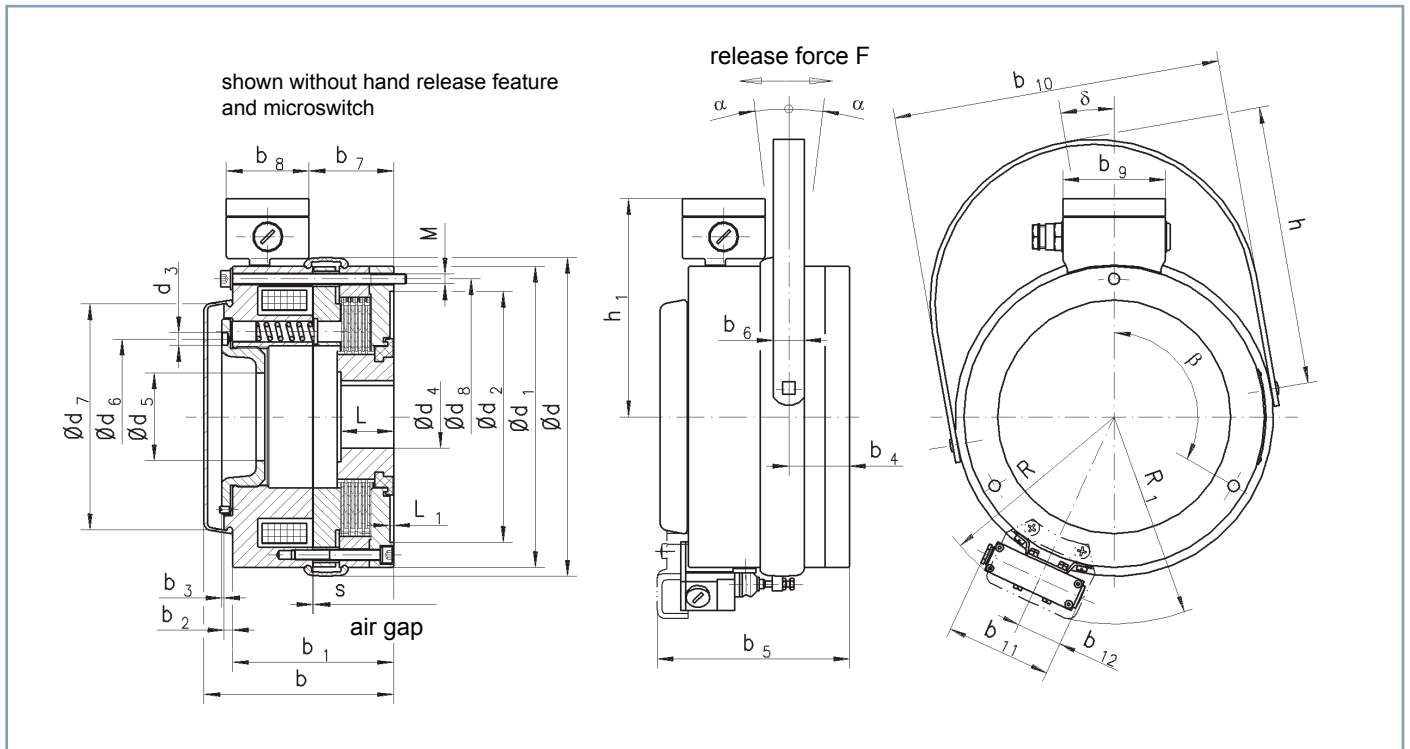

Size	d	d ₁	d ₂ (H9)	d ₃	d ₄ (H7)	d ₅	d ₆	d ₇ (j7)	d ₈	b ca.	b ₁	b ₂	b ₃	b ₄	b ₅	b ₆	b ₇	b ₈
13	146	135	110	6.1	12 ¹⁾ / 35 ²⁾	54	75	93	120	90	73.5	5	3.0-4.6	27.5	-	20	23.5	66
16	178	165	140	7.1	20 ¹⁾ / 45 ²⁾	67	96	125	150	108	90	5	2.4-4.6	32	115	20	40	66
19	204	190	160	7.1	25 ¹⁾ / 55 ²⁾	79	104	148	170	120	102	5	3.8-5.6	35.5	127	20	52	66
24	258	240	200	10.1	30 ¹⁾ / 75 ²⁾	90	124	170	220	143	120	7	2.8-5.2	39.5	145	25	59	66
25	258	240	200	10.1	30 ¹⁾ / 75 ²⁾	90	124	170	220	151	128	7	3.1-5.0	48	153	25	67	66
29	315	290	240	10.1	35 ¹⁾ / 85 ²⁾	100	150	210 ¹⁾	267	177	155	8	1.4-3.4	53	-	30	89	66
33	356	330	275	10.1	40 ¹⁾ / 95 ²⁾	115	165	225 ¹⁾	300	202	179	8	1.9-4.1	60.5	-	30	112	66

Size	b ₉	b ₁₀	b ₁₁	b ₁₂	h	h ₁	R	R ₁	L	L ₁	s	s _{max} ³⁾	M	F[N] ⁴⁾	α	β	δ
13	82	155	84	36.5	161	121.5	111	-	25	2.5	0.5 ^{+0.2}	1	6xM5	15	16°	6x60°	10°
16	82	187	84	36.5	203	136.5	125	130	28	2.5	0.6 ^{+0.2}	1.7	6xM6	40	15°	6x60°	10°
19	82	216	84	36.5	224	149	137	142	31	3	0.6 ^{+0.3}	1.7	6xM6	50	16°	6x60°	10°
24	82	266	84	36.5	269	174	161	165	45	3	0.7 ^{+0.3}	1.8	6xM8	55	20°	6x60°	10°
25	82	266	84	36.5	269	174	161	165	45	3	0.9 ^{+0.3}	1.8	6xM8	55	20°	6x60°	10°
29	82	316	84	36.5	328	199	186	-	52	5	1.1 ^{+0.3}	2.3	6xM10	90	21°	6x60°	10°
33	82	358	84	36.5	377	219	205	-	58	5	1.1 ^{+0.3}	2.5	6xM12	180	22°	6x60°	10°

¹⁾ Min. bore with keyway JS9 as per DIN 6885, sheet 1.

²⁾ Max. bore with keyway JS9 as per DIN 6885, sheet 1.

Supporting keyway over entire length. Shaft ISO fitting k6. (¹⁾, ²⁾)

³⁾ Max. air gap referred to max. transmissible torque (standard).

⁴⁾ Release force F (approx.) referred to max. transmissible torque (standard).

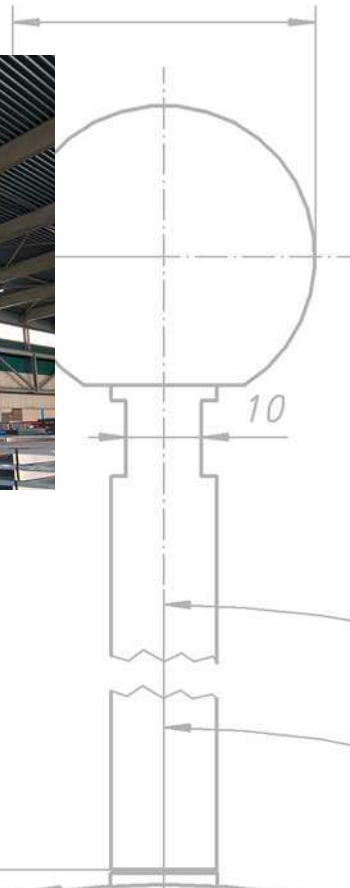

INDIVIDUAL CUSTOMER SOLUTIONS

Customer-Specific Applications

- Based on existing standard platforms
- From minor to major adaptations
- According to specific customer requirements

Customized Solutions and Applications

- Comprehensive design of new devices according to individual customer requirements

Complete Solutions

- Based on the individual solutions mentioned above
- Our brakes and clutches in combination with our electronic accessories

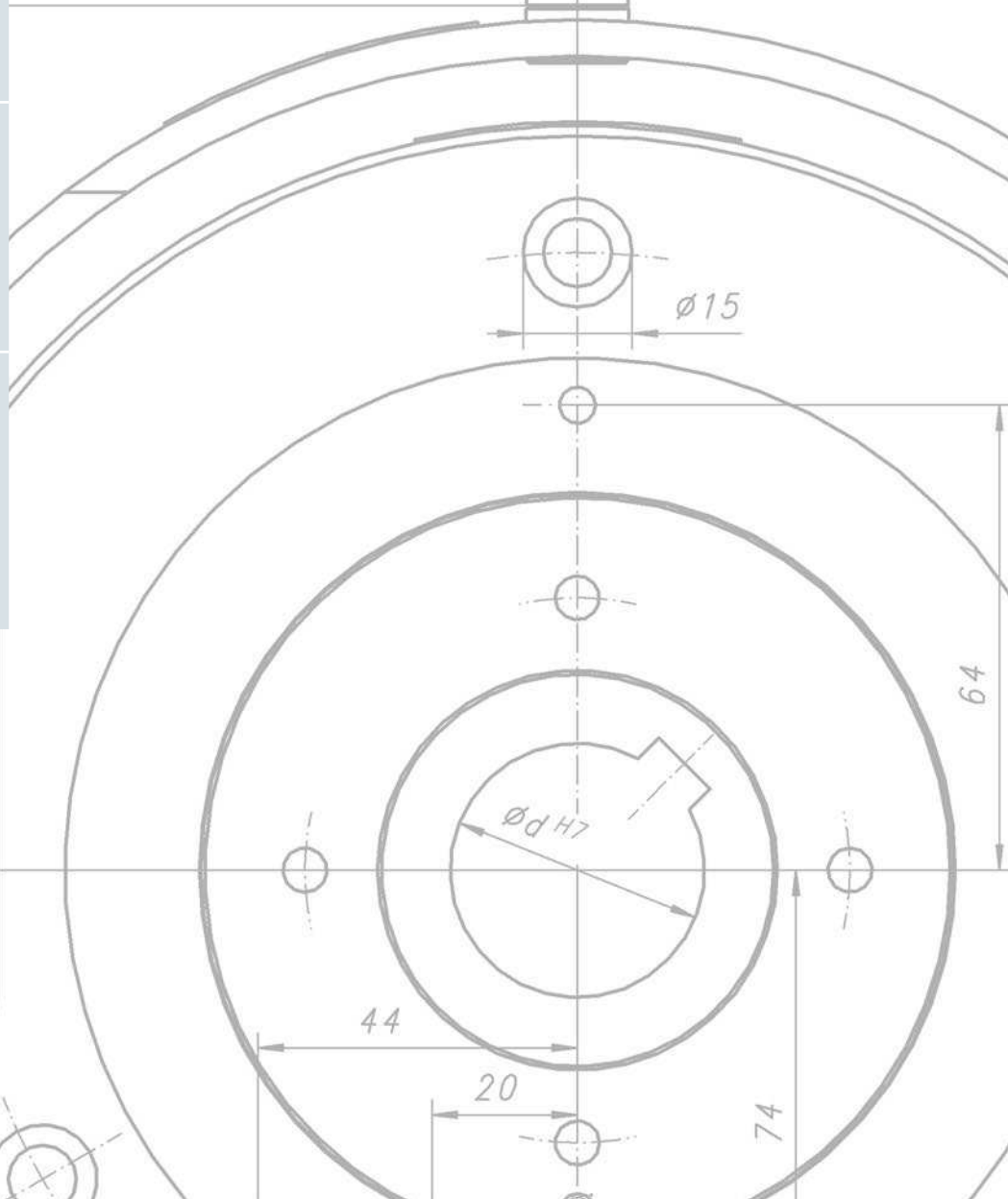



WE MAGNETISE THE WORLD

Kendrion (Villingen) GmbH
Wilhelm-Binder-Strasse 4-6
78048 Villingen-Schwenningen
Germany
Tel: +49 7721 877-0
Fax: +49 7721 877-1462
sales-ids@kendrion.com
www.kendrion.com