



32 67124A00

Hybrid rectifier for bridge and half-wave rectified DC voltage with fast turn-off through voltage detection

The rectifier with built-in voltage sensor for fast turn-off is designed for the operation of electromagnetic devices. The rectifier with bridge circuit delivers both half-wave and bridge rectified DC output voltage. The built-in voltage sensor ensures that the DC side output is interrupted when AC input voltage is removed. The turn-off voltage generated by the inductive load is limited. The rectifier is generally suitable for connection in parallel with AC motors. However, a separate power supply is required for the rectifier in the presence of driving loads, high moments of inertia or in case of frequency converter operation of the motor.

Technical specifications

Rectifier operating principle		Time-controlled changeover from bridge rectification to half-wave rectification				
DC side switching		internal, with voltage detection				
Ambient temperature		(°C)	-25 ... 85	derating for load current: see diagram		
Transient overload capacity of current detection		($f(I_{Mn})$)	$-7 * I_{Mn}$			
Turn-off delay		(ms)	25ms			
Turn-off voltage		(V)	approx. 350V	at $I = 0.7ADC$		
Maximum permitted energy absorption of switching voltage limitation		(J)	28	for 2ms		
Type	Rated input voltage U_1 (tol.: $\pm 10\%$) (40 – 60 Hz) (VAC)	Output voltage BD1(1+) and BD2	Output voltage BD1(2+) and BD2	Max. output current I_{OE} / I_H (ADC)	Housing W x H x D (mm)	Connections
32 67124A00	220 - 500	$0.445 * U_1$	$0.89 * U_1$	1.2 / 1.2	43 x 55.5 x 33	5 stranded wires, 1.5mm ² , fine-wire/ to UL 1015/TEW or UL10086(AWG 14)

CE

EMC Directive 2004/108/EEC:

Compliance with the following standards is confirmed:
 EN 50081-2 (Emission):
 EN 55011 (VDE 0875, part 11, 1992)
 Group 1, Class A conducted interference
 Group 1, Class B radiated interference
 EN 61000-6-2 (Immunity):
 EN 61000-4-3 (1997) severity level 3
 EN 61000-4-4 (1996) severity level 3
 EN 61000-4-5 (1996) severity level 3

Low Voltage Directive 2006/95/EEC:

Compliance with the following standards is confirmed:
 HD 625.1S1 (1996), (VDE 0110) insulation coordination, EN
 60529 (1991) IP 54 external mounting

Machinery Directive 2006/42/EC: These products are considered components in the sense of Machinery Directive 2006/42/EC and must not be put into service until the machinery in which they are incorporated has been declared in conformity with the provisions of the EC Directives.

ROHS

The specified products comply with Directive 2002/95/EC (ROHS).

Connection example: Brake motor application

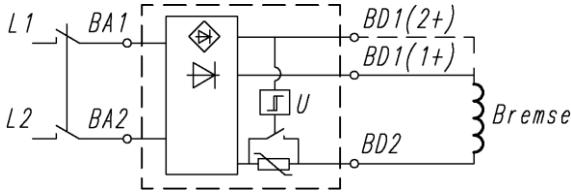

Dimensions (mm)

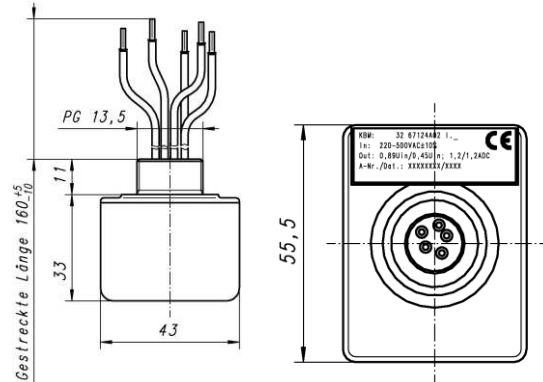

Permitted switching frequency

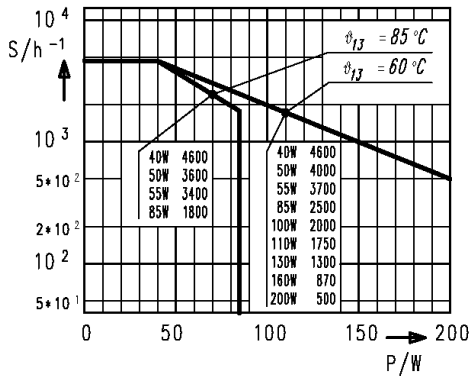

Permitted current load at ambient temperature

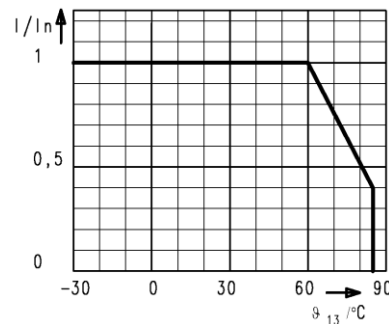

Protection:
IP 67 to EN 60529

**Subject to
change without
notice.**

Connection and operation

When the rectifier is used for brake motor applications and connected in parallel with the motor terminals, the open-circuit voltage generated as the motor runs down may cause a substantial delay in brake engagement because the input voltage does not fall below the switching threshold of the voltage sensor. This phenomenon may occur with active mechanical loads in particular. In this case, a rectifier with current detection or separate AC side rectifier switching with an additional switching contact or current relay may be preferable.

Attention!

Switching operations must take place in such a way that the interval time between power off and power on is at least as long as the overexcitation time specified for the rectifier. In addition to this, the mean power of the load generated as a result of the switching operation must not exceed its rated power to avoid thermal overloading. Prolonged operation below the permitted operating voltage is not allowed. The load must be connected to the bridge or half wave DC voltage output. Simultaneous operation of loads connected to both outputs is not envisaged. The output not in use is live and must be insulated to avoid hazards.

Rec. mounting

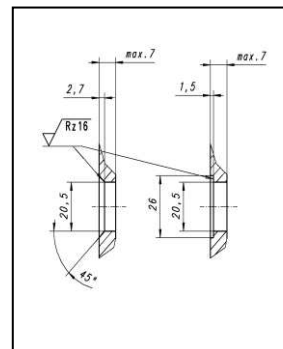

Connections

Colour	Identification to EN60034-8
Brown	BA1 = ACin
Brown	BA2 = ACin
Red	BD1(1+) = L1 +
Green	BD1(2+) = L2 +
Black	BD2 = L -

Kendrion (Villingen) GmbH
Wilhelm-Binder-Straße 4-6
78048 Villingen-Schwenningen
Germany

Phone +49 7721 877 1417
Fax +49 7721 877 1462
E-Mail sales-ids@kendrion.com
www.kendrion.com