

Part No. 501 11731



20 ... 40mm



- Reliable detection of splice on paper web or plastic web
- Sheet speeds up to 1000m/min
- Automatic adaptation to the medium
- High acoustic power (guaranteeing reliable functionality even for thick materials)
- Ultrasonic sensor in the M18 round-sleeve housing
- Plug connection
- Short-circuit proof PNP transistor outputs operating-state indication by means of LEDs
- Sensors have a very short construction (can thus also be used in applications with limited available space)
- Paper tear detection (...4.5)



Accessories:

(available separately)

- M12 connectors (KD ...)
- Ready-made cables (KB ...) 5-pin: KB-095-5000-5A

Dimensioned drawing

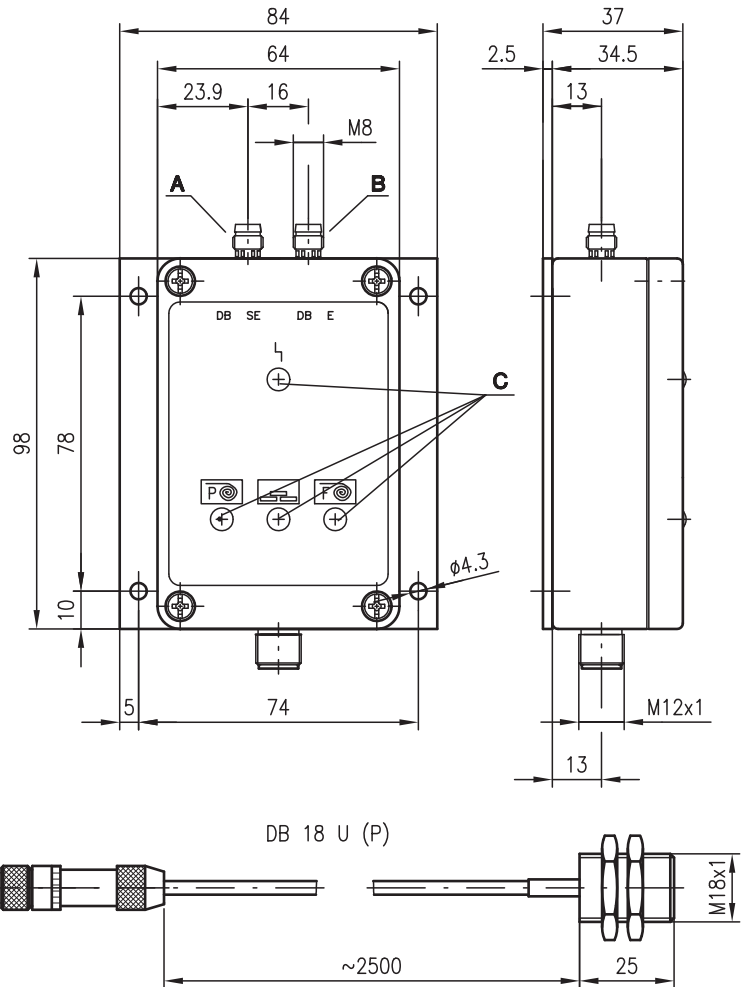

- A** Transmitter DB 18 U (P)
- B** Receiver DB 18 U (P)
- C** Indicator diodes

Electrical connection

VSU 12/4.4

10-30V DC +	1	br/BN
Level under Limit	2	ws/WH
GND	3	bl/BU
Tape	4	sw/BK
Paper/Foil	5	gr/GR

VSU12/4.5

10-30V DC +	1	br/BN
web material	2	ws/WH
GND	3	bl/BU
Tape	4	sw/BK
Paper/Foil	5	gr/GR

We reserve the right to make changes • VSU_12_gb.fm

Specifications

Sensor data

Operating range (recommended)	DB 18 UP	VSU 12/4.4.../4.5
Operating range limit	25mm	
Converter frequency	20 ... 40mm	
Sound cone	200kHz ± 2%	
	approx. 12°	

Timing

Web speed		max. 1000m/min min. ≥ 6mm/s (with 30mm splice width) path clear/ inserted medium < 5s ≤ 100ms 0 ... 200ms, adjustable
Recovery-time constant (LED A flashes briefly)		
Delay before start-up		
Pulse stretching		

Electrical data

Operating voltage U_B		10 ... 30VDC (incl. residual ripple) ≤ 15% of U_B ≤ 75mA
Residual ripple		
Bias current		

Outputs

Tape		PNP transistor output forced tripping of transistor when splice detected
Function		PNP transistor output forced tripping of transistor when material not detectable
Level under limit		
Function		

VSU 12/4.5

Web material (paper tear)		PNP transistor output forced tripping of transistor when material present between the sensors ≥ ($U_B - 2V$) / ≤ 2V max. 200mA per output
Function		
Signal voltage high/low		
Output current		

Indicators

VSU 12/4.4

LED B green		foil selected
LED D green		paper selected
LED C yellow		splice detected
LED A red flashing		material not detectable

VSU 12/4.5

LED A red flashing		material not detectable
LED A yellow		paper tear

Mechanical data

Housing	nickel-faced brass	aluminum, powder coated black
Weight	30g	400g
Connection type	M8 connector, 3-pin, with 2m cable	M12 connector, 5-pin

Environmental data

Ambient temp. (operation/storage)		0°C ... +60°C / -40°C ... +70°C
Protective circuit ¹⁾		1,2,3
VDE safety class		III
Protection class		IP 65
Standards applied		EN 60947-5-2

Options

Commutation input Paper/Foil ²⁾

Paper mode	0V or not connected
Foil mode	≥ 8V

1) 1=transient protection, 2=polarity reversal protection, 3=short circuit protection
2) Switch **S1** must be in position **0** "Paper"

Tables

Diagrams

Splice width in dependence of web speed

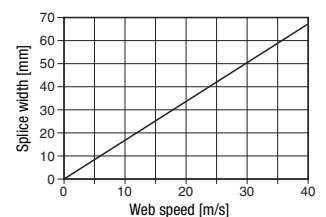

Note

Order guide

	Designation	Part No.
Sensor pair	DB 18 UP.1-25, 2500	501 08998
Amplifier	VSU 12/4.4	501 04022
	VSU 12/4.5	501 04139

VSU 12

Technical description

General

The ultrasonic system for splice detection consists of a VSU 12/4... evaluation amplifier and a DB 18 UP ultrasonic sensor pair. It mainly detects splices on paper, plastic or metal web used on roll machines.

Mounting

Transmitter and receiver (DB 18 UP) have the same construction and are to be mounted at an angle of $65^\circ (\pm 2^\circ)$ relative to the sheet.

The distance between transmitter and receiver should be 25mm (± 5 mm).

Exact alignment ($\pm 1^\circ$) must be ensured. Alignment which is not in line with the axis results in a reduction of the working range. The material to be scanned must be located approx. 8 ... 10mm above the transmitter.

The pitch of the sensors should be parallel to the tape or, as the case may be, splices.

Function

The evaluation unit can be operated in two different modes.

a) Parameter switch S1 in position "0" (paper)

The sheet is either paper or cardboard.

b) Parameter switch S1 in position "1" (foil)

The sheet is either plastic or metalised foil.
The amplifier has a higher sensitivity.

The changeover from "paper" to "foil" can also be performed via PIN 5 "Paper/Foil". Low-level on connection 5 means "paper", high-level (≥ 8 V) on connection 5 means "foil". The parameter switch **S1** must be in position **0** "paper" in order to use this feature (state on delivery).

Adjusting the sensitivity (P2)

Inhomogeneities in the web material may lead to erroneous switching in the detection of glued seams. These faults may generate signals even if there is no glued seam. By lowering the sensitivity via the potentiometer **P2** (turn left), this erroneous switching may be alleviated. Full right turn position on **P2** corresponds to maximum sensitivity (factory setting).

Operation VSU 12/4.4

The VSU 12/4.4 evaluation unit automatically adapts to the acoustic transmissivity of the medium. As soon as a splice is detected, the "splice detected" output (tape) is triggered. The duration of the output signal can be set via the potentiometer (pulse stretching) **P1**. The maximum time which can be set is 200ms. A detected splice is indicated on LED **C**.

If the level is not sufficient for reliable detection, the "Material not detectable" output (Level under Limit) is triggered. This is also signalled via the red flashing LED **A**.

Operation VSU 12/4.5

The VSU 12/4.5 evaluation unit automatically adapts to the acoustic transmissivity of the medium. As soon as a splice is detected, the "splice detected" output (tape) is triggered. The duration of the output signal can be set via the potentiometer (pulse stretching) **P1**. The maximum time which can be set is 200ms. A detected splice is indicated on LED **C**.

If the level is not adequate for reliable detection, this is indicated by the red, flashing LED **A**. As soon as the system detects a paper tear or if no material is present between the sensors, this is indicated at PIN 2 via the PNP output.

Controls and indicators

Display

(see Specifications)

Adjustment

(see Specifications)

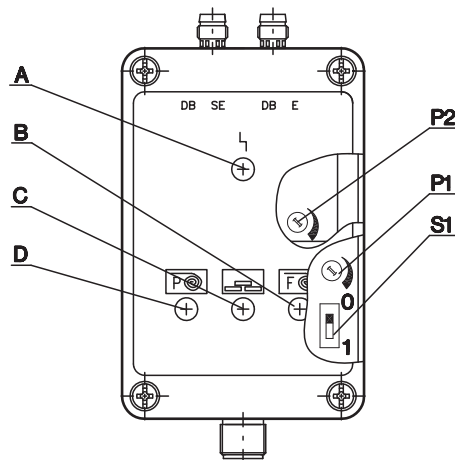

- A** Red LED
- B** Green LED
- C** Yellow LED
- D** Green LED
- P1** Potentiometer
0 ... 200ms pulse stretching
- P2** Potentiometer
sensitivity adjustment
- S1** Foil/Paper switch
0 = paper
1 = foil

Mounting and notes

Note

- When aligning the sender and receiver, the best possible alignment must be ensured.
- For proper function, the sensors must be positioned at an angle of **F** = 65° (± 2°) relative to the web.

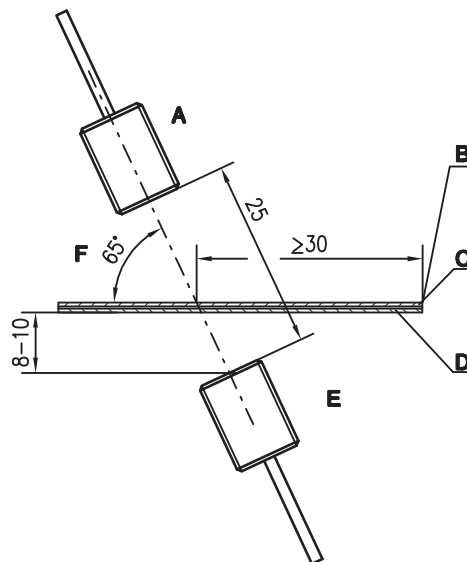

- A** Receiver
- B** Outer edge
- C** Tape min. 15mm wide
- D** Paper or foil web
- E** Transmitter
- F** Pitch relative to the direction of travel

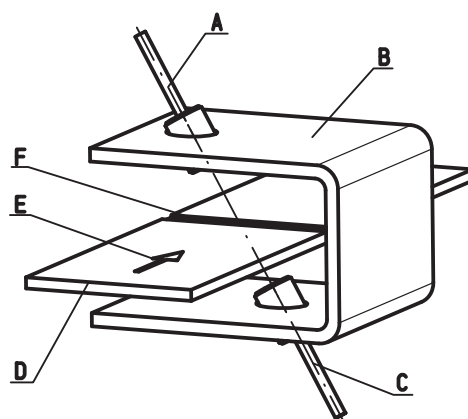

- A** Receiver
- B** Holder
- C** Transmitter
- D** Paper or foil web
- E** Direction of travel
- F** Splice