

Leuze electronic

the sensor people

SMART
SENSOR
BUSINESS

MSI-TRM

Safety Relays



EN 2015/04 - 50128273
We reserve the right to
make technical changes

SAFE IMPLEMENTATION AND OPERATION
Original operating instructions

© 2015

Leuze electronic GmbH + Co. KG

In der Braike 1

D-73277 Owen / Germany

Phone: +49 7021 573-0

Fax: +49 7021 573-199

<http://www.leuze.com>

info@leuze.de

1	About this document	5
1.1	Used symbols and signal words	5
1.2	Checklists	6
2	Safety	7
2.1	Approved purpose and foreseeable improper operation	7
2.1.1	Intended use	7
2.1.2	Foreseeable misuse	8
2.2	Competent persons	8
2.3	Responsibility for safety	8
2.4	Disclaimer	9
3	Device description	10
3.1	Device connection	11
3.2	Display elements	11
3.3	Error display	12
4	Functions	14
4.1	Operating mode 1 AOPD	14
4.2	Operating mode 2 AOPDs	14
4.3	Operating mode ES	14
4.4	Operating mode SG	15
4.5	Testing with operating mode 1 AOPD and 2 AOPDs	15
4.6	Testing with operating mode ES and SG	15
4.7	Start/restart interlock and contactor monitoring (EDM)	15
4.8	Error state FAIL SAFE	16
4.8.1	Software reset	16
5	Applications	17
5.1	Access guarding	17
6	Mounting	19
6.1	Arrangement of the protective device	19
6.1.1	Calculating the safety distance	19
6.1.2	Multi-axis arrangement	20
6.1.3	Minimum distance to reflective surfaces	20
6.1.4	Checklist – mounting the protective sensor	22
7	Electrical connection	23
7.1	Terminal assignments	23
8	Starting up the device	34
8.1	Switching on	34
8.2	Start/restart	34
8.2.1	Unlocking start/restart interlock	34
9	Testing	35
9.1	Before the initial start-up and following modifications	35
9.1.1	Checklist – initial start-up	35
9.2	To be performed periodically by a competent person	37
9.3	To be performed daily by the operating personnel	37
9.3.1	Check list – daily or at change of shift	37

10	Maintenance	39
11	Troubleshooting	40
	11.1 What to do in case of error?	40
	11.2 Operating displays of the LEDs	40
12	Disposing	41
13	Service and support	42
14	Technical data	43
	14.1 General specifications	43
	14.2 Dimensions	44
15	Ordering information and accessories	46
16	Declaration of Conformity	47

1 About this document

1.1 Used symbols and signal words

Table 1.1: Warning symbols and signal words

	Symbol indicating dangers to persons
NOTICE	Signal word for property damage Indicates dangers that may result in property damage if the measures for danger avoidance are not followed.
CAUTION	Signal word for minor injury Indicates dangers that may result in minor injury if the measures for danger avoidance are not followed.
WARNING	Signal word for serious injury Indicates dangers that may result in severe or fatal injury if the measures for danger avoidance are not followed.
DANGER	Signal word for life-threatening danger Indicates dangers with which serious or fatal injury is imminent if the measures for danger avoidance are not followed.

Table 1.2: Other symbols



	Symbol for tips Text passages with this symbol provide you with further information.
	Symbols for action steps Text passages with this symbol instruct you to perform actions.

Table 1.3: Terms and abbreviations

AOPD	Active Optoelectronic Protective Device
EDM	External Device Monitoring
OSSD	Output Signal Switching Device
SSD	Secondary Switching Device
RES	Start/REStart interlock
PFH	Probability of a dangerous failure per hour Probability of dangerous Failure per Hour
MTTF	Mean time to dangerous failure Mean Time To Failure
PL	Performance Level
ES	Emergency Stop
SG	Safety Gate
Optical short-circuit	Short-circuit of one or more series-connected photoelectric sensors caused by optical signals

1.2 Checklists

The checklists (see chapter 9 "Testing") serve as a reference for the machine manufacturer or supplier. They replace neither testing of the complete machine or system prior to the initial start-up nor their periodic testing by a competent person. The checklists contain minimum testing requirements. Depending on the application, other tests may be necessary.

2 Safety

Before using the safety relay, a risk evaluation must be performed according to valid standards (e.g. EN ISO 14121, EN ISO 12100-1, EN ISO 13849-1, IEC 61508, EN 62061). The result of the risk assessment determines the required safety level of the safety relay (see table 14.1). For mounting, operating and testing, this document as well as all applicable national and international standards, regulations, rules and directives must be observed. Relevant and supplied documents must be observed and handed to the affected personnel.

↳ Before working with the safety relay, completely read and understand the documents applicable to your task.

In particular, the following national and international legal regulations apply for the start-up, technical inspections and work with safety relays:

- Machinery directive 2006/42/EC
- Low voltage directive 2006/95/EC
- Electromagnetic compatibility 2004/108/EC
- Use of work equipment directive 89/655/EEC supplemented by directive 95/63 EC
- OSHA 1910 Subpart 0
- Safety regulations
- Accident-prevention regulations and safety rules
- Industrial safety regulation and employment protection act
- Device Safety Act



For safety-related information you may also contact the local authorities (e.g., industrial inspectorate, employer's liability insurance association, labor inspectorate, occupational safety and health authority).

2.1 Approved purpose and foreseeable improper operation

DANGER
Electrically live systems pose a risk of electric shock!
↳ During all conversions, maintenance work and inspections, make certain that the voltage supply is interrupted and protected against being restarted again.
↳ Only have work on the electrical system and electronics performed by a competent person.

2.1.1 Intended use

WARNING
A running machine may result in serious injury!
↳ Make certain that the safety relay is correctly connected and that the protective function of the protective device is ensured.
↳ Make certain that, during all conversions, maintenance work and inspections, the system is securely shut down and protected against being restarted.

Only if the safety relay is correctly connected and correctly started up is the protective function of the protective device ensured. To prevent misuse and resulting dangers, the following must be observed:

- These operating instructions are included in the documentation of the system on which the protective device is mounted and are available to the operating personnel at all times.
- The safety relay is used as follows:
 - as a safety monitoring device in combination with one or more protective sensors for safeguarding danger zones or points of operation on machines and systems.

- as a safety sequential device for 2-channel E-Stop and safety door monitoring.
- The safety relay must only be used after it has been selected in accordance with the respectively applicable instructions and relevant standards, rules and regulations regarding labor protection and safety at work, and after it has been installed, connected, checked and commissioned by a competent person.
- The safety relay must only be connected and commissioned in accordance with its specifications (technical data, environmental conditions, etc.).
- The “Reset” acknowledgment button for unlocking the start/restart interlock must be located outside of the danger zone.
- The entire danger zone must be visible from the installation site of the acknowledgment button.
- The safety relay must be selected so that its safety-related capability meets or exceeds the required Performance Level PL ascertained in the risk assessment (see table 14.1).
- The machine or system control must be electrically influenceable so that a switch command sent by the safety relay results in the immediate shutdown of the dangerous movement.
- The construction of the safety relay must not be altered. When manipulating the safety relay, the protective function is no longer guaranteed. Manipulating the safety relay also voids all warranty claims against the manufacturer of the safety relay.
- The safety relay must be tested by a qualified person at regular intervals, i.e. at least every 6 months or during regular maintenance of the machine.
- The safety relay must be exchanged after a maximum of 20 years. Repairs or the exchange of parts subject to wear and tear do not extend the service life.

2.1.2 Foreseeable misuse

Any use other than that defined under the “Approved purpose” or which goes beyond that use is considered improper use.

Alone, the safety relay is not a complete protective device. It is not suitable for use in the following cases:

- in explosive or easily flammable atmospheres.
- on machines or systems with long stopping times.

2.2 Competent persons

Prerequisites for competent persons:

- They have a suitable technical education.
- They know the rules and regulations for labor protection, safety at work and safety technology and can assess the safety of the machine.
- They know the instructions for the safety relay and the machine.
- They have been instructed by the responsible person on the mounting and operation of the machine and of the safety relay.

2.3 Responsibility for safety

Manufacturer and operating company must ensure that the machine and implemented safety relay function properly and that all affected persons are adequately informed and trained.

The type and content of all imparted information must not lead to unsafe actions by users.

The manufacturer of the machine is responsible for:

- Safe machine construction.
- Safe implementation of the safety relay.
- Imparting all relevant information to the operating company.
- Adhering to all regulations and directives for the safe starting-up of the machine.

The company operating the machine is responsible for:

- Instructing the operating personnel.
- Maintaining the safe operation of the machine.
- Adhering to all regulations and directives for labor protection and safety at work.
- Regular testing by competent persons.

2.4 Disclaimer

Leuze electronic GmbH + Co. KG is not liable in the following cases:

- Safety relay is not used as intended.
- Safety notices are not adhered to.
- Reasonably foreseeable misuse is not taken into account.
- Mounting and electrical connection are not properly performed.
- Proper function is not tested (see chapter 9 "Testing").
- Changes (e.g., constructional) are made to the safety relay.

3.1 Device connection

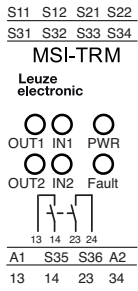

Figure 3.2: MSI-TRM

3.2 Display elements

The display elements of the safety relay simplify start-up and fault analysis.

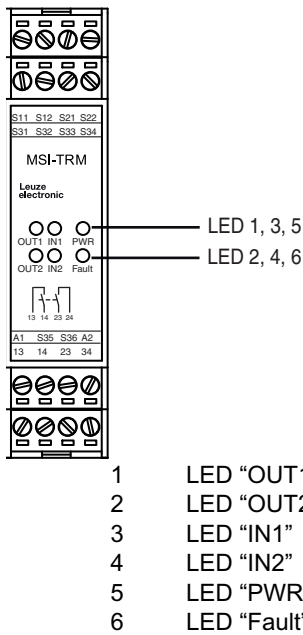

Figure 3.3: Display elements of the MSI-TRM

Table 3.1: Meaning of the LEDs

LED	Color	Description
OUT1	Green	Channel 1 relay actuated
OUT2	Green	Channel 2 relay actuated
OUT1 and OUT2	Flashing green	Optical short-circuit in the case of ESPE applications
IN1	Yellow	Input 1 active
IN2	Yellow	Input 2 active
IN1 and IN2	Flashing yellow	Single-channel switch-off – waiting for second channel (in the case of E-Stop/safety door application)

LED	Color	Description
PWR	Green	Power ON
PWR	Flashing green	Supply voltage not correct (see chapter 14.1 "General specifications")
Fault	Red	Internal or external fault (see chapter 3.3 "Error display")

3.3 Error display

Table 3.2: Error display via LEDs

LED indicators			Errors and possible causes	Remedial measures
Fault	IN1, IN2	OUT1, OUT2		
On	Flashing	Off	Start button / bridge is (with automatic, non-monitored start) not connected to S21	Disconnect device from power supply, check for wiring faults, replace device if defective
			Change of start condition during operation	
On	Off	Flashing alternately	Output S11/S21 short-circuit to GND	Disconnect device from power supply, check wiring, replace device if defective or check connected ESPE
			Output S11/S21 short-circuit to VCC	
			Incorrect input signals, incorrect operating mode	
			Reaction time of ESPE is longer than 8.5 ms	
			Cross connection between S11 and S21 or S12 and S22	
On	Off	Flashing	Error during relay test – internal relay defective / fused together	Disconnect device from power supply, check connections at relay contacts, check max. output capability (see chapter 14.1 "General specifications"), replace device if defective

LED indicators			Errors and possible causes	Remedial measures
Fault	IN1, IN2	OUT1, OUT2		
On	Flashing alternately	Off	With E-Stop/protective door application: When switching on power supply, signals at S12 and S22 have different values	Disconnect device from power supply, check for wiring faults, replace device if defective or check connected ESPE
			Problems with detection of operating mode: Signal at S32 cannot be clearly allocated	
			Problems with detection of operating mode: Bridge / signal at S12 cannot be clearly allocated	
			Application - connection of ESPE: Bridge S21-S12 was removed during operation	
			Wiring at S32 was changed during operation or S32 has short-circuited to VCC/GND during operation	
On	Flashing alternately	Flashing alternately	Optical short-circuit existed during teach-in and was removed later	Disconnect device from power supply, check wiring and connected ESPE

4 Functions

After the safety relay is switched on, the device performs a self test. During this test, the operating mode in which the safety relay is to function is determined on the basis of the wiring. The basic wiring configurations of the individual operating modes are given below.

4.1 Operating mode 1 AOPD

Safety monitoring device with one or more protective sensors connected in series used for safeguarding danger zones or points of operation on machines and systems.

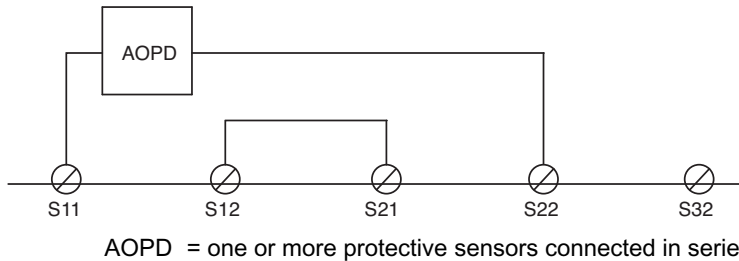



Figure 4.1: Basic wiring for operating mode 1 AOPD (one protective sensor)

 If protective sensors are linked together in the way shown in the connection examples (see figure 7.3 and see figure 7.4), the total delay time (0.5 ms to 8.5 ms) should be noted.

4.2 Operating mode 2 AOPDs

Safety monitoring device with two protective sensors or two series connections consisting of multiple protective sensors used for safeguarding danger zones or points of operation on machines and systems.

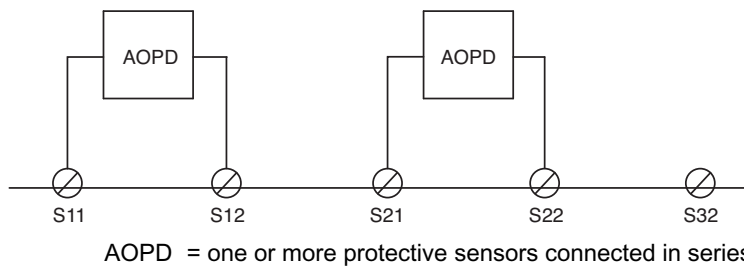



Figure 4.2: Basic wiring for operating mode 2 AOPDs (two protective sensors)

 If protective sensors are linked together in the way shown in the connection examples (see figure 7.7 and see figure 7.8), the total delay time (0.5 ms to 8.5 ms) should be noted.

4.3 Operating mode ES

Safety sequential device for 2-channel E-Stop monitoring with NC contacts.

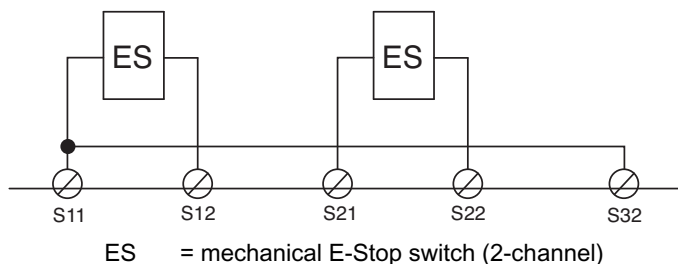



Figure 4.3: Basic wiring of operating mode ES (E-Stop)

 Automatic start is not approved for E-Stop applications.

4.4 Operating mode SG

Safety sequential device for 2-channel safety door monitoring.

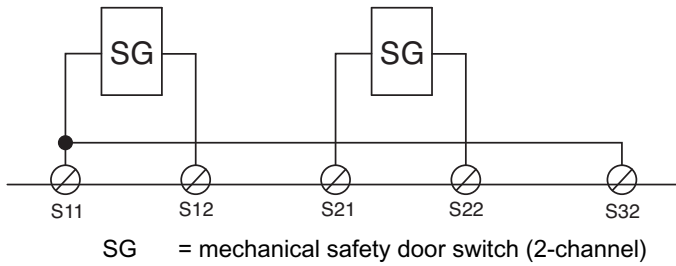



Figure 4.4: Basic wiring for operating mode SG (safety door)

 The safety door monitoring switches must be closed so that the safety switching outputs (OSSD) can close.

4.5 Testing with operating mode 1 AOPD and 2 AOPDs

The protective sensors (AOPDs) are monitored for

- short-circuit with operating voltage (Vcc or GND)
- electrical cross connection
- optical cross connection or short-circuit

For this purpose, control outputs S11 and (after a delay) S21 are clocked.

 The total delay time for a linked series of photoelectric sensors must be in the range from 0.5 ms to 6.5 ms.

4.6 Testing with operating mode ES and SG

The E-Stop and safety door switch is monitored for

- short-circuit with operating voltage (Vcc or GND)
- electrical cross connection

For this purpose, control outputs S11 and (after a delay) S21 are clocked as shown in the diagram below:

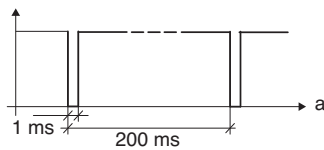

a Test signal of MSI-TRM at S11 and S21

Figure 4.5: Diagram showing clocking of control outputs S11 and S21

4.7 Start/restart interlock and contactor monitoring (EDM)

The start/restart interlock prevents automatic start-up of the system (e.g. if the protective field is again clear or if an interruption in the voltage supply is restored). The operating personnel must make certain that no people are present in the danger zone before the system is manually re-enabled.

The restart interlock is configured via the wiring.

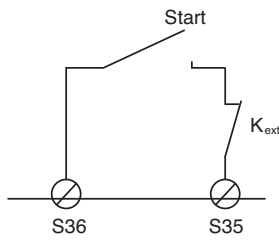

Figure 4.6: Start/restart interlock and contactor monitoring (EDM)

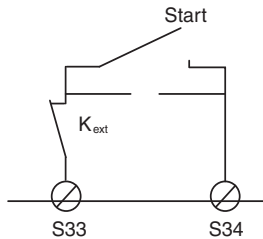

Figure 4.7: Automatic start with EDM

A feedback contact of an external contact extension (K_{ext}) can be connected in series with the start button. Changing between the two start configurations is not allowed during operation. If a change is detected, the device enters the error state and indicates this via the LEDs (see chapter 3.3 "Error display"). The specific wiring of the external relays is shown in the application examples (see figure 7.1 – see figure 7.11). With a monitored start, the device reacts to the falling edge of the start button; with a non-monitored start, it reacts to the rising edge or the static signal.

NOTICE
 Operation of the device in the E-Stop application with automatic start (without restart interlock) is not allowed.

NOTICE
 With monitored start, K_{ext} must be connected between the start button and S35.

4.8 Error state FAIL SAFE

If the device is in an error state (FAIL SAFE), this is indicated by the LEDs (see chapter 3.3 "Error display"). In the error state, the OSSD safety switching outputs (relay outputs) and control outputs S11 and S21 are switched off. The device no longer reacts to input actuation, e.g. pressing of the start button.

The error state can be reset by means of a software reset (see chapter 4.8.1 "Software reset") or by briefly switching off the voltage supply at A1, e.g. using a reset button connected in series to the supply voltage at A1.

4.8.1 Software reset

If the safety relay indicates a fault, it can be reset as follows:

- With monitored start: press the start button for at least 4 s.
- Between S35 and S36: press a button connected for the reset, for at least 4 s.

5 Applications

5.1 Access guarding

Safety relays are used together with single- or multiple light beam safety devices, e.g. as access guarding for danger zones. Because protective sensors only detect persons upon entry into the danger zone, and not whether a person is present in the danger zone, the safety relay only triggers the switch command upon entry of a person into a danger zone. Access guarding may therefore only be operated with activated start/restart interlock or additional safety measures must be taken.

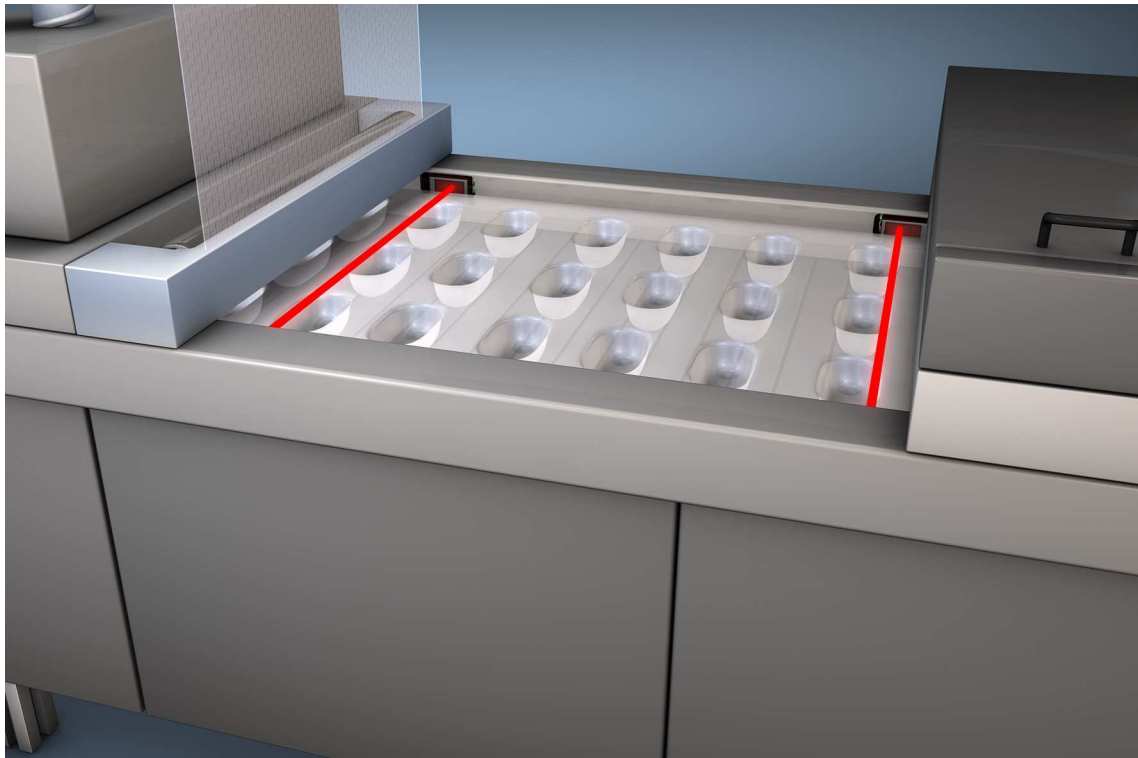

Figure 5.1: Intervention control on packaging machinery



Figure 5.2: Access guarding / intervention control on sawing machines

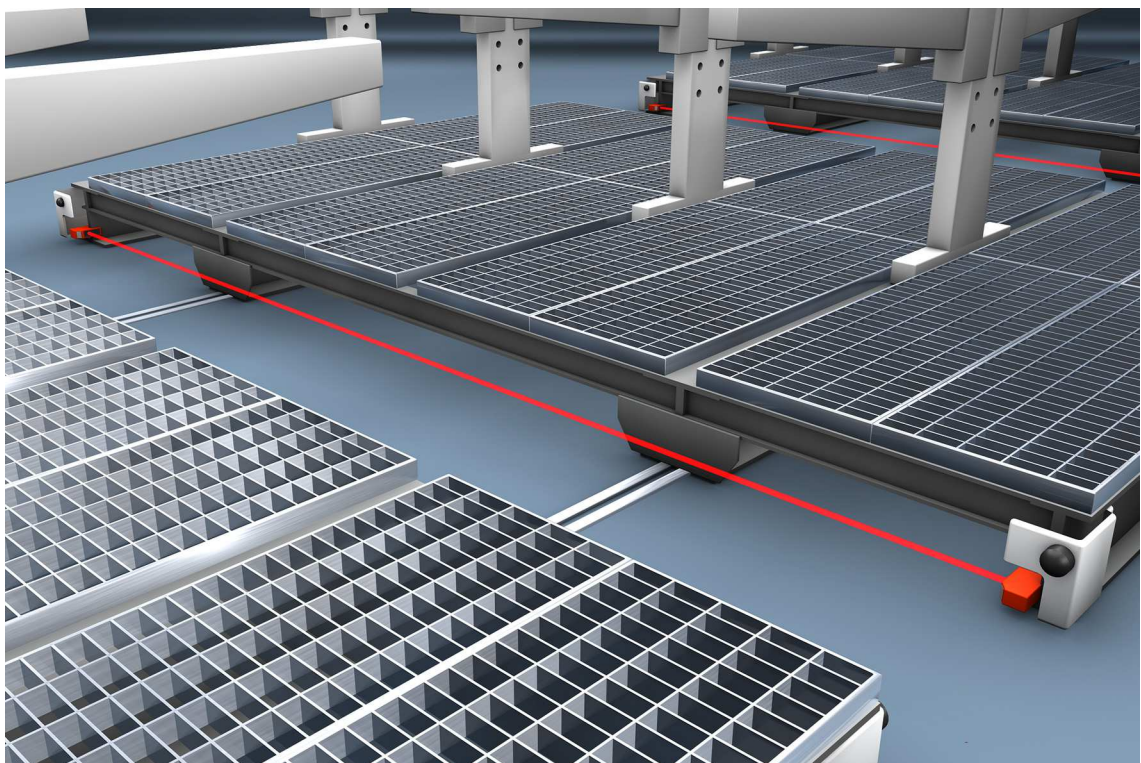



Figure 5.3: Foot space protection on side-tracking shelves

6 Mounting

 **WARNING**

Improper mounting may result in serious injury!
 The protective function of the safety relay is only ensured if appropriately and professionally mounted for the respective, intended area of application.

- ↳ Only allow competent persons to install the safety relay.
- ↳ Observe the relevant standards, regulations and these instructions.

The safety relay is intended for mounting on a DIN rail in the switch cabinet.

Prerequisites for mounting:

- Switch cabinet with appropriate degree of protection (at least IP54).
- Sufficient space on the DIN rail.
- Arrangement of the protective device acc. to EN 999 and IEC/pr EN 61496-2 see chapter 6.1 "Arrangement of the protective device".

↳ Snap the safety relay onto the DIN rail.

The safety relay can be connected to the protective sensor.

6.1 Arrangement of the protective device

Optical protective devices can only perform their protective function if they are mounted with adequate safety distance. When mounting, all delay times must be taken into account, e.g. the response times of the protective sensor and control elements as well as the stopping time of the machine.

The following standards specify calculation formulas:

- EN 999, "Positioning of protective equipment with respect to approach speeds of parts of the human body": mounting situation and safety distances.
- IEC/pr EN 61496-2, "Active Optoelectronic Protective Devices": distance of the reflecting surfaces/ deflecting mirrors.

Table 6.1: Beam heights and distances

Number of beams / beam distance [mm]	Beam heights acc. to EN 999 [mm]
2 / 500	400, 900
3 / 400	300, 700, 1100
4 / 300	300, 600, 900, 1200

6.1.1 Calculating the safety distance

General formula for calculating the safety distance S of an optoelectronic protective device acc. to ISO 13855 or EN 999:

$$S = K \cdot T + C$$

- S [mm] = Safety distance
- K [mm/s] = 1600 mm/s (approach speed for access guarding)
- T [s] = Total time of the delay
- C [mm] = 850 mm (default value for arm length)

↳ Calculate the safety distance S for access guarding using the formula acc. to ISO 13855 or EN 999:

$$S = 1600 \text{ mm} \cdot (t_a + t_i + t_m) + 850 \text{ mm}$$

- S [mm] = Safety distance
- t_a [s] = Response time of the protective device
- t_i [s] = Response time of safety relay
- t_m [s] = Stopping time of the machine



If longer stopping times are determined during regular inspections, an appropriate additional time must be added to t_m .

6.1.2 Multi-axis arrangement

With multi-axis installation, the light beams must run parallel to the reference plane (e.g. floor) and must be aligned mutually parallel.

When mounting multiple protective sensors, no transmitter may be directed any receiver within the series connection other than that which is intended. Note that the operating ranges of photoelectric sensors may be larger than the specified maximum ranges. Correct mounting of the protective sensors must be checked by means of tests and secured against misalignment.

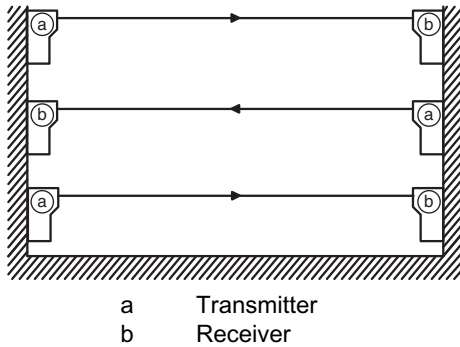

Figure 6.1: Multi-axis arrangement

6.1.3 Minimum distance to reflective surfaces



WARNING

Failure to maintain minimum distances to reflective surfaces may result in serious injury!

Reflective surfaces can indirectly deflect the transmitter beams to the receiver. In this case, interruption of the protective field is not detected.

Make certain that all reflective surfaces are the necessary minimum distance away from the protective field.

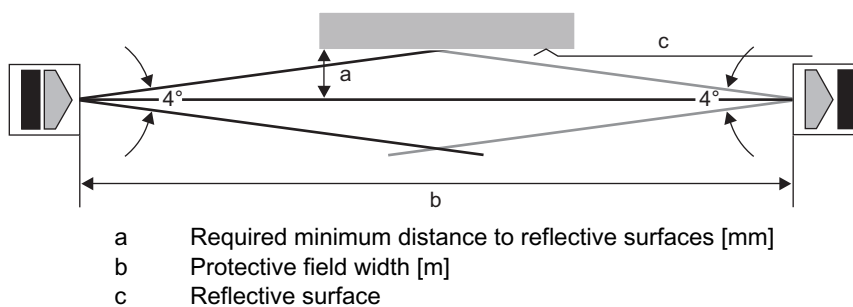

Figure 6.2: Minimum distance to reflective surfaces depending on protective field width

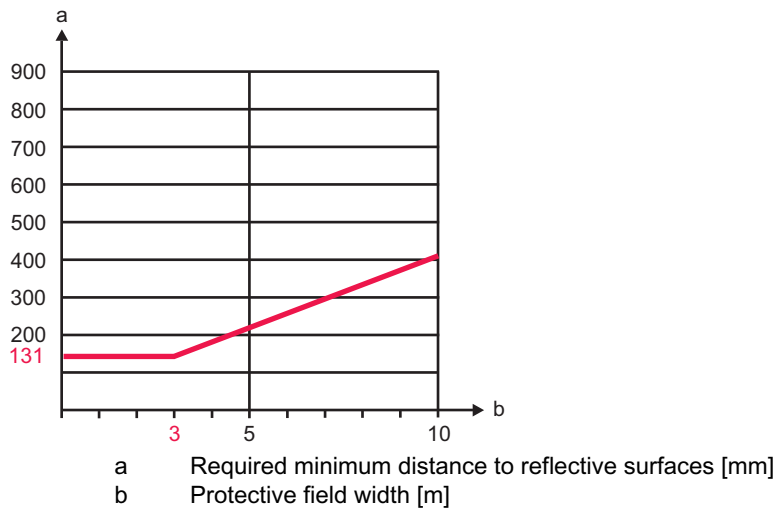

Figure 6.3: Minimum distance to reflective surfaces as a function of the protective field width up to 10 m

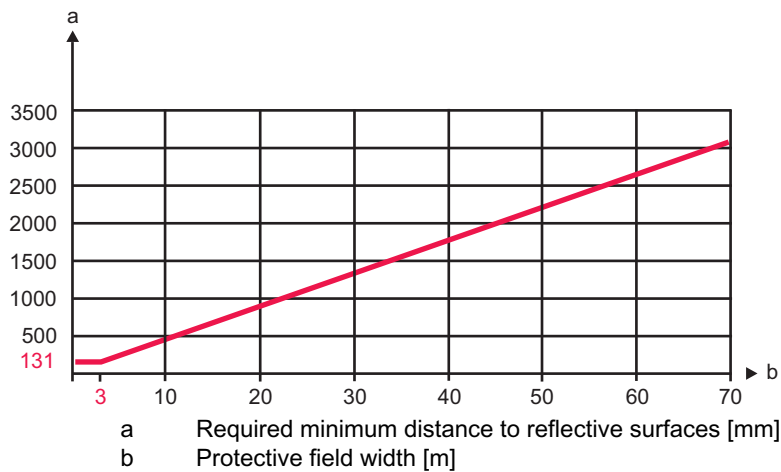

Figure 6.4: Minimum distance to reflective surfaces as a function of the protective field width up to 70 m

↪ Calculate the minimum distance to reflective surfaces depending on the installation situation and according to the following formula:

Table 6.2: Calculating the minimum distance

Distance (b) transmitter-receiver	Calculation of the minimum distance (a) to reflective surfaces
$b \leq 3 \text{ m}$	$a \text{ [mm]} = 131$
$b > 3 \text{ m}$	$a \text{ [mm]} = \tan(2.5^\circ) \times 1000 \times b \text{ [m]} = 43.66 \times b \text{ [m]}$

Deflecting mirrors

When using deflecting mirrors, the following must be observed:

- Range loss per deflecting mirror of approx. 15 %.
- Deflecting mirrors must not be soiled.
- Environmental conditions (vapors or dust-laden air considerably limit the range).
- Arrange the deflecting mirror so that the optical axis is aligned with the center of the mirror see figure 6.5.

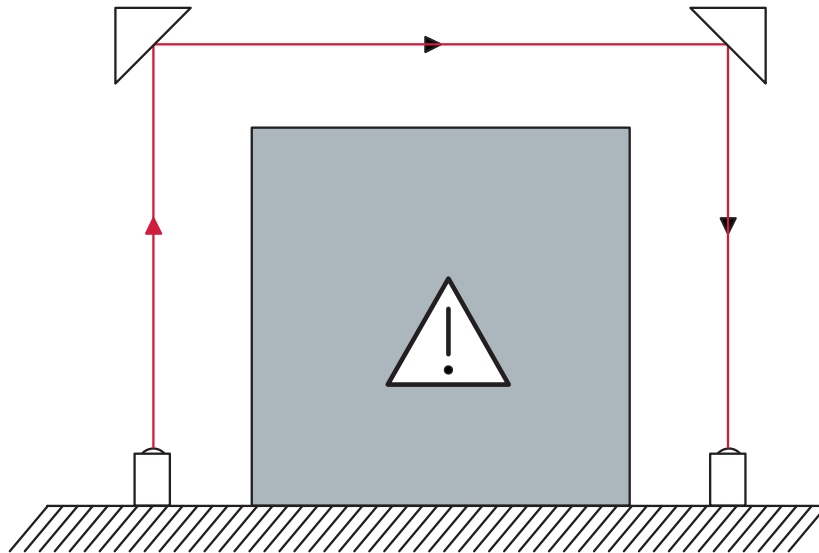

Figure 6.5: Arrangement of the deflecting mirrors

6.1.4 Checklist – mounting the protective sensor

Interval: once prior to establishing the electrical connection

Tester: competent person

Table 6.3: Checklist – mounting the protective sensor

Items on the check list	Yes	No
Do the beam heights satisfy the requirements acc. to EN 999 (see table 6.1)?		
Is the safety distance to the point of operation maintained (see chapter 6.1.1 "Calculating the safety distance")?		
Is the minimum distance to reflective surfaces maintained (see chapter 6.1.3 "Minimum distance to reflective surfaces")?		
Is it ensured that protective sensors cannot mutually influence one another?		
Can the point of operation or the danger zone only be accessed through the protective field?		
Is it ensured that the protective field cannot be circumvented?		
Do the transmitter and receiver connections point in the same direction?		
Is the protective sensor mounted acc. to the corresponding instructions provided by the manufacturer?		
Is the protective sensor accessible for testing and replacing?		
Is it ensured that the start/restart button cannot be activated from within the danger zone?		
Can the entire danger zone be seen from the installation site of the start/restart button?		

7 Electrical connection

 **DANGER**

Risk of death by electric shock!

Depending on external wiring, dangerous voltages may be present at the switching outputs.

↳ During all work at the electrical system or electronics, make certain that each voltage supply has been interrupted and protected against being restarted.

The following must be observed for the current supply of the safety relay:

- Supply voltage 24 V DC +25% / -20%.
- Safe mains separation acc. to IEC 60742 possible.
- A corresponding power supply unit handles interruptions of the supply voltage up to 10 ms in duration acc. to EN 61496-1.

 **WARNING**

Improper electrical connection may result in serious injury!

↳ Only allow competent persons to perform the electrical connection.

↳ Make certain that supply and signal lines are laid separately from power lines.

↳ Use appropriate spark extinction for contactors in the cabinet.

↳ Observe the installation notices and operating instructions of the products that are to be connected via the safety relay (drive motors, brakes, etc.).

The following conditions apply for the electrical connection:

- The safety relay is to be integrated in the control acc. to ISO 13849-1.
- No safety-relevant signal is connected via signal output S31.
- There are always two switching contacts integrated in the system switch-off circuit.
- Relay switching contacts are fused/protected externally according to their specifications (see table 14.3).

NOTICE

Laying cables!

↳ Lay all connection cables and signal lines within the electrical installation space or permanently in cable ducts.

↳ Lay the cables and lines so that they are protected against external damages.

↳ For further information: see EN ISO 13849-2, Table D.4.

7.1 Terminal assignments

 **WARNING**

Selecting the wrong functions may result in serious accidents!

↳ Always connect protective sensors to an external safety relay and activate the restart interlock.

↳ For access guarding, make certain that the restart interlock cannot be unlocked from within the danger zone but that the danger zone can be viewed from the start button.

↳ Select the functions so that the safety relay is used as intended (see chapter 2.1 "Approved purpose and foreseeable improper operation").

Connected to the safety relay are 16 numbered terminals to which the cables for the various functions are connected.

Table 7.1: Terminal assignments

Terminal	Function "1 AOPD": one or more protective sensors connected in series	Function "2 AOPDs": two rows each with at least one protective sensor	ES/E-Stop function or SG/ safety door function
S11	Control output / connection of transmitter	Control output / connection of transmitter 1	Control output / connection of E-Stop or safety door channel 1
S12	Function identifier: bridge S12 to S21	Safety input / receiver 1	Safety input / connection of E-Stop or safety door channel 1
S21		Control output / connection of transmitter 2	Control output / connection of E-Stop or safety door channel 2
S22	Safety input / receiver	Safety input / receiver 2	Safety input / connection of E-Stop or safety door channel 2
S31	Semiconductor output ERROR	Semiconductor output ERROR	Semiconductor output ERROR
S32	Function identifier: not connected	Function identifier: not connected	Function identifier: bridge to S11
S33	Start application: automatic and non-monitored start (restart interlock)	Start application: automatic and non-monitored start (restart interlock)	Start application: automatic and non-monitored start (restart interlock)
S34			
A1	+24 V	+24 V	+24 V
S35	Start application: monitored start (restart interlock)	Start application: monitored start (restart interlock)	Start application: monitored start (restart interlock)
S36			
A2	GND	GND	GND
13	OSSD-1	OSSD-1	OSSD-1
14			
23	OSSD-2	OSSD-2	OSSD-2
24			

Configuration of start application

Further information: see chapter 4.7.

Table 7.2: Configuration of start application

Function	Terminals
Operation with start/restart interlock (monitored start)	Start button between terminal S35 and S36
Non-monitored start / automatic start	Start button / bridge between terminal S33 and S34

↪ Trigger a reset (software reset via the start button if the device is in the error state, or by briefly switching off the voltage supply to A1).

The new settings are accepted.

Configuration EDM

Further information: see chapter 4.7.

Table 7.3: Configuration EDM

Function	Terminals
EDM selected	Monitored start: External device monitoring circuit (EDM) is connected to the start button and terminal S35 in series relative to the starter button Non-monitored start: External device monitoring circuit (EDM) is connected to the start button and terminal S34 in series relative to the starter button Automatic start: External device monitoring circuit (EDM) is connected to terminals S33 and S34 in place of the bridge for automatic start

↪ Trigger a reset (software reset via the start button if the device is in the error state, or by briefly switching off the voltage supply at A1 / using reset button connected in series to the supply voltage at A1).

The new settings are accepted.

Connection examples

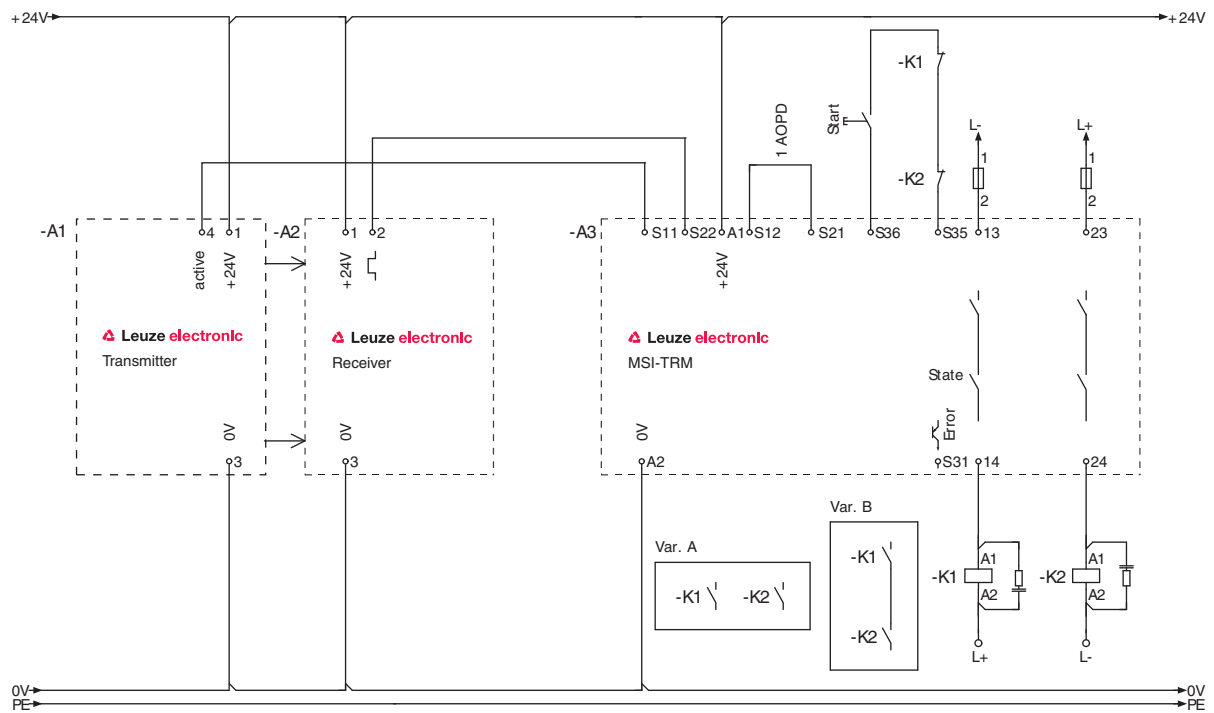

Figure 7.1: Safety monitoring device with one protective sensor with monitored start (restart interlock)

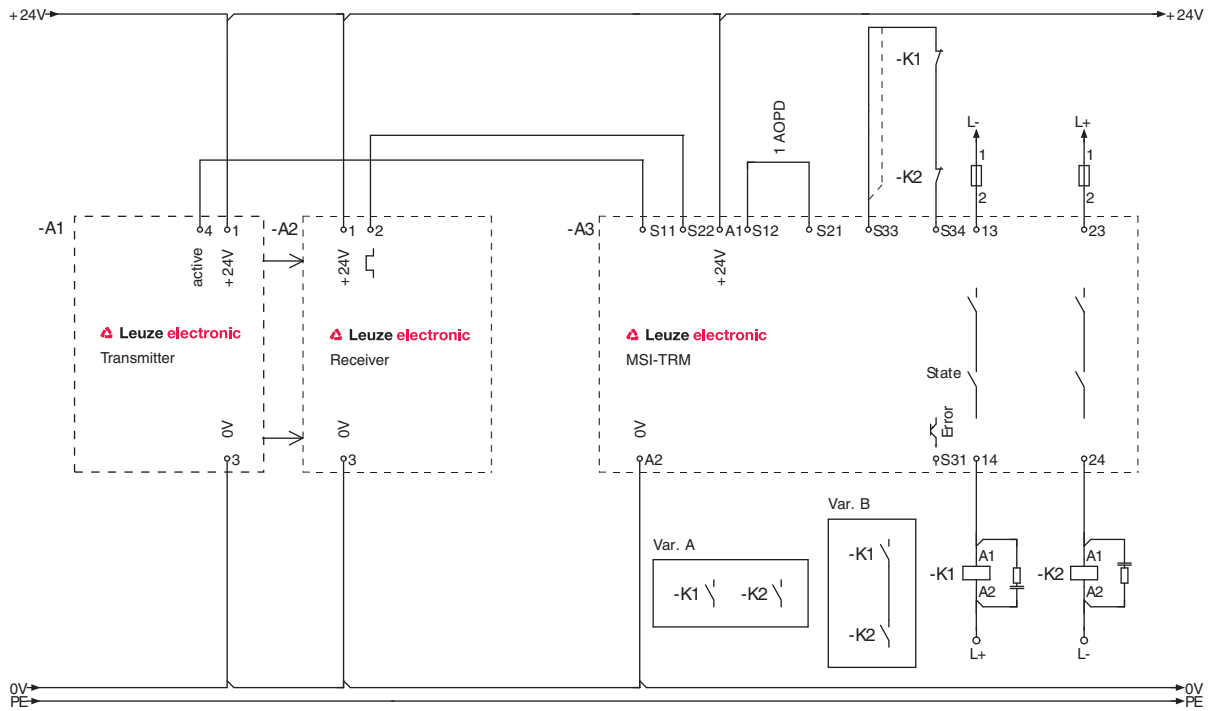

Figure 7.2: Safety monitoring device with one protective sensor with automatic start and non-monitored start

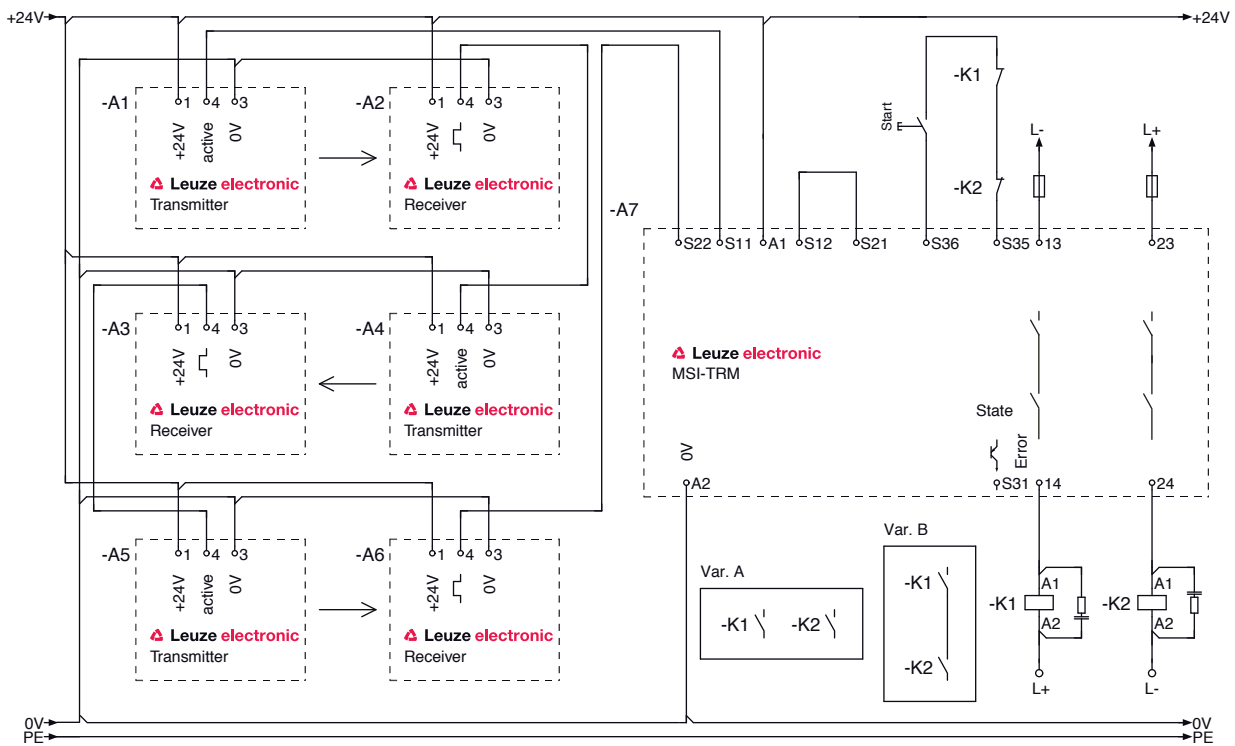

Figure 7.3: Safety monitoring device with series connection consisting of multiple protective sensors with monitored start (restart interlock)



Note the total delay time of the photoelectric sensors (0.5 ms to 8.5 ms)

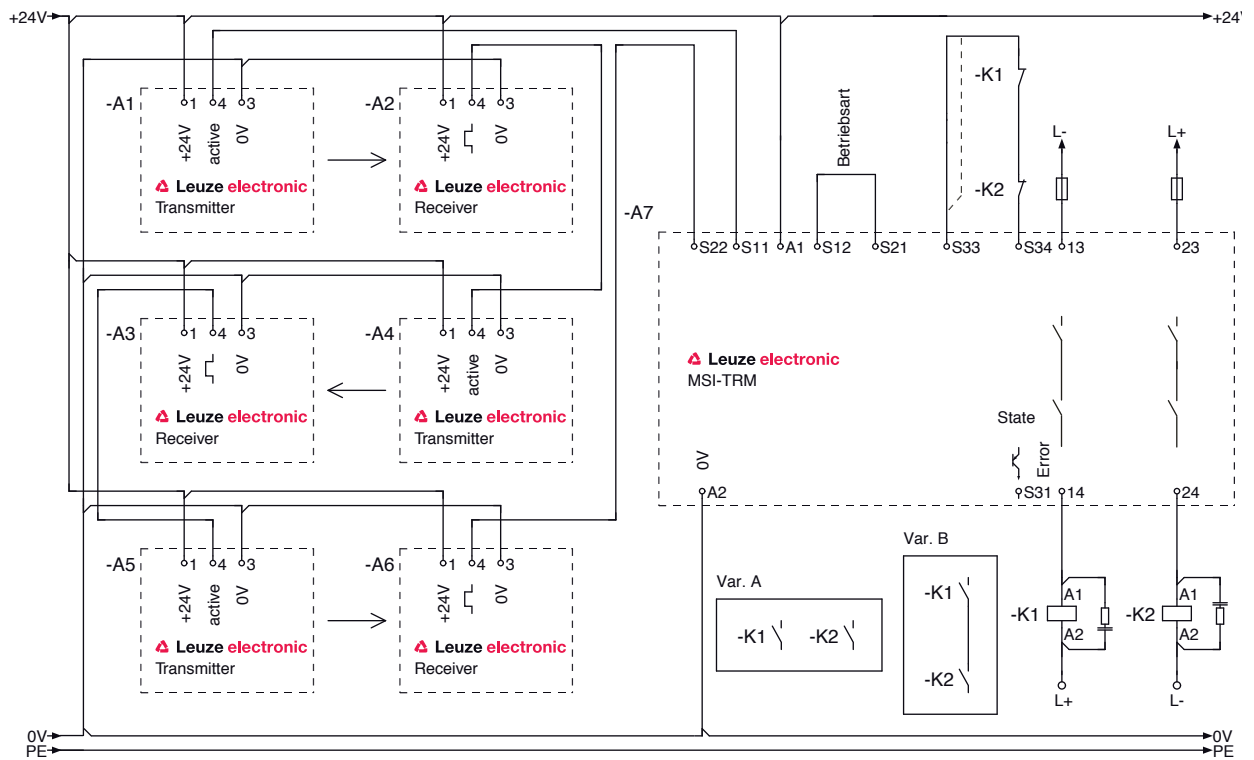

Figure 7.4: Safety monitoring device with series connection consisting of multiple protective sensors with automatic start



Note the total delay time of the photoelectric sensors (0.5 ms to 8.5 ms)

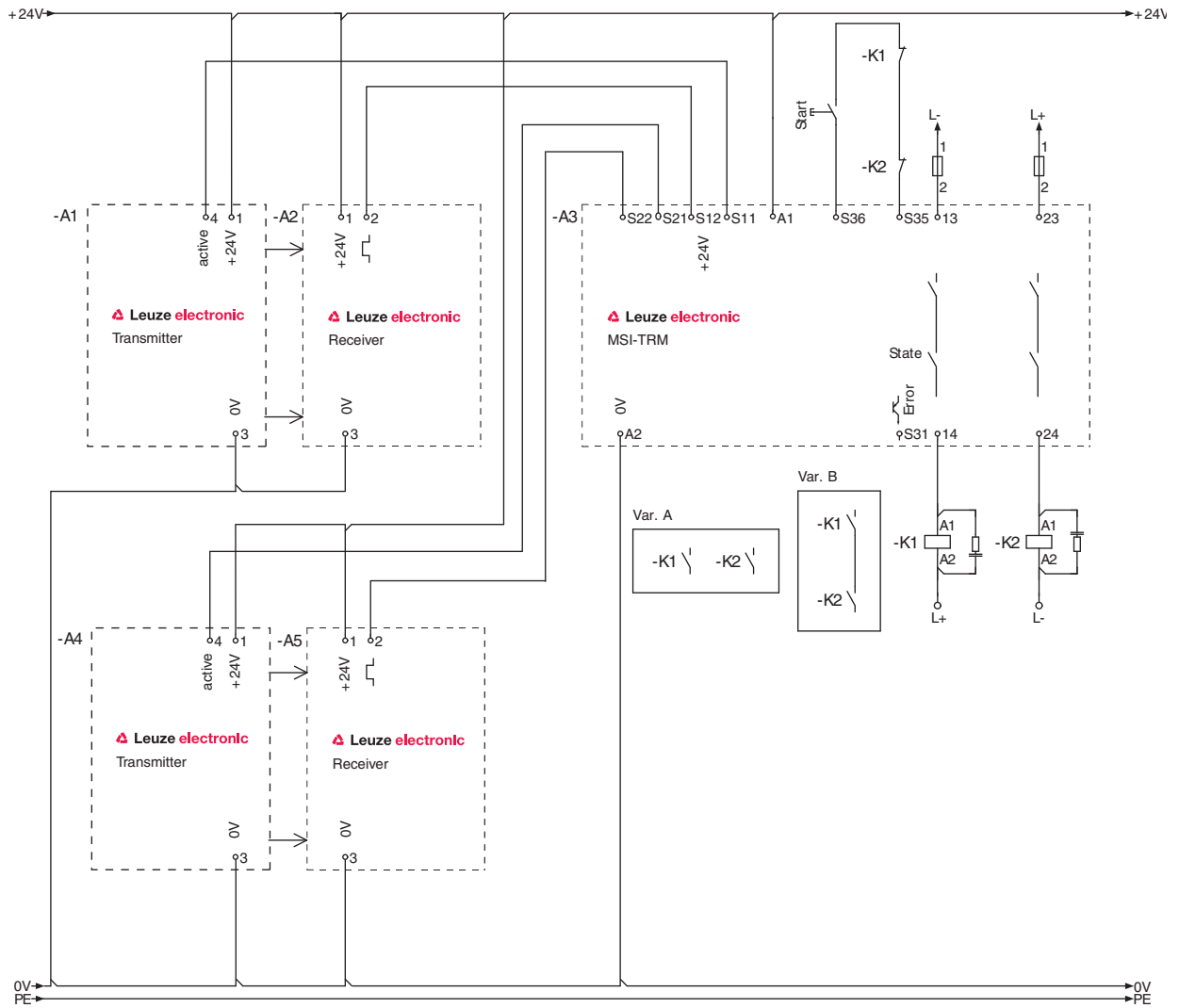

Figure 7.5: Safety monitoring device with two protective sensors with monitored start (restart interlock)

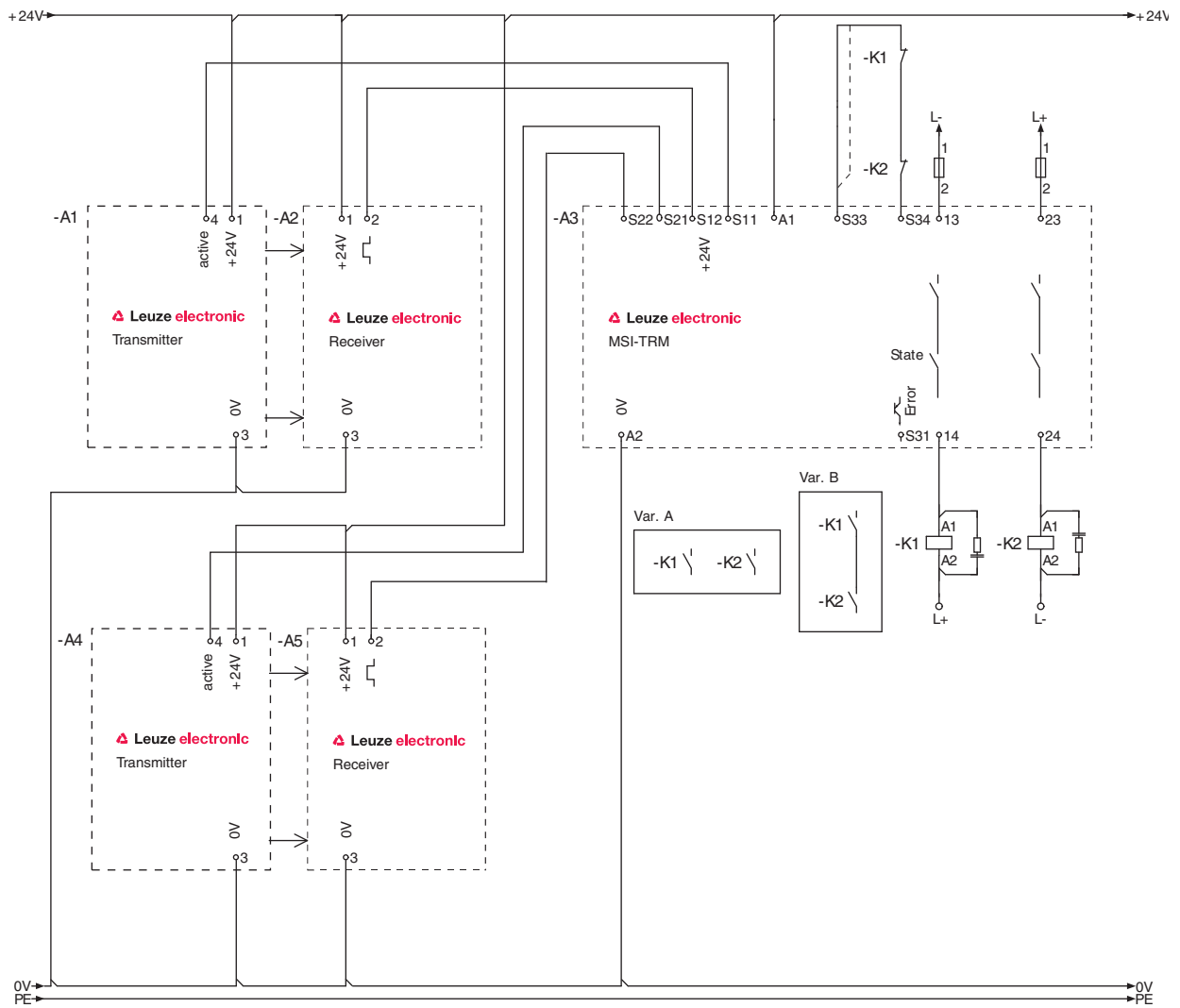

Figure 7.6: Safety monitoring device with two protective sensors with automatic start

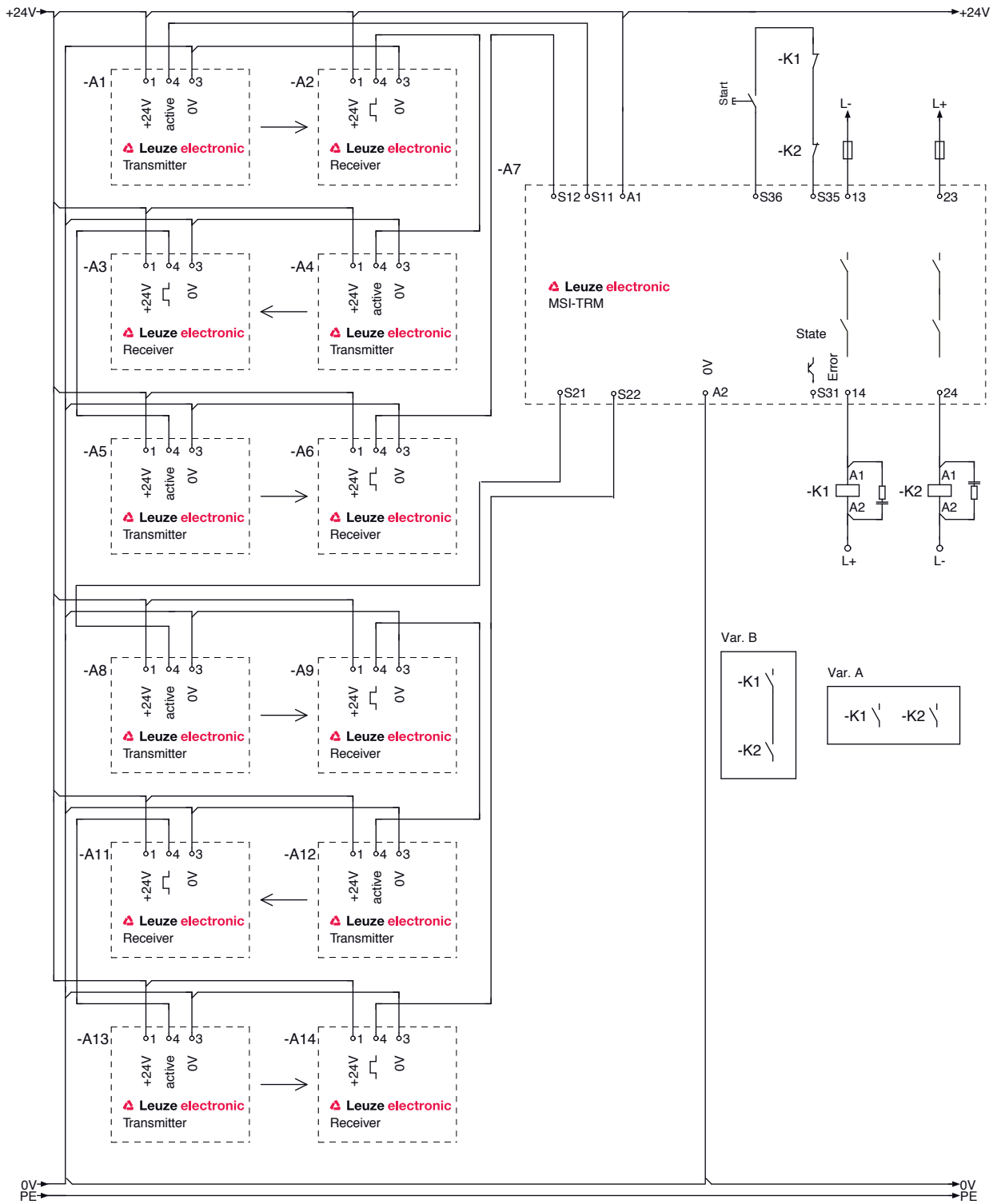

Figure 7.7: Safety monitoring device with two series connections consisting of multiple protective sensors with monitored start (restart interlock)



Note the total delay time of the photoelectric sensors (0.5 ms to 8.5 ms)

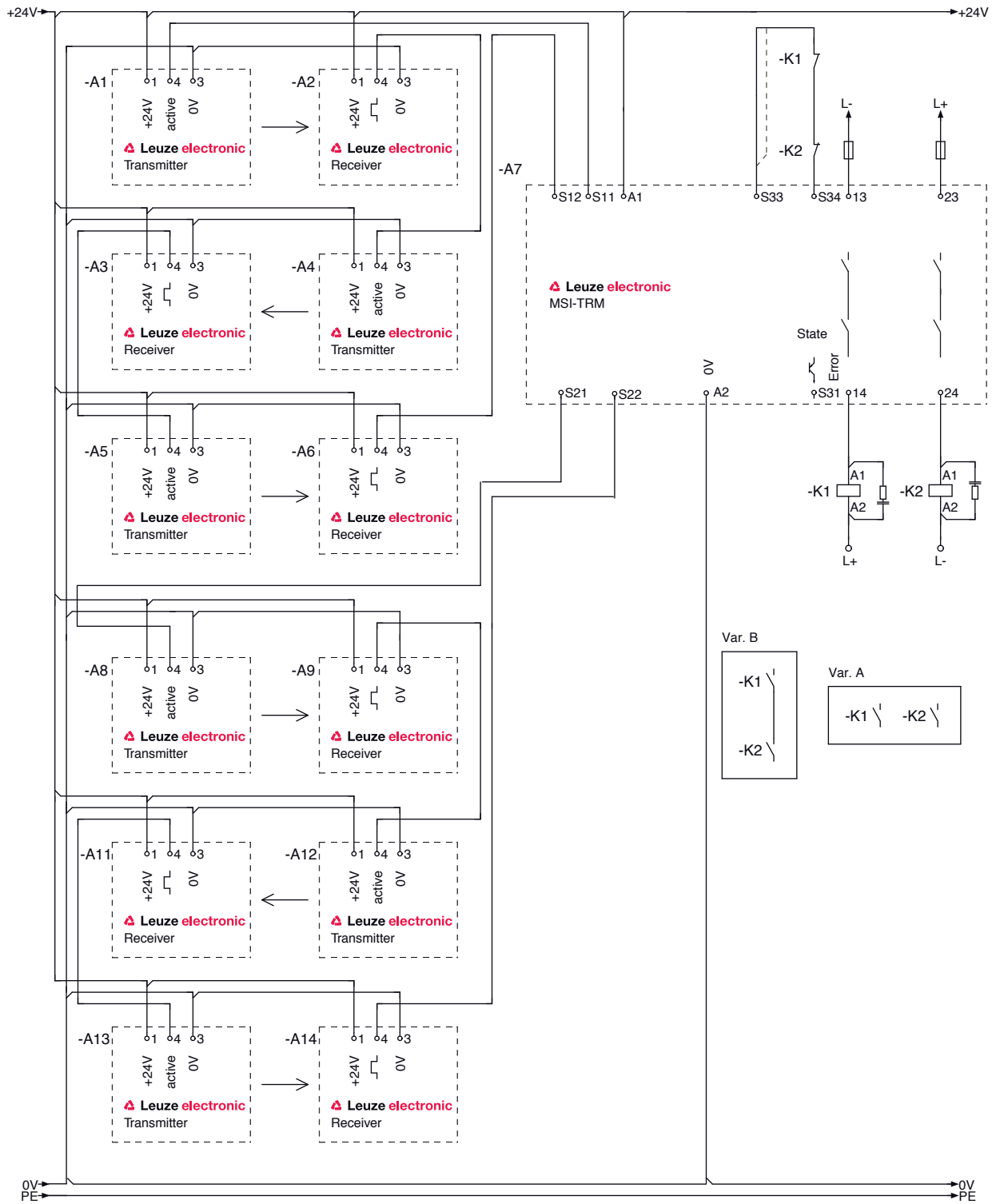

Figure 7.8: Safety monitoring device with two series connections consisting of multiple protective sensors with automatic start



Note the total delay time of the photoelectric sensors (0.5 ms to 8.5 ms)

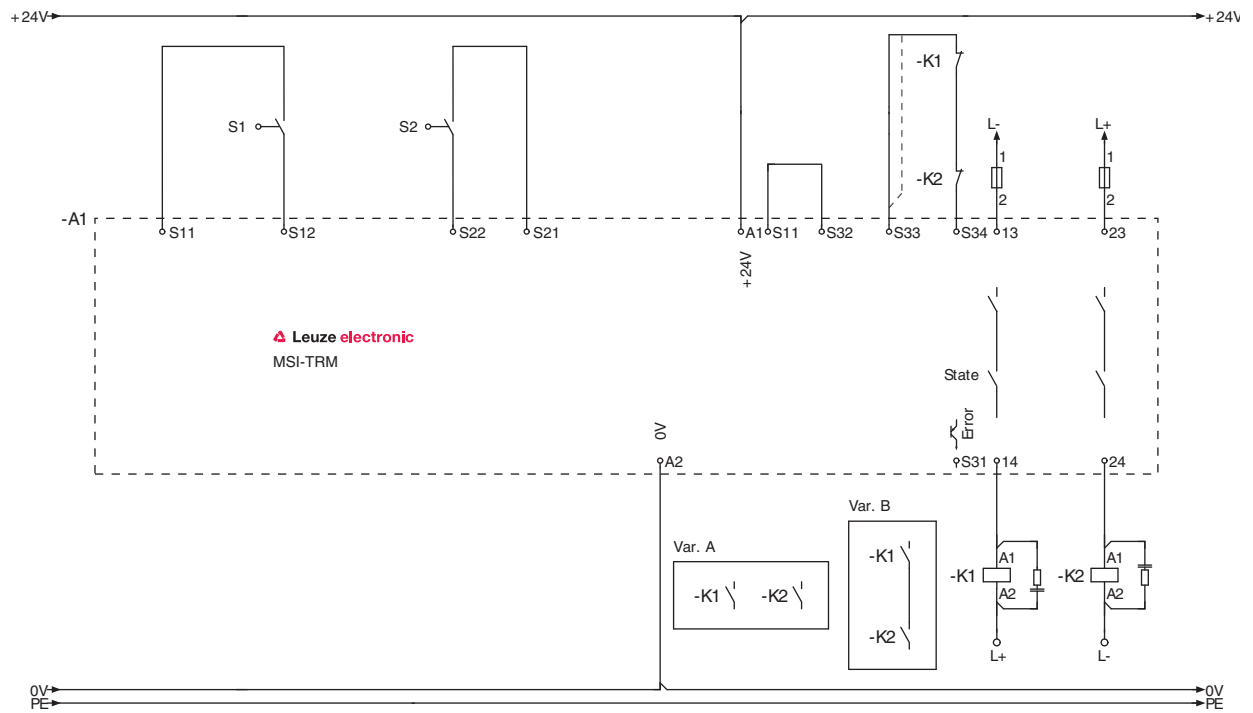

Figure 7.11: Safety sequential device for 2-channel safety door monitoring with automatic start and non-monitored start (restart interlock)

8 Starting up the device

WARNING

Improper use of the safety relay may result in serious injury!

- ↪ Make sure that the entire device and the integration of the optoelectronic protective device and E-Stop or safety door switch has been checked by competent and instructed persons.
- ↪ Make certain that a dangerous process can only be started while the safety sensor is switched on.

Prerequisites:

- The protective sensor, the E-Stop or safety door switches and the safety relay were mounted and connected in accordance with the respective instructions.
 - Operating personnel were instructed on proper use.
 - The dangerous process has been switched off, the outputs of the protective sensor in the case of photoelectric sensor applications have been disconnected and measures have been taken to prevent the system from being switched on again.
- ↪ During start-up, test the function of the safety relay (see chapter 9 "Testing").

8.1 Switching on

Requirements for the supply voltage (power supply unit):

- Safe mains separation is ensured (acc. to IEC 60742).
- Changes and interruptions of the supply voltage are handled (acc. to EN 61496-1).
- The start/restart interlock function is connected and activated.

↪ Switch on the current supply.

↪ Check whether the "PWR" LED on the safety relay lights up.

The safety relay is ready for use.

8.2 Start/restart

The start/restart button can be used to unlock the start/restart interlock. In this way, the responsible person can restore normal operation of the system following process interruptions (triggering of the protective function, failure of the voltage supply) see chapter 8.2.1 "Unlocking start/restart interlock".

With automatic start, it remains unlocked for as long as connection terminals S33 and S34 are bridged.

8.2.1 Unlocking start/restart interlock

WARNING

Premature unlocking of the start/restart interlock may result in serious injury!

If the start/restart interlock is unlocked, the system can start up automatically.

- ↪ Before unlocking the start/restart interlock, make certain that no people are in the danger zone.

The red and yellow LEDs illuminate as long as the restart is disabled.

↪ Make certain that the active protective field is clear.

↪ If the active protective field is not clear, select a different procedure .

↪ Make certain that there are no people in the danger zone.

↪ Press the start/restart button and release it again (after 0.06 ... 4 s).

The safety relay switches back to the "ON" state.

9 Testing

 WARNING
<p>A running machine may result in serious injury!</p> <p>↪ Make certain that, during all conversions, maintenance work and inspections, the system is securely shut down and protected against being restarted.</p>

The safety relays must be exchanged after a maximum of 20 years.

- ↪ Always exchange the entire safety relay.
- ↪ For the tests, observe nationally applicable regulations.
- ↪ Document all tests in a comprehensible manner.

9.1 Before the initial start-up and following modifications

Acc. to IEC TS62046 and national regulations, tests are to be performed by competent persons in the following situations:

- Prior to the initial start-up
- Following modification to the machine
- After longer machine downtime
- After retrofitting or reconfiguring the safety device (safety relay and/or protective sensor)

 WARNING
<p>Unpredictable machine behavior during initial start-up may result in serious injury!</p> <p>↪ Make certain that there are no people in the danger zone.</p>

- ↪ Test the effectiveness of the shutdown function in all operating modes of the machine acc. to the corresponding checklist see chapter 9.1.1 "Checklist – initial start-up".
- ↪ Document all tests in a comprehensible manner and include the configuration of the safety relay along with the data for the safety and minimum distances in the documentation.
- ↪ Before they begin work, train the operating personnel on their respective tasks. The training is the responsibility of the operating company.
- ↪ Check whether the safety relay was correctly selected acc. to the locally applicable regulations and directives.
- ↪ Check whether the safety relay is operated acc. to the specified environmental conditions (see chapter 14 "Technical data").
- ↪ Make certain that the safety relay is protected against overcurrent.
- ↪ Perform a visual inspection for damage and test the electrical function see chapter 9.2 "To be performed periodically by a competent person".

Minimum requirements for the power supply unit:

- Safe mains separation.
- Power-failure bridging for at least 10 ms.

The optoelectronic safety device, the E-Stop or safety door switch and the safety relay are not allowed to be integrated in the control circuit of the system until a check has been performed to ensure that they are functioning correctly.



As a safety inspection, Leuze electronic offers testing by a competent person prior to the initial start-up (see chapter 13 "Service and support").

9.1.1 Checklist – initial start-up

Interval: once, prior to the initial start-up and following modification

Tester: competent person

Table 9.1: Checklist – initial start-up

Items on the check list	Yes	No
Were all safety directives and standards relevant to this machine type observed?		
Does the declaration of conformity of the machine include a listing of these documents?		
Does the safety relay satisfy the safety-related capability (PL, SIL, category) as required by the risk assessment?		
Circuit diagram: Are the safety-related switching outputs (OSSDs) integrated in the downstream machine control acc. to the required safety category?		
Are the switching elements (e.g. contactors) with positive-guided contacts that are controlled by the safety relay monitored by an external device monitoring circuit (EDM)?		
Does the electrical wiring match the circuit diagrams?		
Have the required protective measures against electrical shock been effectively implemented?		
Has the maximum stopping time of the machine been remeasured and recorded in the machine documents?		
Is the required safety distance (protective field to the next point of operation) maintained? (With optoelectronic applications only)		
Are all points of operation of the machine accessible only through the protective field? Are all additional protective devices (e.g. safety guards) correctly mounted and protected against tampering?		
Is the command device for triggering the start/restart interlock of the safety relay or the machine mounted in accordance with specifications? (Not with the automatic start application)		
Are safety relay, connecting cable, plug, protection caps and command devices undamaged and free of any signs of manipulation?		
Has the effectiveness of the protective function been ensured for all operating modes of the machine by means of a function test?		
Is the start/restart button for resetting the safety relay mounted outside of the danger zone in accordance with specifications in such a way that it cannot be reached from within the danger zone? Can the entire danger zone be seen from the place at which the start/restart button is installed? (Not with the automatic start application)		
Does the interruption of any given beam cause the dangerous movement to stop? (With optoelectronic applications only)		
When the AOPD is separated from its supply voltage, does the dangerous movement stop, and, after the supply voltage has been restored, is it necessary to actuate the start/restart button to reset the machine? (Only with optoelectronic applications with non-monitored or monitored start)		
Is the safety relay/protective sensor effective during the entire dangerous movement of the machine?		
Are the notices for daily testing of the safety sensor legible to the operating personnel and are they located in a highly visible location?		
Is the muting indicator visibly mounted on the entry/exit path?		

📁 Store this checklist with the machine documents.

9.2 To be performed periodically by a competent person

The reliable interaction of safety sensor, safety relay and machine must be periodically tested in order to detect changes to the machine or impermissible tampering with the safety sensor. Testing intervals are determined by nationally applicable regulations (recommendation acc. to IEC TS62046: 6 months).

- ↪ Have all tests performed by competent persons.
- ↪ Observe the nationally applicable regulations and the time periods specified therein.



As a safety inspection, Leuze electronic offers periodic testing by a competent person (see chapter 13 "Service and support").

9.3 To be performed daily by the operating personnel

The function of the safety relay must be checked daily or at change of shifts, and at each change of machine operating mode as specified in the corresponding checklist see chapter 9.3.1 "Check list – daily or at change of shift" so that damages or unauthorized manipulations can be detected.

WARNING
Unpredictable machine behavior during the test may result in serious injury! ↪ Make certain that there are no people in the danger zone.

WARNING
Faults during the daily inspection may result in serious injury! If you answer one of the items on the check list with "no", the machine must no longer be operated (see table 9.2). ↪ Have the entire machine inspected by a competent person see chapter 9.1 "Before the initial start-up and following modifications".

- ↪ For configurations without automatic start:
 Stop the dangerous state.
- ↪ Check the safety relay, E-Stop or safety door switch, transmitter, receiver of the AOPDs and, if applicable, deflecting mirrors for damage or tampering.
- ↪ Operation as downstream device for ESPE: Interrupt the light beam of the protective sensor using a test rod from a position outside the danger zone and ensure that the machine cannot be started when the light beam is interrupted. Operation as downstream device for E-Stop / safety door: Press the E-Stop switch or open the safety door and make sure that the machine cannot be started with the E-Stop switch pressed or the safety door open.
- ↪ Start the machine.
 For all configurations:
- ↪ Make sure that the dangerous state is stopped as soon as a light beam is interrupted with a test rod, the E-Stop switch is pressed or the safety door is opened.

9.3.1 Check list – daily or at change of shift

Interval: daily or at shift change

Tester: authorized operating personnel or instructed person

Table 9.2: Check list – daily or at change of shift

Items on the check list	Yes	No
Are the safety relay, protective sensor, E-Stop or safety door switch, connecting cables, plugs and command devices undamaged and show no signs of tampering?		
Are all points of operation at the machine accessible only through one or more protective fields of protective sensors?		
Are all additional protective devices mounted correctly (e.g., safety guard)?		
Are all E-Stop switches freely accessible?		
Does the start/restart interlock prevent the automatic start-up of the machine after the protective sensor/safety relay has been switched on or activated?		
↪ Interrupt a light beam of the protective sensor with a test object during operation. Is the dangerous movement shut down immediately?		

10 Maintenance

The safety relay is maintenance-free.

11 Troubleshooting

11.1 What to do in case of error?

After switching on the safety relay, display elements (LEDs, see chapter 3.2 "Display elements" see chapter 3.3 "Error display") assist in checking the proper function and troubleshooting.

In case of error, you can determine the error from the LED displays. With the error message you can determine the cause of the error and initiate measures to rectifying it.

NOTICE
If the safety relay indicates a fault, it may be defective.
↳ Switch off the machine and leave it switched off.
↳ Analyze and eliminate the cause of the fault see chapter 11.2 "Operating displays of the LEDs".
↳ If you are unable to rectify the fault, contact the Leuze branch responsible for you or call the Leuze electronic Hotline.

11.2 Operating displays of the LEDs

LED	State	Cause	Measure
EDM	Flashing	Fault in the EDM wiring	Check the wiring of the connected contactors.
Sensor	Flashing	Fault in the wiring of the protective sensors	Check the wiring of the protective sensors.
Sensor, EDM and start	simultaneous flashing	Internal device error	In the event of an unsuccessful restart, contact customer service.

12 Disposing

↳ For disposal observe the applicable national regulations regarding electronic components.

13 Service and support

24-hour on-call service at:
+49 (0) 702 573-0

Service hotline:
+49 (0) 8141 5350-111
Monday to Thursday, 8.00 a.m. to 5.00 p.m. (UTC+1)
Friday, 8.00 a.m. to 4.00 p.m. (UTC+1)

E-mail:
service.protect@leuze.de

Return address for repairs:
Service center
Leuze electronic GmbH + Co. KG
In der Braike 1
D-73277 Owen / Germany

14 Technical data

14.1 General specifications

Table 14.1: Safety-relevant technical data

Type in accordance with IEC/EN 61496	Type 4
SILCL in accordance with IEC/EN 62061	SILCL 3
Performance Level (PL) acc. to EN ISO 13849-1:2008	Up to PL e
Category acc. to EN ISO 13849-1	Category 4
Probability of a dangerous failure per hour (PFH _b)	2.15x10 ⁻⁹ 1/h
Mean time to dangerous failure (MTTF _d)	> 100 years
Service life (T _M)	20 years

Table 14.2: Electrical data, degree of protection, environment, cable data

Operating voltage U _B	+24 V DC ±20 % (SELV)
Voltage range	80 - 125 %
Residual ripple	< 15 %
Power consumption at UB without load	< 3 W
Current consumption	Approx. 200 mA
Response time	130 ms
Sensor response time upon test request	0.5 ... 8.5 ms
Safety class	III
Degree of protection of housing and terminals	IP20 (only suitable for use in operating rooms/cabinets with minimum protection degree of IP54)
Temperature range, operation	-25 ... +55 °C
Temperature range, storage	-25 ... +75 °C
Relative humidity (non-condensing)	< 75%
Impact resistance	10 g
Dimensions	see chapter 14.2 "Dimensions"
Weight	Max. 155 g
Conductor connection (wire)	0.2 mm ² ... 1.5 mm ²
Tightening torque for connection terminals	0.5 ... 0.6 Nm

Table 14.3: Inputs/outputs

Max. load of control outputs S11, S21	I _{Max} ≤ 50 mA / 24 V DC, short-circuit proof
Transmitter activation	PNP (high active)
Receiver input	Input current approx. 5 mA
Start inputs S34, S35 (depending on application)	Typ. input current 8 mA / 24 V DC

Safety inputs S12, S22	Typ. input current 8 mA / 24 V DC
Reset input	Input current approx. 5 mA
Contact monitoring (EDM)	Typ. input current 8 mA / 24 V DC
Signal output S31	PNP transistor output, ≤ 50 mA / 24 V DC, short-circuit proof
Indication output Error	PNP transistor output, 100 mA, short-circuit and polarity reversal protection
Safety output	2 potential-free NO contacts 5 ... 250 V AC/DC, 5 mA ... 3 A
Fuse protection	External with max. 3 A F or 3 A T
Overvoltage category	3 for rated voltage 300 V AC in accordance with EN 50178

14.2 Dimensions

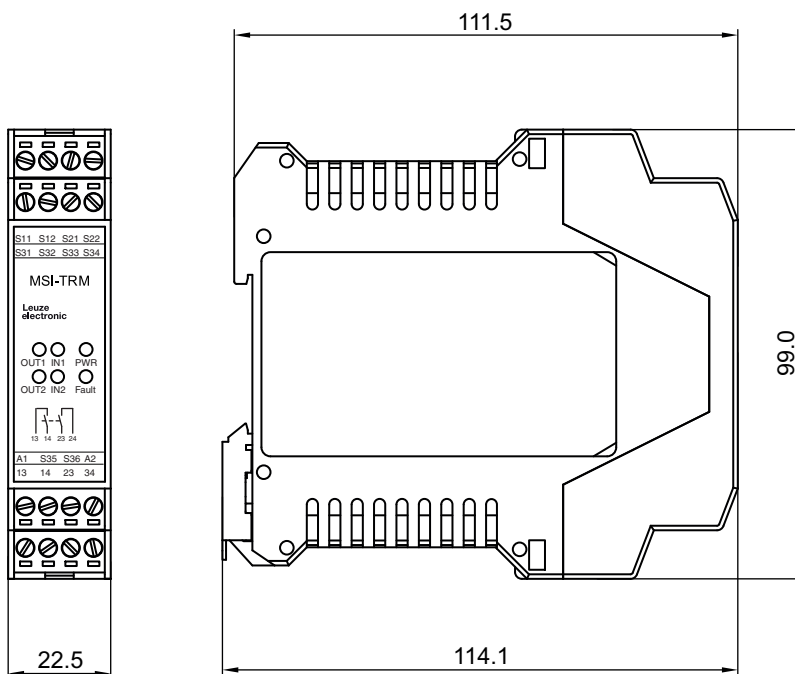

Figure 14.1: Dimensions MSI-TRMB-01

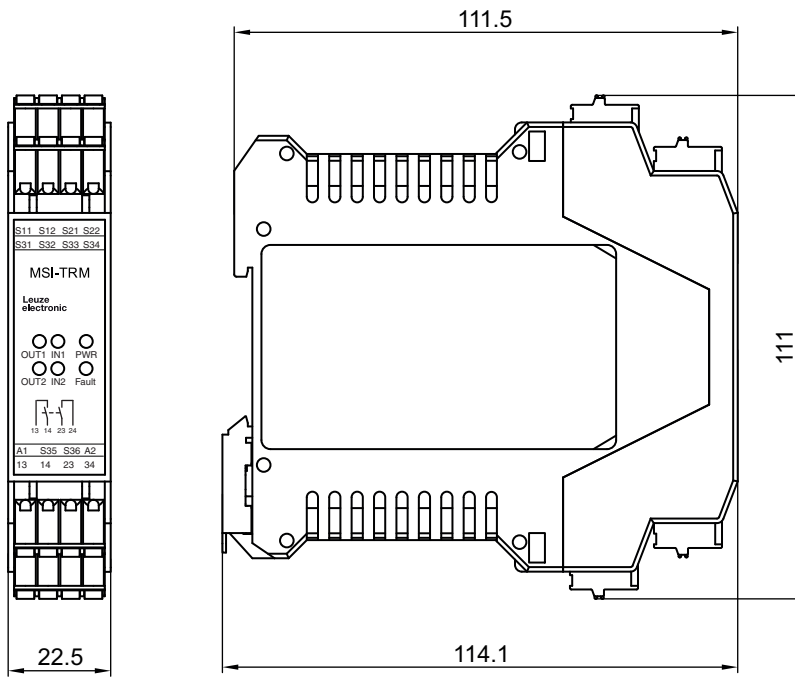

Figure 14.2: Dimensions MSI-TRMB-02

15 Ordering information and accessories

Table 15.1: Safety relay MSI-TRM

Part no.	Article	Description
547931	MSI-TRMB-01	Safety relay for type 4 protective sensors, screw terminals
547932	MSI-TRMB-02	Safety relay for type 4 protective sensors, spring-cage terminals

16 Declaration of Conformity



EG-KONFORMITÄTS- ERKLÄRUNG (ORIGINAL)	EC DECLARATION OF CONFORMITY (ORIGINAL)	DECLARATION CE DE CONFORMITE (ORIGINAL)
Der Hersteller	The Manufacturer	Le constructeur
	Leuze electronic GmbH + Co. KG In der Braike 1, PO Box 1111 73277 Owen, Germany	
erklärt, dass die nachfolgend aufgeführten Produkte den einschlägigen Anforderungen der genannten EG-Richtlinien und Normen entsprechen.	declares that the following listed products fulfil the relevant provisions of the mentioned EC Directives and standards.	déclare que les produits identifiés suivants sont conformes aux directives CE et normes mentionnées.
Produktbeschreibung:	Description of product:	Description de produit:
Sicherheits-Schaltgerät, Sicherheitsbauteil nach 2006/42/EG Anhang IV MSI-TRM Seriennummer siehe Typschild	Safety relay, safety component in acc. with 2006/42/EC annex IV MSI-TRM Serial no. see name plates	Relais de sécurité, élément de sécurité selon 2006/42/CE annexe IV MSI-TRM N° série voir plaques signalétiques
Angewandte EG-Richtlinie(n):	Applied EC Directive(s):	Directive(s) CE appliquées:
2006/42/EG 2004/108/EG	2006/42/EC 2004/108/EC	2006/42/CE 2004/108/CE
Angewandte Normen:	Applied standards:	Normes appliquées:
EN ISO 13849-1:2008 (Kat. 4, Pl e); EN 61496-1 :2012; EN 62061 :2005 (SIL 3);		
Benannte Stelle / Baumusterprüfbescheinigung:	Notified Body / Certificate of Type Examination:	Organisme notifié / Attestation d'examen CE de type:
TÜV Nord CERT GmbH Langemarckstraße 20 45141 Essen		
Bevollmächtigter für die Zusammenstellung der technischen Unterlagen:	Authorized person to compile the technical file:	Personne autorisée à constituer le dossier technique:
André Thieme; Leuze electronic GmbH + Co. KG, business unit safety systems Liebigstr. 4; 82256 Fuerstenfeldbruck; Germany		

Owen, 09.01.2014
Datum / Date / Date

Ulrich Balbach, Geschäftsführer / Director / Directeur

Leuze electronic GmbH + Co. KG, Sitz Owen | Registergericht Stuttgart, HRA 230712
Liebigstraße 4, D-82256 Fuerstenfeldbruck | T +49 8141 5350-0, F +49 8141 5350-190 | info@leuze.de, www.leuze.de
Persönlich haftende Gesellschafterin:
Leuze electronic Geschäftsführungs-GmbH, Sitz Owen | Registergericht Stuttgart, HRB 230550
Geschäftsführer: Ulrich Balbach
USt.IdNr. DE145912521 | Zollnummer 2554232
Es gelten ausschließlich unsere aktuellen Verkaufs- und Lieferbedingungen.

