

ODSL 9

Optical laser distance sensors

en 02-2012/11 50118551



Dimensioned drawing

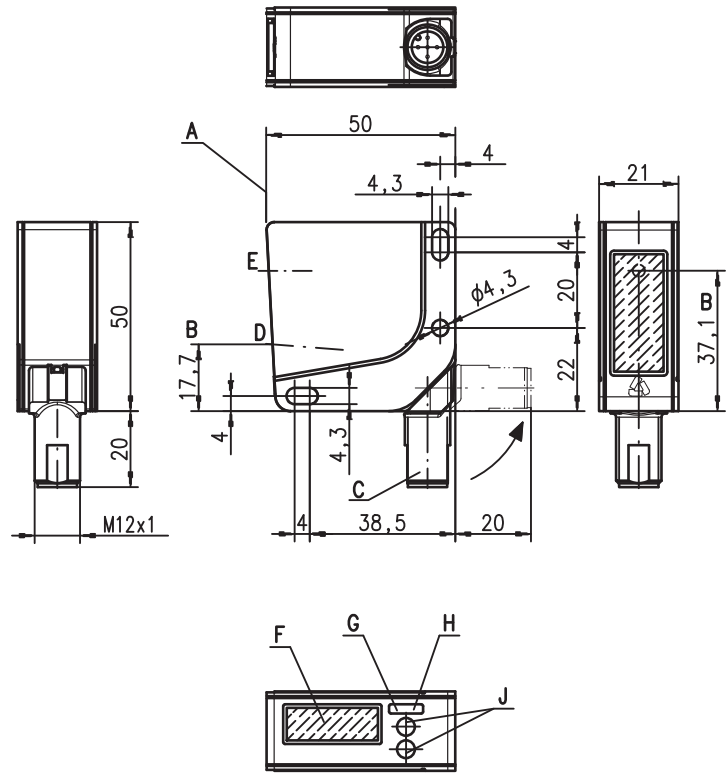

- A Reference edge for the measurement
- B Optical axis
- C Device plug M12
- D Receiver
- E Transmitter
- F LCD display
- G Indicator diode yellow
- H Green indicator diode
- J Control buttons

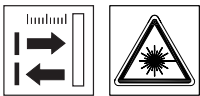

50 ... 450mm



- Large measurement range
- Reflection-independent distance information
- Highly insensitive to extraneous light
- IO-Link/OLED display and key pad for configuration
- Measurement value is indicated in mm on LC display
- Configurable measure mode and measurement range
- M12 turning connector

Electrical connection

ODSL 9/L-450-S12

18-30V DC +	1	br/BN
Do not connect	2	ws/WH
GND	3	bl/BU
I/O-Link Data	4	sw/BK
Do not connect	5	gr/GY

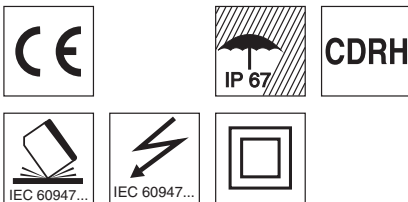

Accessories:

(available separately)

- Mounting systems
- Cable with M12 connector (K-D ...)
- IO-Link master set MD12-US2-IOL1 (50112085) and K-DS M12A-M12A-4P-2m-PVC cable (50110126)

We reserve the right to make changes • DS\_ODSL9L450\_en\_50118551.fm

## Specifications

### Optical data

Measurement range <sup>1)</sup>	50 ... 450mm
Resolution	0.1mm
Light source	laser
Wavelength	655nm
Light spot	divergent, 1x1mm <sup>2</sup> at 450mm
Max. output power	1.2mW
Pulse duration	22ms

### Error limits (relative to measurement distance)

Absolute measurement accuracy <sup>1)</sup>	± 1%
Repeatability <sup>2)</sup>	± 0.5%
B/W detection thresh. (6 ... 90% rem.)	≤ 0.5%
Temperature compensation	yes <sup>3)</sup>

### Timing

Measurement time <sup>4)</sup>	2ms <sup>1)</sup>
Response time	≤ 6ms
Delay before start-up	≤ 300ms

### Electrical data

Operating voltage U <sub>B</sub>	18 ... 30V (incl. residual ripple)
Residual ripple	≤ 15% of U <sub>B</sub>
Open-circuit current	≤ 180mA

### Sensor operating mode

IO-Link	COM2 (38.4kBaud), Frame 2.2, Vers. 1.0, min. cycle time 2.2ms
SIO	not supported

### Indicators

Green LED	continuous light	ready
	off	no voltage
Yellow LED	continuous light	object within measurement range
	off	no object within measurement range

### Mechanical data

Housing	plastic
Optics cover	glass
Weight	approx. 50g
Connection type	M12 connector, 5-pin

### Environmental data

Ambient temp. (operation/storage)	-20°C ... +50°C / -30°C ... +70°C
Protective circuit <sup>5)</sup>	1, 2, 3
VDE safety class <sup>6)</sup>	II, all-insulated
Protection class	IP 67
Laser class	2 (according to EN 60825-1 and 21 CFR 1040.10 with Laser Notice No. 50)
Standards applied	IEC 60947-5-2

- 1) Luminosity coefficient 6% ... 90%, complete measurement range, "Standard" operating mode, at 20°C, medium range of U<sub>B</sub>, measurement object ≥ 50x50mm<sup>2</sup>  
 2) Same object, identical environmental conditions, measurement object ≥ 50x50mm<sup>2</sup>  
 3) Typ. ± 0.02 %/K  
 4) internal measurement time distance sensor  
 5) 1=transient protection, 2=polarity reversal protection, 3=short circuit protection for all outputs  
 6) Rating voltage 50VAC

## Order guide

	Designation	Part no.
IO-Link interface	ODSL 9/L-450-S12	50111166

## Tables

## Diagrams

## Remarks

- Measurement time depends on the reflectivity of the measurement object and on the measurement mode.
- **Approved purpose:**  
This product may only be used by qualified personnel and must only be used for the approved purpose. This sensor is not a safety sensor and is not to be used for the protection of persons.

## ODSL 9

## Optical laser distance sensors

### IO-Link process data

#### Output data device

Data bit															
A15	A14	A13	A12	A11	A10	A9	A8	A7	A6	A5	A4	A3	A2	A1	A0
MSB	16 bit measurement value														LSB

16 bit measurement value: distance

1 bit output resolution: 0.1 mm

Signal too weak: 65535

Laser error: 65533

## IO-Link service data

Sensors with IO-Link interface can be configured and diagnosed via the service data.

### Parameters

#### Measure mode

A measurement mode for adapting to the application task can be activated with this parameter.

There is a selection of four measurement modes (standard, precision, speed und light suppression). By selecting the mode, the following results are achieved:

- **Standard:** standard setting
- **Precision:** high accuracy, approx. 95 % slower
- **Speed:** fast measurement, approx. 30 % faster
- **Light suppression:** higher immunity against external light interference

The following table provides an overview of the effects of the individual parameters on the measurement function.

Measure mode	Accuracy	Measurement time / update	Ambient light	Varying diffuse reflection
<b>Standard</b>	+	+	+	+
<b>Precision</b>	++	--	+	+
<b>Speed</b>	-	++	+	+
<b>Light suppression</b>	+	--	++	0

#### Measurement filter

A measurement filter for adapting to the application task can be activated with this parameter.

There is a selection of three options (off, averaging, center value). By selecting the filter, the following results are achieved:

- **Off:** no filtering of the measurement values.
- **Averaging:** a moving average from the last 2 ... 99 measurement values (setting of the number with `measurement_count`) is calculated and output. If the measurement value changes abruptly, the output value moves linearly over `n` measurements from the old to the new measurement value. The time until the measurement value is updated is therefore not affected by the number of measurements; the response time for distance changes slows down.
- **Center value:** filtering out of extreme values - the average is calculated from 10 ... 50 individual measurements. The number of individual measurements used for this purpose is selected via `measurement_count` (10, 20, 30, 40 or 50). The setting under `filter_depth` specifies whether only the most extreme (`coarse`), the middle (`medium`) or the lowest deviations (`fine`) should be filtered out.

The following table provides an overview of the effects of the individual parameters on the measurement function.

	Updating measurement time	Response time for small change in distance	Response time for large change in distance	Filtering of individual faulty measurements	Filtering of cumulative faulty measurements
<b>Off</b>	+	+	+	--	--
<b>Averaging</b>	+	-	-	0	-
<b>Center value</b>	--	-	-	++	+

#### Number of measurement values (averaging)

This parameter defines the number of individual measurements which are used for filtering.

#### Number of measurement values (center value)

This parameter defines the number of individual measurements which are used for filtering.

#### Filter depth (center value)

This parameter defines the filter gauge (medium, coarse, fine).

#### Display

This parameter determines the display setting on the sensor (on, off, auto).

#### Button lock

This parameter determines whether the key pad on the sensor is locked or activated.

**System commands:*****Laser transmitter activation***

This system command switches on the laser transmitter.

***Laser transmitter deactivation***

This system command switches off the laser transmitter.

If the sensor is deactivated, the last measurement value detected is frozen. The state of the laser can be seen from the sensor status.

***Setting to factory setting***

This system command restores the factory settings of the sensor.

**Diagnostics (observation)*****Signal too weak [process value 65535] or laser failure [process value 65533]***

Reception signal is not sufficient: either no object is in the measurement range or the signal from the object is too weak for detection. A displayed laser failure signalizes interference of the laser light source.

***Signal warning***

Low reception signal: the object is not detected reliably, e.g. because the signal from the object is very weak.

***Laser activation***

Status information on whether the laser transmitter is activated or deactivated.

***Measurement range sensor***

Status information on whether an object is located in the measurement range of the sensor.

***Notice!***

*If parameters are changed on the device via the display and keyboard, the master is not signaled. In the event the master sends an explicit request, however, the changed value is available.*

***Notice!***

*Detailed information about the IO-Link service data and the IODD can be found at [www.leuze.com](http://www.leuze.com).*

## Working safely



### **Attention Laser Radiation!**

**The ODSL 9 optical distance sensors operate with a red light laser of class 2 acc. to EN 60825-1. If you look into the beam path over a longer time period, the retina of your eye may be damaged!**

**Never look directly into the beam path! Do not point the laser beam of the ODSL 9 at persons!**

**When mounting and aligning the ODSL 9 take care to avoid reflections of the laser beam off reflective surfaces!**

**The use of operating and adjusting devices other than those specified in the technical description, carrying out of differing procedures, or improper use of the optical laser distance sensor may lead to dangerous exposure to radiation!**

**The use of optical instruments or devices in combination with the device increases the danger of eye damage!**

**Adhere to the applicable legal and local regulations regarding protection from laser beams acc. to EN 60825-1 in its latest version.**

**The ODSL 9 uses a laser diode with low power in the visible red light range with an emitted wavelength of about 655nm.**

**The glass lens cover is the only opening through which the laser radiation can escape from the device. The housing of the ODSL 9 is sealed and has no parts that need to be adjusted or maintained by the user. The device must not be tampered with and must not be changed in any way! Unauthorized opening of the device voids the warranty!**



### **Notice!**

**It is important to attach the stick-on labels delivered with the device (notice signs)! If the signs could be covered due to the installation location of the ODSL 9, attach them close to the ODSL 9 so that it is not possible to look into the laser beam when reading the notices!**