

rotoScan ROD4... plus

Laser scanner

en 07-2015/07 50108253-01



Dimensioned drawing

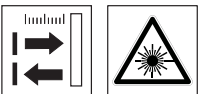
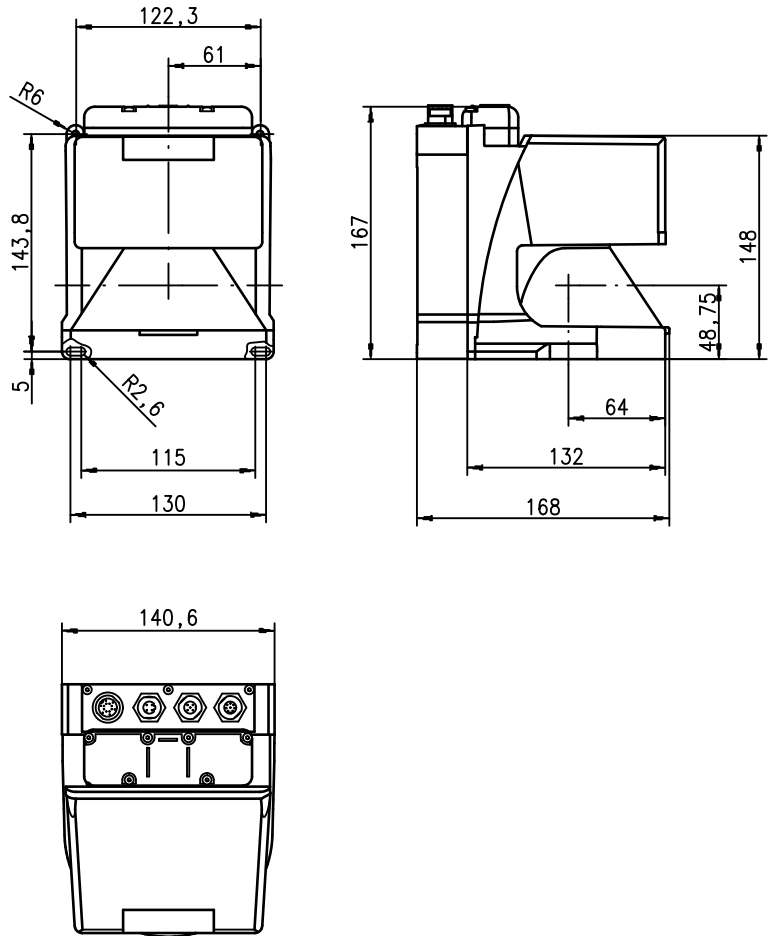

0 ... 65m



- Measurement data transmission via Fast Ethernet 100MBit/s
- Measurement data transmission via RS 232/422 serial interface
- Measurement data reduction, measurement data processing, measurement data filtering and determination of extreme values in the interface box
- Several device versions:
 - with/without heating, dust-insensitive version
 - scanning rate 50Hz, for object measurement
 - scanning rate 25Hz, for object detection and object measurement
 - measurement range 25m or 65m
- Service interface for configuration
- **ROD4 plus and ROD4-08 plus:** 7 storable and reversible detection fields for object detection
- Software:
 - RODplussoft:** Configuring measurement applications
 - RODsoft:** Configuring detection fields

Measurement principle

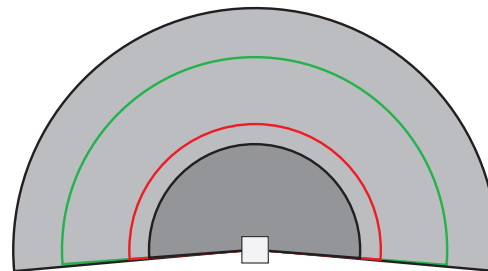
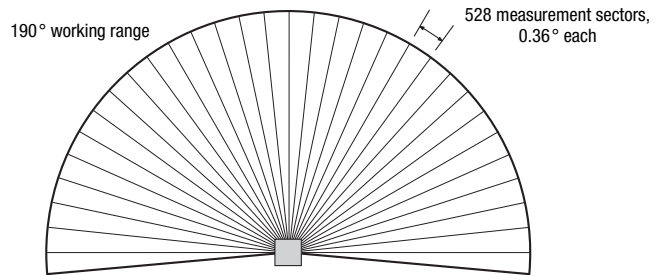

- ROD4 plus, ROD4-50 plus, ROD4-56 plus: Measurement range max. 65m
- ROD4-08 plus, ROD4-58 plus: Measurement range max. 25m
- Radius of far detection field: max. 50m
- Radius of near detection field: max. 30m



Accessories:

(available separately)

- Mounting system
- Configuration software RODplussoft and RODsoft (free download from www.leuze.de)
- Various connection cables

We reserve the right to make changes • DS_ROD4plus_en_50108253_01.fm

Specifications

Optical data

Measurement range	ROD4 plus, ROD4-50 plus, ROD4-56 plus: 0 ... 65m ROD4-08 plus, ROD4-58 plus: 0 ... 25m
Radius of detection field ¹⁾	near: 0 ... 30m far: 0 ... 50m
Scanning angle	max. 190°
Angular resolution	0.36°
Scanning rate	ROD4-5x plus: 50 scans/s or 20ms/scan ROD4 plus, ROD4-08 plus: 25 scans/s or 40ms/scan
Transmitter	Infrared laser diode
Wavelength	905nm
Impulse duration	3ns
Max. output power (peak)	15W

Object measurement

Reflectivity	from min. 1.8% (matte black) ROD4-x8 plus from 6% (dark gray)
Object size	> 20mm at distance of 4m > 100mm at distance of 15m
Response time	ROD4-5x... plus: at least 20ms (corresponds to 1 scan) ROD4 plus, ROD4-08 plus: at least 40ms (corresponds to 1 scan)
Switching inputs	4x +24VDC (FPS1 ... 4 at Y1 for switching between detection fields) additional restart input at Y1 and interface box
Switching outputs	4x PNP transistor outputs 24V/250mA (Alarm, Warn, Near field 1, Near field 2)
Measurement value resolution per sector	5mm
Repeatability ²⁾	ROD4 plus, ROD4-50 plus, ROD4-56 plus: ± 15mm ROD4-08 plus, ROD4-58 plus: ± 20mm

Object detection (ROD4 plus, ROD4-08 plus)

Reflectivity	from min. 1.8% (matte black) ROD4-08 plus from 6% (dark gray)
Object size	> 20mm at distance of 4m > 100mm at distance of 15m
Response time	at least 40ms (corresponds to 1 scan)
Number of detection field pairs	7 (selectable via switching inputs)
Switching inputs	4x +24VDC (FPS1 ... 4 at Y1 for switching between detection fields) additional restart input at Y1 and interface box
Switching outputs	4x PNP transistor outputs 24V/250mA (Alarm, Warn, Near field 1, Near field 2)

Electrical data

Voltage supply ³⁾	+24VDC +20% / -30%
Overcurrent protection	fuse 2.5A (4A with heating) semi time-lag in the switch cabinet
Current consumption	approx. 1A (use power supply with 2.5A), approx. 4A with heating
Power consumption	< 75W at 24V including the outputs
Overvoltage protection	overvoltage protection with protected limit stop

Mechanical data

Housing	diecast aluminum, plastic
Weight	2.3kg
Connection type	4 connectors (can be plugged from above)

Environmental data

Ambient temp. (operation/storage)	-0°C ... +50°C/-20°C ... +50°C -20°C ... +50°C/-20°C ... +50°C (with heating)
VDE safety class	III, protective extra-low voltage
Degree of protection	IP 65
Laser class	1 (acc. to IEC 60825-1:2007 and 21 CFR 1040.10 with Laser Notice No. 50)
Standards applied	IEC 60947-5-2
Certifications	UL 508, C22.2 No.14-13 ³⁾

1) Only applies for ROD4 plus, ROD4-08 plus
2) 10 ... 90% diffuse reflection, at operating range of 4m
3) Protective Extra Low Voltage (PELV) - protective extra-low voltage with reliable disconnection.
For UL applications: only for use in class 2 circuits according to NEC.

Order guide

	Designation	Part no.
For object detection / object measurement, scanning rate 25scans/s		
	ROD4 plus	50106481
With heating/dust-insensitive	ROD4-08 plus	50106480
For object measurement, scanning rate 50scans/s		
	ROD4-50 plus	50113226
With heating	ROD4-56 plus	50129795
With heating/dust-insensitive	ROD4-58 plus	50113225

Remarks

Intended use:

The laser scanners are optical electronic sensors for optical, contactless detection of objects.

Operate in accordance with intended use!

- ⚠ This product is not a safety sensor and is not intended as personnel protection.
- ⚠ The product may only be put into operation by competent persons.
- ⚠ Only use the product in accordance with the intended use.

"RODplussoft" configuration software

The configuration software runs under Windows 2000/XP and offers the following features:

- Configuration of Ethernet and serial interface
- Configuration of up to 12 measurement segments
- Visualization of measurement values

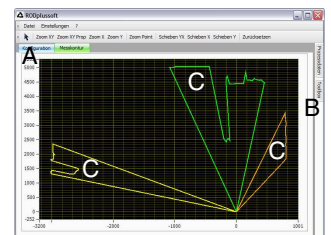

- A Configuration of the data transmission in the "Configuration" tab
- B Definition of measurement segments in the "Toolbox"
- C Graphical display of the measurement values of the measurement segments in various colors

- Transfer of measurement values in XY coordinates or polar coordinates.

Configuration software "RODsoft" (for ROD4-(08) plus only)

- Definition of the detection fields
- Configuration of the scanner parameters
- Visualization of the detection fields and measurement values
- Display of status/diagnostic information
- Support of various languages

Electrical connection - Assignment connector

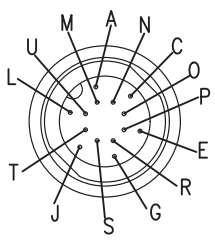
Y1 Logic		
		
Pin	Function	Color
A	+U _B	rd (red)
C	GND_IN	bu (blue)
E	FPS1	pi (pink)
G	FPS2	gr (gray)
J	FPS3	ye (yellow)
L	FPS4	gn (green)
M	Restart_IN	br (brown)
N	Near field 1	wh (white)
O	Near field 2	vi (violet)
P	Alarm	bl (black)
R	Warn	wh-gn (white-green)
S	NC	
T	NC	
U	NC	

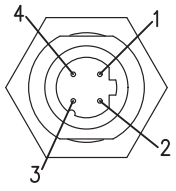
Y2 Ethernet		
		
Pin	Function	Color
1	Tx+	ye
2	Rx+	wh
3	Tx-	or (orange)
4	Rx-	bu

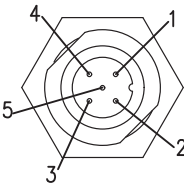
Y3 Service		
		
Pin	Function	Color
1	NC	
2	TxD	wh
3	GND	bu
4	RxD	bl
5	NC	

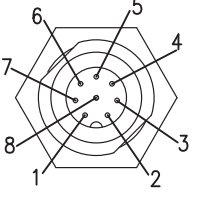
Y4 RS 232/422		
		
Pin	Function	Color
1	TX+ / TxD	wh
2	Tx-	br
3	Rx-	gn
4	Rx+ / RxD	ye
5	GND/shield	gr
6	RS 422 detection	pi
7	NC	
8	NC	

Installing the software RODplussoft

The **RODplussoft** configuration software is used for configuring the interfaces and the measurement functions of all of the ROD4... plus. The **RODplussoft** configuration software can be found on the supplied CD. To install, follow the instructions in the respective readme files, which can likewise be found on the supplied CD.

You can also download the respective, latest version of **RODplussoft** from www.leuze.com.

Unzip the ZIP file supplied into a suitable folder on your hard disk.

- ☞ Start the installation by double-clicking on the `setup.exe` file.
- ☞ Follow the instructions of the installation routine.

Notice!

Before installing **RODplussoft**, ensure that Microsoft® .NET Framework 2.0 SP1 or later is installed on your computer.

Install the RODsoft software (for ROD4 plus and ROD4-08 plus only)

You have to install the **RODsoft** software only if you wish to create detection fields for laser scanners of type ROD4 plus or ROD4-08 plus.

Notice!

With **ROD4-5... plus** laser scanners, status and diagnostic information can be called up using **RODsoft**.

The **RODsoft** configuration software can be found on the supplied CD. To install, follow the instructions in the respective readme files, which can likewise be found on the supplied CD.

You can also download the respective, latest version of **RODsoft** from www.leuze.com.

Unzip the ZIP file supplied into a suitable folder on your hard disk.

- ☞ Start the installation by double-clicking on the `setup.exe` file.
- ☞ Follow the instructions of the installation routine.

Establish connection to PC

The ROD4... plus is configured via a PC using the **RODplussoft** program, before it is integrated into the process control.

In order to be able to establish a TCP communication with the PC, the IP address of your PC and the IP address of the ROD4... plus must lie in the same address range. The ROD4... plus has no built-in DHCP client, so you need to set the address manually. The easiest way to do this is via the PC.

The ROD4... plus is set ex works as follows:

IP address: 192.168.060.003
Subnet mask: 255.255.255.0



Notice!

If you are using a desktop firewall, please ensure that the control can communicate with the ROD4... plus via the Ethernet interface on ports 9008 and using TCP. Furthermore, the firewall must allow ICMP echo messages to pass through for the connection test (ping).

If the PC is usually connected to a network using DHCP address allocation, the easiest way to access the ROD4... plus is by applying an alternative configuration in the TCP/IP settings of the PC and connecting the ROD4... plus directly to the PC.

According to the default setting of 255.255.255.0 for the subnet mask, the IP address of the PC must then lie in the range 192.168.060.0 to 192.168.060.255 (e.g., 192.168.060.110, but not 192.168.060.003!), so that ROD4... plus and PC can communicate with each other. If ROD4... plus and the PC have the same IP address, they cannot communicate with each other.

Configuring the IP address for a PC

- ☞ Log in to your PC as an administrator.
- ☞ Using Start->System control go to the Network connections (Windows XP) menu or to the Network center and release center (Windows 7) menu.
- ☞ There, select *Local Area Connection* and right-click to open the corresponding properties page.
- ☞ Select the Internet Protocol (TCP/IP) (by scrolling down, if necessary) and click on Properties.
- ☞ In the Internet Protocol (TCP/IP) Properties window select the Alternate configuration tab.
- ☞ Set the IP address of the PC in the address range of the ROD4... plus. **Attention:** not the same as for the ROD4... plus!
- ☞ Set the Subnet mask of the PC to the same value as the one for the ROD4... plus.
- ☞ Close the configuration dialog by confirming all windows using OK.
- ☞ *Connect the Y2 interface of the ROD4... plus directly to the LAN port of your PC.* Use a **KB ET-...-SA-RJ45** cable for the connection.

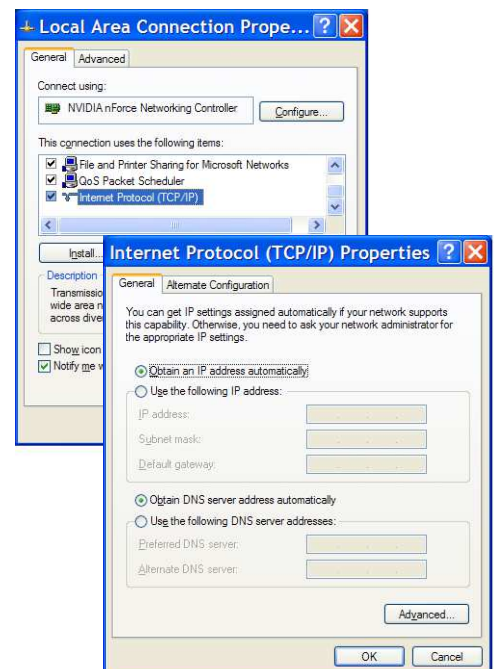

Laser safety notices – laser class 1



ATTENTION, LASER RADIATION – LASER CLASS 1

The device fulfills the EN 60825-1:2007 safety regulations for a product in **laser class 1** as well as the U.S. 21 CFR 1040.10 regulations with deviations corresponding to "Laser Notice No. 50" from June 24th, 2007.

- ↪ Adhere to the applicable legal and local regulations regarding protection from laser beams.
- ↪ The device must not be tampered with and must not be changed in any way.
 - There are no user-serviceable parts inside the device.
 - Repairs must only be performed by Leuze electronic GmbH + Co. KG.

Commissioning

- ↪ Switch on the supply voltage of the ROD4... plus.
- ↪ Start the software **RODplussoft**.

The PC first tries to establish a network connection via the automatic configuration using Ethernet. This takes a few seconds, after which the alternate configuration, which you just set, is activated. The PC can then communicate with the ROD4... plus via Ethernet.

Further information about configuring the ROD4... plus using **RODplussoft** software can be found in the Technical Description and Software and Protocol Description.

For the commissioning and integration of the laser scanner in the process control the following steps are necessary:

1. Configure the ROD4... plus - see chapter 6 of the Technical Description.
2. Configure, if necessary, detection fields with the **RODsoft** configuration software (Configuration -> Start RODsoft... menu item) (**for ROD4 plus and ROD4-08 plus only!**). See section **Configuring detection fields**.
3. Program process control.
 - or
4. Connect the switching inputs and outputs accordingly - see chapter 5 of the Technical Description.
5. Adapt the IP configuration of the ROD4... plus such that it can communicate with the process control. This occurs in **RODplussoft** in the **Communication** tab. Here you can change the network address and the corresponding net mask, via which the ROD4... plus communicates with the process control.

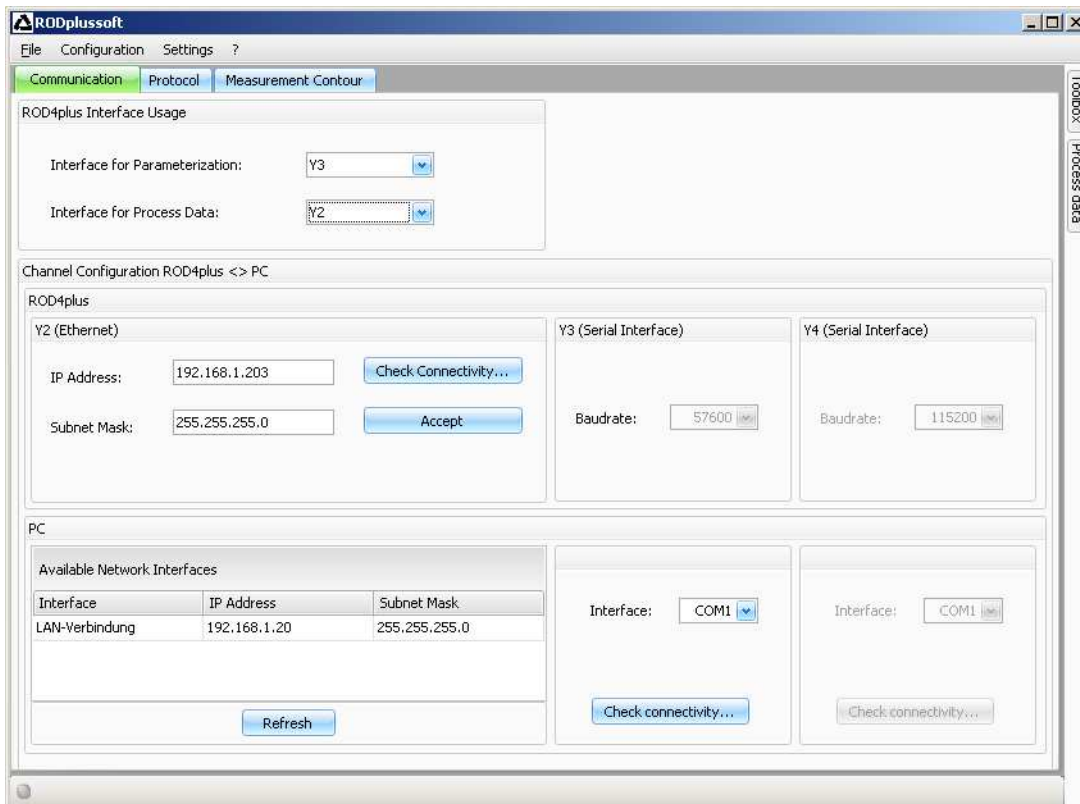

6. Save the changed settings in the ROD4... plus using the Configuration -> Transmit to ROD4plus menu item.
7. Connect ROD4... plus to process control via the Ethernet interface Y2.

Configure the detection fields (for ROD4 plus and ROD4-08 plus only)

Commissioning procedure:

- ☞ Connect the PC via the **KB-ROD4plus...** cable at the connection **Y3 - Service** to the ROD4(-08) plus.
- ☞ From **RODplussoft** start the **RODsoft** configuration software via the **Start RODsoft...** menu item.
- ☞ Enter the password "**ROD4LE**" in the level "Authorized User".

The detection field can be displayed under "Display measurement contour". Under "ROD4 configuration" the response times, the detection field switches and other parameters are defined. To configure the detection fields, select the "Define detection areas" field. Error codes and other information are contained in the ROD4 system data.

A detailed description can be found in the user manual for the **RODsoft** configuration software.

