



IPRK 95

Retro-reflective photoelectric sensors with polarisation filter



0 ... 6m



- Polarised retro-reflective photoelectric sensor using visible red light
- High switching frequency for detection of fast events
- The autocollimation principle used ensures that the device functions reliably over the entire range (0 ... max.)
- Activation input for testing and interlinking

Dimensioned drawing

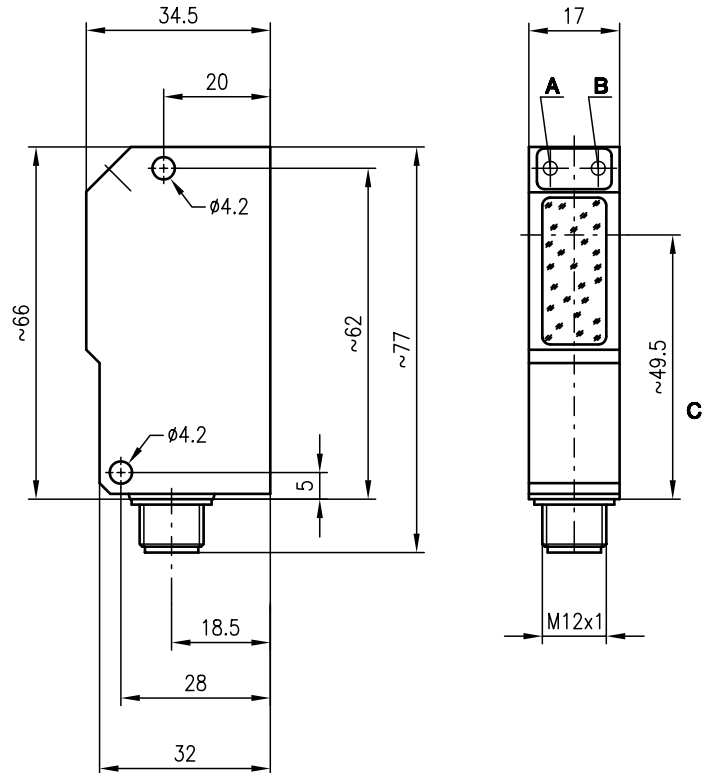

- A Switching indicator yellow
- B Operation indicator green
- C Optical axis

Electrical connection

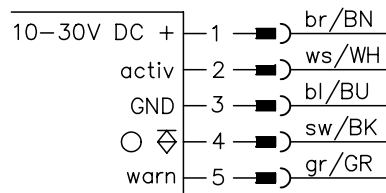

Accessories:

(available separately)

- Mounting systems (BT 95, UMS 1, UMS 96-95)
- M12 connectors (KD ...)
- Reflectors
- Reflective tapes

We reserve the right to make changes • 95_b03e.fm

Specifications

Optical data

Typ. operating range limit (TK(S) 100x100) ¹⁾	0 ... 6m
Operating range ²⁾	see tables
Light beam characteristic	divergent
Light source	LED (modulated light)
Wavelength	660nm (visible red light, polarised)

Timing

Switching frequency	1000Hz
Response time	0.5ms
Delay before start-up	≤ 100ms

Electrical data

Operating voltage U_B	10 ... 30VDC (incl. residual ripple)
Residual ripple	≤ 15% of U_B
Bias current	≤ 35mA
Switching output	1 PNP transistor output
Function characteristics	light switching
Signal voltage high/low	≥ ($U_B - 2V$) / ≤ 2V
Output current	max. 100mA

Indicators

LED green	ready
LED yellow	light path free
LED yellow flashing	light path free, no performance reserve

Mechanical data

Housing	diecast zinc
Optics cover	glass
Weight	90g
Connection type	M12 connector, stainless steel, 5-pin

Environmental data

Ambient temp. (operation/storage) ³⁾	-25°C (-30°C) ... +55°C / -40°C ... +55°C
Protective circuit ⁴⁾	2, 3
VDE safety class ⁵⁾	II, all-insulated
Protection class	IP 67, IP 69K ⁶⁾
LED class	1 (acc. to EN 60825-1)
Standards applied	IEC 60947-5-2

Options

Activation input activ	
Transmitter active/not active	≥ 8V / ≤ 2V or not connected
Activation/disable delay	≤ 1ms
Input resistance	4.7kΩ ± 10%
Warning output autoControl warn	
Signal voltage high/low	PNP transistor, counting principle
Output current	≥ ($U_B - 2V$) / ≤ 2V max. 100mA

- 1) Typ. operating range limit: max. attainable range without performance reserve
- 2) Operating range: recommended range with performance reserve
- 3) -30°C with operating voltage continuously applied
- 4) 2=polarity reversal protection, 3=short-circuit protection for all outputs
- 5) Rating voltage 250 VAC
- 6) IP 69K test acc. to DIN 40050 part 9 simulated, high pressure cleaning conditions without the use of additives, acids and bases are not part of the test

Order guide

Designation	Part No.
IPRK 95/4.8 L.2	500 30257

Tables

Reflectors	Operating range
1 TK(S) 100x100	0 ... 4.2m
2 MTK(S) 50x50	0 ... 3.2m
3 TK(S) 30x50	0 ... 1.8m
4 TK(S) 20x40	0 ... 1.7m
5 Tape 2 100x100	0 ... 1.2m

1	0	4.2	6
2	0	3.2	5.4
3	0	1.8	3.0
4	0	1.7	2.9
5	0	1.2	1.7

Operating range [m]
 Typ. operating range limit [m]

TK ... = adhesive
 TKS ... = screw type
 Tape 2 = adhesive

Diagrams

Typ. response behaviour (TK 100x100)

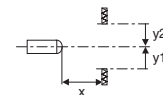
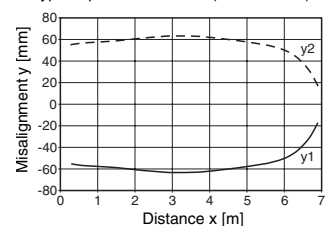

Remarks