

Varioprint fuse module

Identification	Type	SIPE 4-0821 24 V 4×4 A
	Part-No.	710821

Description	DC Load monitoring with thermal fuse, resettable	
	4 monitoring circuits 4 A / 8 A	
	Group signal using potential-free relay contact, optical single-channel signal	

Input		
Nominal voltage	DC 24 V	
Input voltage range	16.8 V – 30.0 V	
Rated current	4 × DC 4 A (max. 10 × I _N)	
Fuse	circuit breaker with thermal tripping characteristic	
Resistor	(interior) <0.1 Ω	
Status Indication	4 × LED green	
Rated insulation voltage (EN 50178)	50 V	
Reverse voltage protection	4 × LED green	
Termination	Screw terminal	

Signal circuit		
Contact type	1 change over contact	
Min. switching voltage	AC/DC 17 V	
Max. switching voltage	AC/DC 250 V	

05.03.2014 – Subject to technical modification

Part-No. 710821

USA: LUTZE INC.
 13330 South Ridge Drive • Charlotte, NC 28273, USA
 Tel. +1 (704) 504-0222 • Fax +1 (704) 504-0223
 www.lutze.com • info@lutze.com

United Kingdom: LÜTZE Ltd.
 Unit 3, Sandy Hill Park
 Sandy Way, Amington • GB-Tamworth, Staffs B77 4DU
 Tel. +44 (0)1827 31333-0 • Fax +44 (0)1827 31333-2
 www.lutze.com • sales.gb@lutze.co.uk



SYSTEMATIC TECHNOLOGY

Technical data sheet - Load monitoring

Min. switching current	AC/DC 0.10 mA
Max. switching current	AC/DC 3 A
Switch-on delay	8 ms
Switch-off delay	8 ms
Switching capacity	max. 2000 VA
Contact material	AgNi + 0.15 HV
Mechanical service life	2×10^7 operations
Rated insulation voltage (EN 40178)	300 V
Clearance/creep. dist. (control/load side)	>2 mm

Load Side

Switching element	Relay
-------------------	-------

General

Operation temperature range	-20 °C – 60 °C
Storage temperature range	-25 °C – 80 °C
Dimensions (w × h × d)	65.0 × 77.0 × 48.0 mm
Field installation	rail TS 35 (EN 50022)
Protection class	IP 20
Weight (kg/piece)	0.098
Termination	Screw terminal: 0.25–2.5 mm ²
Form	Varioprint
Operation temperature range	-20 °C – 60 °C

05.03.2014 – Subject to technical modification

Part-No. 710821

USA: LUTZE INC.

13330 South Ridge Drive • Charlotte, NC 28273, USA
Tel. +1 (704) 504-0222 • Fax +1 (704) 504-0223
www.lutze.com • info@lutze.com

United Kingdom: LÜTZE Ltd.

Unit 3, Sandy Hill Park
Sandy Way, Amington • GB-Tamworth, Staffs B77 4DU
Tel. +44 (0)1827 31333-0 • Fax +44 (0)1827 31333-2
www.lutze.com • sales.gb@lutze.co.uk



SYSTEMATIC TECHNOLOGY

Dimensions

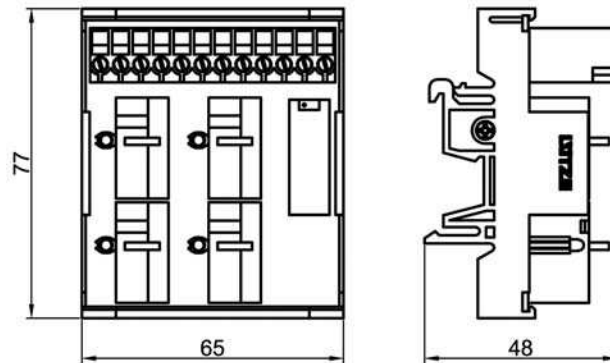

PIN assignment

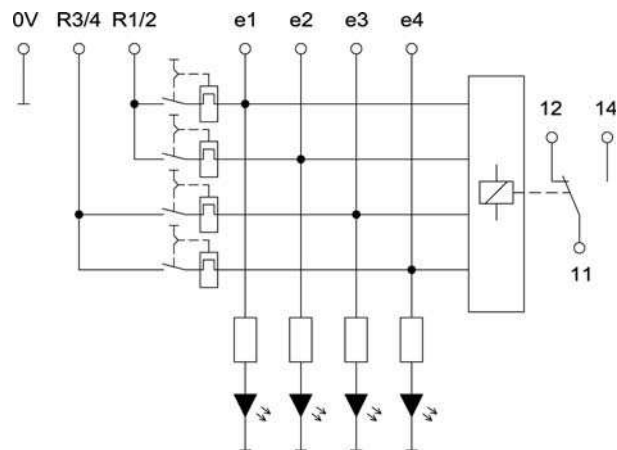

Comments

Hard gold-plated contacts: So that the gold layer is not damaged, the specified values should not be exceeded. At higher switching capacity, the gold layer vaporizes. The deposition in the housing can lead to sparkovers between the coil and contact.

05.03.2014 – Subject to technical modification

Part-No. 710821

USA: LUTZE INC.

13330 South Ridge Drive • Charlotte, NC 28273, USA
Tel. +1 (704) 504-0222 • Fax +1 (704) 504-0223
www.lutze.com • info@lutze.com

United Kingdom: LÜTZE Ltd.

Unit 3, Sandy Hill Park
Sandy Way, Amington • GB-Tamworth, Staffs B77 4DU
Tel. +44 (0)1827 31333-0 • Fax +44 (0)1827 31333-2
www.lutze.com • sales.gb@lutze.co.uk



SYSTEMATIC TECHNOLOGY