



Identification	Type	WNAA 7-0539
	Part-No.	750539

Input

	0/10 V	0–20 mA	4–20 mA
Input resistance	330 k Ω	100 Ω	100 Ω
Input signal	0–10 V, 0–20 mA, 4–20 mA, adjustable via switch		
Galvanic insulation I/O	3-way isolation		
Zero /Span	Production comparison		
Transmission frequency	30 Hz at 3 dB		

Load Side

	0/10 V	0–20 mA	4–20 mA
Max. load impedance at I-output		400 Ω	400 Ω
Max. load impedance at U-output	>1 k Ω		
Load impedance	55 Ω		
Output current	max. 21 mA		
Output signal	Adjustable via switch		
Ripple	<5 mV _{eff}		

General

26.11.2015 – Subject to technical modification

Part-No. 750539

USA: LUTZE INC.

13330 South Ridge Drive · Charlotte, NC 28273, USA
 Tel. +1 (704) 504-0222 · Fax +1 (704) 504-0223
 www.lutze.com · info@lutze.com

United Kingdom: LUTZE Ltd.

Unit 3, Sandy Hill Park
 Sandy Way, Amington · GB-Tamworth, Staffs B77 4DU
 Tel. +44 (0)1827 31333-0 · Fax +44 (0)1827 31333-2
 www.lutze.com · sales.gb@lutze.co.uk



SYSTEMATIC TECHNOLOGY

Technical data sheet • Interface Technology

Nominal voltage	AC/DC 24 V
Operation voltage range	DC: 16,8–30 V, AC: 19,2–28,8 V
Rated current	13.0 mA
Input/output protection	AC/DC 30 V overvoltage, current input with PTC, short circuit-proof output
Accuracy	0.1 % FSR (23 °C)
Linearity error	0.10 %
Rise time (10 - 90%)	10 ms
Build-up time (Accuracy 1%)	30 ms
Transmission frequency	<30 Hz
Temperature coefficient	<150 ppm / K FSR
Insulation voltage input/output	1.5 kV _{eff}
Housing material	PA 6.6 (UL 94 V-0)
Field installation	rail TS 35 (EN 50022)
Protection class	IP 20
Installation position	Optional
Termination	screw terminal: 0.14–1.5 mm ²
Operation temperature range	-25 °C – 60 °C
Storage temperature range	-40 °C – 85 °C
Dimensions (w × h × d)	6.2 × 90.0 × 92.5 mm
Weight (kg/piece)	0.040 kg/piece
Approvals	cULus, Class I, Div. 2, Groups A, B, C, D T4A

Dimensions

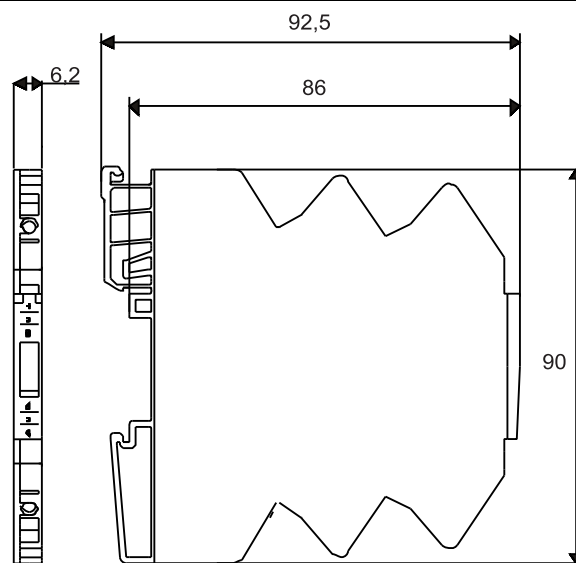

26.11.2015 – Subject to technical modification

Part-No. 750539

USA: LUTZE INC.

13330 South Ridge Drive • Charlotte, NC 28273, USA

Tel. +1 (704) 504-0222 • Fax +1 (704) 504-0223

www.lutze.com • info@lutze.com

United Kingdom: LUTZE Ltd.

Unit 3, Sandy Hill Park

Sandy Way, Amington • GB-Tamworth, Staffs B77 4DU

Tel. +44 (0)1827 31333-0 • Fax +44 (0)1827 31333-2

www.lutze.com • sales.gb@lutze.co.uk



SYSTEMATIC TECHNOLOGY

Technical data sheet · Interface Technology

PIN assignment

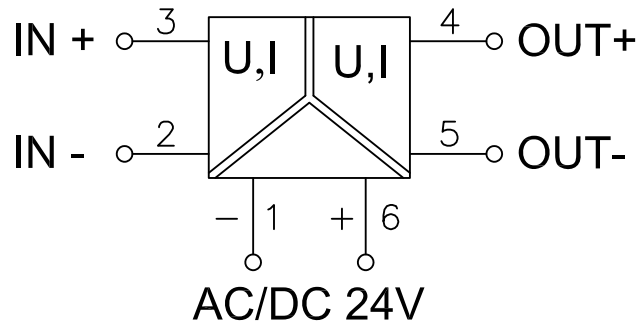

Range adjustment

● → SwitchOn		S1					
Input	Output	1	2	3	4	5	6
0-20mA	0-10V	●					
0-20mA	0-20mA	●	●				
0-20mA	4-20mA	●					
4-20mA	0-10V	●		●			
4-20mA	0-20mA	●	●				
4-20mA	4-20mA	●	●				
0-10V	0-10V		●	●			
0-10V	0-20mA		●	●			
0-10V	4-20mA		●	●			

Accessories

Accessories	Color	Article number	Type	PU
Tag holder 4×11 mm	white	681313	BZT-0411	100
Isolation plate		760809	TP 7-0809	5

Accessories

Accessories	Color	2-pole	3-pole	4-pole	8-pole	16-pole	PU
6 A jumper comb	red	762802	762805	762812	762822	762832	10
6 A jumper comb	white	762803	762806	762813	762823	762833	10
6 A jumper comb	blue	762804	762807	762814	762824	762834	10

26.11.2015 – Subject to technical modification

Part-No. 750539

USA: LUTZE INC.

13330 South Ridge Drive · Charlotte, NC 28273, USA

Tel. +1 (704) 504-0222 · Fax +1 (704) 504-0223

www.lutze.com · info@lutze.com

United Kingdom: LUTZE Ltd.

Unit 3, Sandy Hill Park

Sandy Way, Amington · GB-Tamworth, Staffs B77 4DU

Tel. +44 (0)1827 31333-0 · Fax +44 (0)1827 31333-2

www.lutze.com · sales.gb@lutze.co.uk



SYSTEMATIC TECHNOLOGY