



| | | |
|-----------------------|---|------------------------------------|
| Identification | Type Part-No. | LCR-PW-3-480-D-2U-24-240 750680 |
| Description | Load sensor 1 and 3-phase loads AC 480 V | |
| Function | | |

25.08.2017 – Subject to technical modification

Part-No. 750680

USA: LUTZE INC.

13330 South Ridge Drive • Charlotte, NC 28273, USA
Tel. +1 (704) 504-0222 • Fax +1 (704) 504-0223
www.lutze.com • info@lutze.com

United Kingdom: LÜTZE Ltd.

Unit 3, Sandy Hill Park
Sandy Way, Amington • GB-Tamworth, Staffs B77 4DU
Tel. +44 (0)1827 31333-0 • Fax +44 (0)1827 31333-2
www.lutze.com • sales.gb@lutze.co.uk

Technical data sheet · Interface Technology

| | |
|----------|---|
| Function | True power monitoring for 1 and 3-phase loads with 48 settable thresholds (P1, P2) separately adjustable start-up suppression and trigger delay selectable error memory Temperature monitoring of the motor coil with max. 6 PTC One reset button; function selection via rotary switch 2MIN: Minimum monitoring 2MIN+I< ON: Minimum monitoring and recognition of shut-down consumers as GOOD status 2MIN+I< Inv: Minimum monitoring and recognition of shut-down consumers as errors 2MAX: Maximum monitoring 2MAX+I< ON: Maximum monitoring and recognition of shut-down consumers as errors 2MAX+I< Inv: Maximum monitoring and recognition of shut-down consumers as GOOD status WIN: Monitoring the range between thresholds Min and Max WIN+I< ON: Monitoring the range between the Min and Max thresholds and recognition of shut-down consumers as GOOD status WIN+I< Inv: Monitoring the range between the Min and Max thresholds and recognition of shut-down consumers as errors MAX/MIN: Maximum/minimum monitoring MAX/MIN+I< ON: Maximum/minimum monitoring and Monitoring the range and recognition of shut-down consumers as GOOD status MAX/MIN+I< Inv: Maximum/minimum monitoring and Monitoring the range and recognition of shut-down consumers as errors |
|----------|---|

Time range

| | |
|--------------------------------|------------|
| Start-up suppression, settable | 0 – 100 s |
| trigger delay, settable | 0.1 – 50 s |

Status indication

| | |
|-------------------------|--------------------|
| Supply status | LED green |
| Start bridge status | LED green flashing |
| Output relay status | LED yellow |
| Threshold error status | LED red |
| Trigger delay status | LED red flashing |
| Status I/O | LED yellow |
| Over-temperature status | LED red |

Housing

| | |
|------------------------|------------------------|
| Dimensions (w × h × d) | 45.0 × 90.0 × 105.0 mm |
| Colour of the housing | light grey |
| Housing material | PA 6.6 V0 |
| Protection class | IP20 |

25.08.2017 – Subject to technical modification

Part-No. 750680

USA: LUTZE INC.

13330 South Ridge Drive · Charlotte, NC 28273, USA
Tel. +1 (704) 504-0222 · Fax +1 (704) 504-0223
www.lutze.com · info@lutze.com

United Kingdom: LÜTZE Ltd.

Unit 3, Sandy Hill Park
Sandy Way, Amington · GB-Tamworth, Staffs B77 4DU
Tel. +44 (0)1827 31333-0 · Fax +44 (0)1827 31333-2
www.lutze.com · sales.gb@lutze.co.uk



SYSTEMATIC TECHNOLOGY

Technical data sheet · Interface Technology

| | |
|--------------------------|--|
| Connection cross-section | 1×0.5 to 2.5 mm ² with AE 1×4 mm ² without AE 2×0.5 to 1.5 mm ² with AE 2×2.5 mm ² without AE |
| Installation position | any |
| Weight | 0.400 kg/piece |
| Approvals | cULus |

Supply circuit

| | |
|---------------------------|---|
| Rated voltage range | AC/DC 24 V – 240 V |
| Tolerance | AC: -15 %/+10 %, DC: -20 %/+25 % |
| Rated frequency | 16 Hz @ AC 24 V, 48 Hz – 400 Hz @ AC 24 V – 240 V |
| Power consumption | 3.5 VA (3 W) |
| Operating time | 100 % ED |
| Recovery time | 500 ms |
| Voltage drop | >30 % of the supply voltage |
| Over voltage category | III acc. IEC 60664-1 |
| Measurement surge voltage | 4 kV |

Output circuit

| | |
|---------------------------|---------------------------------|
| Number of channels | 2 |
| Switching element | Relays |
| Contact type | Change over contact |
| Measurement voltage | AC 250 V |
| Switching voltage | AC 250 V |
| Switching current max. | 3A (5A at a distance >5mm) |
| Protection device | 5 A, quick-acting |
| Mechanical service life | 20 × 10 ⁶ (1000 VA) |
| Electrical service life | 2 × 10 ⁵ (1000 VA) |
| Switching frequency | 60/min @100 VA, 6/min @ 1000 VA |
| Over voltage category | III acc. IEC 60664-1 |
| Measurement surge voltage | 4 kV |

Accuracy

| | |
|----------------------|---------------------|
| Basic accuracy | ±2 % (end of scale) |
| Frequency response | ±0.025 %/Hz |
| Tolerance of setting | ≤5 % (end of scale) |
| Repeat accuracy | ≤2 % |
| Temperature error | ±0.02 %/°C |

Measuring circuit

| | |
|--------------------|--|
| Measuring variable | 0.75 kW, 1.5 kW, 3 kW, 6 kW reversible |
|--------------------|--|

25.08.2017 – Subject to technical modification

Part-No. 750680

USA: LUTZE INC.

13330 South Ridge Drive · Charlotte, NC 28273, USA
Tel. +1 (704) 504-0222 · Fax +1 (704) 504-0223
www.lutze.com · info@lutze.com

United Kingdom: LÜTZE Ltd.

Unit 3, Sandy Hill Park
Sandy Way, Amington · GB-Tamworth, Staffs B77 4DU
Tel. +44 (0)1827 31333-0 · Fax +44 (0)1827 31333-2
www.lutze.com · sales.gb@lutze.co.uk



SYSTEMATIC TECHNOLOGY

Technical data sheet · Interface Technology

| | |
|------------------------------------|---|
| Wave form AC Sinus | 10 – 400 Hz |
| Wave form PWM | 10 – 100 Hz (sine-assessed) |
| Measurement input 1-phase | AC 0 – 480 V |
| Measurement input 3-phase | 3ph 0 – 480/277 V |
| Overload capability | 550 V (1-phase), 550/318 V (3-phase) |
| Input resistance | 1.25 M Ω |
| Measurement input current, 1-phase | 0.15A – 6A (0.75 – 1.5 kW), 0.3 – 12 A (3 – 6 kW) |
| Overload capability current | 12 A permanent |
| Current interruption | 150 mA (0.75 – 1.5 kW), 180 mA (3 – 6 kW) |
| Current flow sensor | 300 mA (0.75 – 1.5 kW), 360 mA (3 – 6 kW) |
| Switching threshold P1 | 10 % – 120 % from P _N |
| Switching threshold P2 | 5 % – 110 % from P _N |
| Hysteresis | 1 % @ Maximum measuring range' |
| Over voltage category | III acc. IEC 60664-1 |
| Measurement surge voltage | 4 kV |

Temperature monitoring

| | |
|------------------------|--|
| Sum of cold resistance | <1.5 k Ω |
| Response value | \geq 3.6 k Ω (relay drops) |
| Drop-off value | \leq 1.8 kW (Relay is energised) |
| Line short-circuit | No shut-off |
| Measurement voltage | \leq 7.5 V at R \leq 4.0 kW (acc. IEC 60947-8) |

Control input

| | |
|--------------|------------------------------|
| Function | Fault store |
| Load | none |
| Cable length | 10 m max., twisted |
| Reset | NC contact in supply circuit |

Environmental conditions

| | |
|-----------------------------------|---|
| Temperature range according to UL | -25 °C ... +40 °C |
| Temperature range | -25 °C ... +55 °C |
| Storage temperature range | -25 °C ... +70 °C |
| Relative air humidity | 15 % to 85 % acc. IEC 60721-3-3 Class 3K3 |
| Degree of pollution | 3 |
| Vibration resistance | 10 – 55 Hz 0.35 mm acc. IEC60068-2-6 |
| Impact resistance | 15 g 11 ms acc. IEC 60068-2-27 |

25.08.2017 – Subject to technical modification

Part-No. 750680

USA: LUTZE INC.

13330 South Ridge Drive · Charlotte, NC 28273, USA

Tel. +1 (704) 504-0222 · Fax +1 (704) 504-0223

www.lutze.com · info@lutze.com

United Kingdom: LÜTZE Ltd.

Unit 3, Sandy Hill Park

Sandy Way, Amington · GB-Tamworth, Staffs B77 4DU

Tel. +44 (0)1827 31333-0 · Fax +44 (0)1827 31333-2

www.lutze.com · sales.gb@lutze.co.uk



SYSTEMATIC TECHNOLOGY

Dimensions

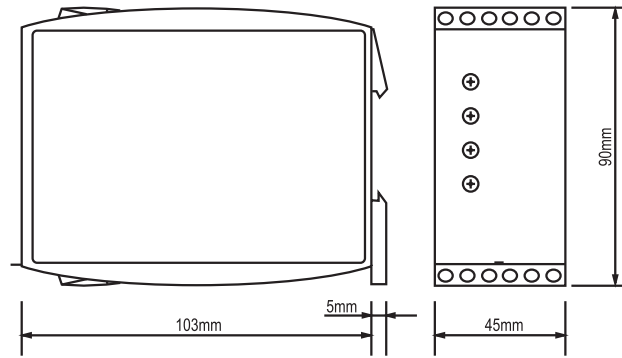

PIN assignment

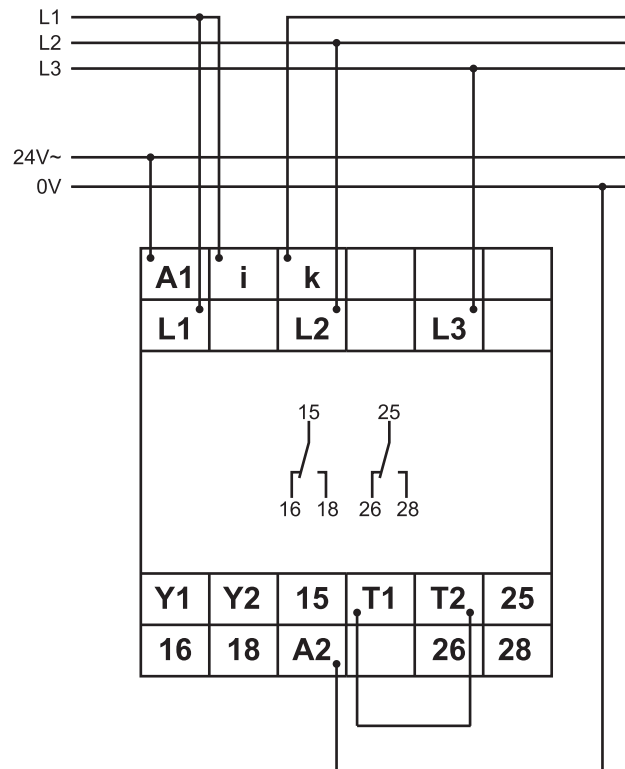

25.08.2017 – Subject to technical modification

Part-No. 750680

USA: LUTZE INC.

13330 South Ridge Drive • Charlotte, NC 28273, USA

Tel. +1 (704) 504-0222 • Fax +1 (704) 504-0223

www.lutze.com • info@lutze.com

United Kingdom: LÜTZE Ltd.

Unit 3, Sandy Hill Park

Sandy Way, Amington • GB-Tamworth, Staffs B77 4DU

Tel. +44 (0)1827 31333-0 • Fax +44 (0)1827 31333-2

www.lutze.com • sales.gb@lutze.co.uk



SYSTEMATIC TECHNOLOGY