



Identification	Type	RJ45-M 8pol. Cat.6A
	Part-No.	772102

Description	Industrial connector RJ45 IDC quick-connect technology, no tools required Category 6A
--------------------	---

Technical data	
Nominal voltage	50 V
Rated current	Max. 1.75 A per contact
Pol number	8
Transfer rate	10 Gbit/s
Transmission frequency	250 MHz, 10 GBit/s
Category	6A EIA/TIA 568B.2-10
Contact type	IDC
Shielding	yes

General	
Form	RJ45
Pollution degree	2
Insulation resistance	$\geq 100 \text{ M}\Omega$
Contact resistance	$\leq 50 \text{ m}\Omega$

29.01.2017 – Subject to technical modification

Part-No. 772102

USA: LUTZE INC.
13330 South Ridge Drive · Charlotte, NC 28273, USA
Tel. +1 (704) 504-0222 · Fax +1 (704) 504-0223
www.lutze.com · info@lutze.com

United Kingdom: LÜTZE Ltd.
Unit 3, Sandy Hill Park
Sandy Way, Amington · GB-Tamworth, Staffs B77 4DU
Tel. +44 (0)1827 31333-0 · Fax +44 (0)1827 31333-2
www.lutze.com · sales.gb@lutze.co.uk



Technical data sheet · Interface Technology

Class of flammability according to UL 94	V2
Protection class	IP 20
Housing material	PA black
Contact material	CuSn, gold-plated
Cable diameter	4.5 – 8 mm
Storage temperature range	-20 °C ... 70 °C
Operation temperature range	-20 °C – 70 °C
Dimensions (w × h × d)	56.0 × 13.3 × 17.2 mm
Mechanical service life	≥ 750 insertion cycles
Cross section	AWG 26-24
Weight (kg/piece)	0.012
PU	1

Dimensions

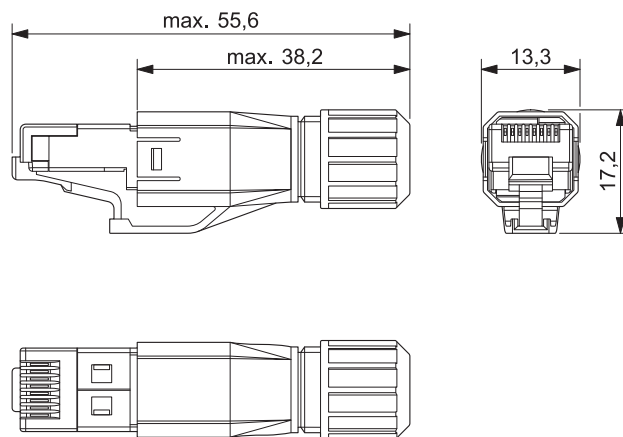

Connection assignment

RJ45

	TIA 568A	TIA 568 B	Profinet
1	WHGN	WHOG	YE
2	GN	OG	OG
3	WHOG	WHGN	WH
4	BU	BU	-
5	WHBU	WHBU	-
6	OG	GN	BU
7	WHBR	WHBR	-
8	BR	BR	-

29.01.2017 – Subject to technical modification

Part-No. 772102

USA: LUTZE INC.

13330 South Ridge Drive · Charlotte, NC 28273, USA
 Tel. +1 (704) 504-0222 · Fax +1 (704) 504-0223
 www.lutze.com · info@lutze.com

United Kingdom: LÜTZE Ltd.

Unit 3, Sandy Hill Park
 Sandy Way, Amington · GB-Tamworth, Staffs B77 4DU
 Tel. +44 (0)1827 31333-0 · Fax +44 (0)1827 31333-2
 www.lutze.com · sales.gb@lutze.co.uk



SYSTEMATIC TECHNOLOGY