

SW

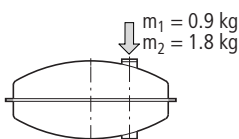

- (en) Rod operation
- (de) Stangenbetätigung
- (fr) Commande par tringle
- (es) Accionamiento por varilla
- (it) Azionamento ad asta
- (zh) 左支点
- (ru) Приведение в действие штанги

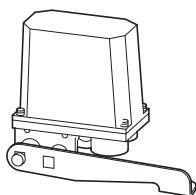
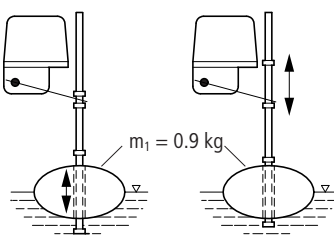

- (en) Cable operation
- (de) Seilbetätigung
- (fr) Commande par câble
- (es) Accionamiento por cable
- (it) Azionamento con fune
- (zh) 升程
- (ru) Приведение в действие каната

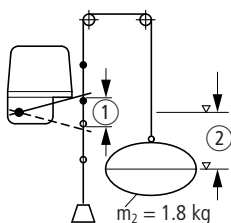

- ① (en) Travel
- (de) Hub
- (fr) Course
- (es) Carrera
- (it) Corsa
- (zh) 升程
- (ru) Ход

(en) **Electric current! Danger to life!**

Only skilled or instructed persons may carry out the following operations.

(de) **Lebensgefahr durch elektrischen Strom!**

Nur Elektrofachkräfte und elektrotechnisch unterwiesene Personen dürfen die im Folgenden beschriebenen Arbeiten ausführen.

(fr) **Tension électrique dangereuse !**

Seules les personnes qualifiées et averties doivent exécuter les travaux ci-après.

(es) **¡Corriente eléctrica! ¡Peligro de muerte!**

El trabajo a continuación descrito debe ser realizado por personas cualificadas y advertidas.

(it) **Tensione elettrica: Pericolo di morte!**

Solo persone abilitate e qualificate possono eseguire le operazioni di seguito riportate.

(zh) **触电危险!**

只允许专业人员和受过专业训练的人员进行下列工作。

(ru) **Электрический ток! Опасно для жизни!**

Только специалисты или проинструктированные лица могут выполнять следующие операции.



Z 2

- ② (en) Minimal adjustable differential
- (de) Niveaudifferenz
- (fr) Différence de niveau
- (es) Diferencia de nivel
- (it) Differenza di livello
- (zh) 左支点
- (ru) Разность уровней

- (en) Circuit examples
- (de) Schaltungsbeispiele
- (fr) Exemples de commande
- (es) Ejemplos de maniobra
- (it) Esempi di comando
- (zh) 升程
- (ru) Примеры включений

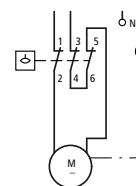
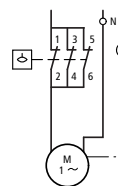
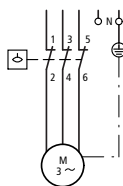
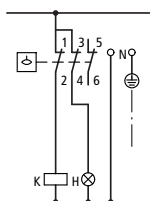

	2 x 0.75 - 2.5 mm ²	M ≤ 1.2 Nm (M ≤ 10.6 lb-in)
	2 x 0.5 - 1.5 mm ²	
	2 x 0.5 - 1.5 mm ²	

- ① (en) Fulcrum left
- (de) Drehpunkt links
- (fr) Axe de rotation à gauche
- (es) Punto de giro a la izquierda
- (it) Punto di rotazione a sinistra
- (zh) 左支点
- (ru) Точка вращения слева

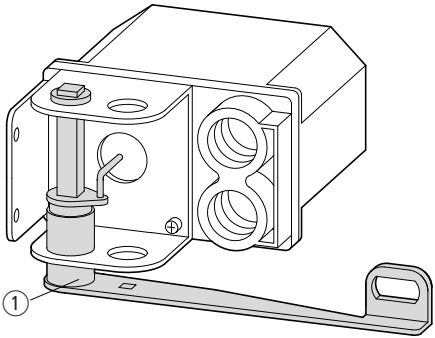
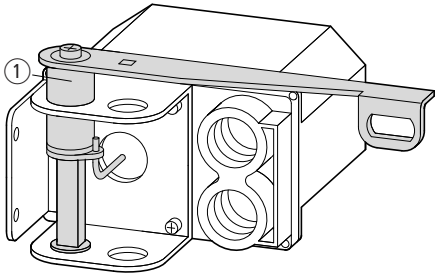

- ② (en) Fulcrum right
- (de) Drehpunkt rechts
- (fr) Axe de rotation à droite
- (es) Punto de giro a la derecha
- (it) Punto di rotazione a destra
- (zh) 空载
- (ru) Точка вращения справа

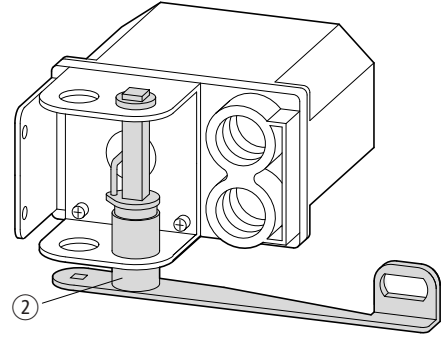
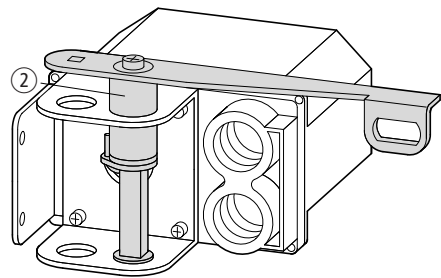

- (en) Filling
- (de) Vollpumpen
- (fr) Remplissage
- (es) Llenar
- (it) Riempimento
- (zh) 空载
- (ru) Заполнение

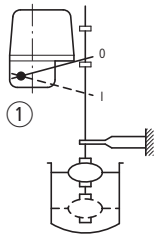
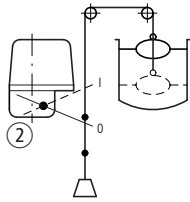

- (en) Emptying
- (de) Leerpumpen
- (fr) Vidange
- (es) Vaciar
- (it) Svuotamento
- (zh) 空载
- (ru) Оporож нени

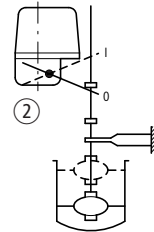
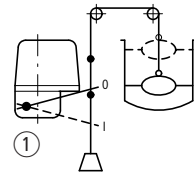

06/11 IL05212002Z