

## Signal Conditioners for Position Measurement

### MUK 350 Series



#### Special features

- interface module for position sensors
- aluminum die-cast housing; Protection class IP 66
- standardized output signals  
0...10 V  
±...10 V  
0...20 mA  
4...20 mA
- outstanding linearity
- extremely low temperature drift 30 ppm/K (typical value)
- zero point and range adjustable

The signal conditioner supplies position sensors with a highly stable constant voltage. The wiper signal is picked off without load via a high-resistance input stage and transformed into a displacement or rotationally proportional standardized output signal.

The excellent linearity, low temperature drift and sensor-proximity of the signal conditioning process ensure full utilization of the outstanding benefits of the connected position sensor

guaranteeing reliable, interference-free signal transmission even over long distances.

The zero point and range can be adjusted independently of each other within wide limits using spindle trimmers. This facility permits standardized output signals to be adjusted even if the maximum stroke or angle of the sensor is not completely utilized. The electronic circuitry is enclosed in an aluminum die-cast housing conforming to protection class IP 66. A UNI-sealed threaded joint ensures the correct EMC coupling of the cable shield. The wide operating voltage range allows the unit to be supplied with an unstabilized direct voltage source. Selected SMD components with a wide temperature range guarantee maximum operating reliability even under extreme environmental conditions.

The MUK 350 is connected by means of a four-pole terminal strip.

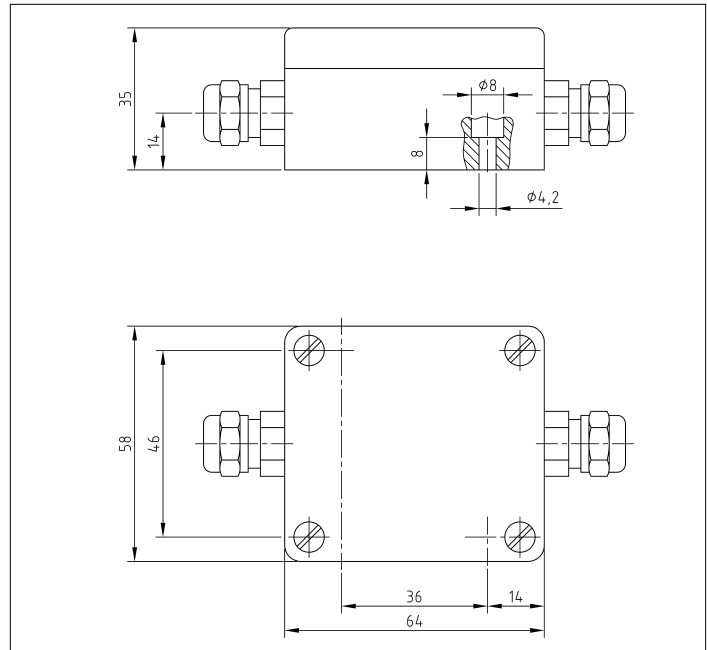

#### Mechanical Data

Dimensions	see drawing	
Protection class	IP 66 (DIN 400 50 / IEC 529)	
UNI-sealed threaded joint	PG 7	
Diameter of cable	4...6.5	mm
Screw-type terminals	1.0	mm <sup>2</sup>
Weight	app. 200	g

#### Electrical Data

Operating voltage	18...30	VDC
Input resistance	> 10	MΩ
Reverse voltage protection	integrated	
Max. current consumption	35	mA
Internal reference voltage for the position sensor, highly stable and short circuit-proof	10	VDC
Permissible connection-resistance of the position sensor	≥ 700	Ω
Adjustment range:		
Zero point	20	%
Gain	1...2	
Linearity	typical 0.01% FS	%
Temperature coefficient*	30	ppm/K
Temperature range*	-25...+70	°C

\*The TC applies for current and voltage outputs. If the voltage is picked off at the load resistor, the TC of the resistor must also be taken into account.

### Connecting diagram

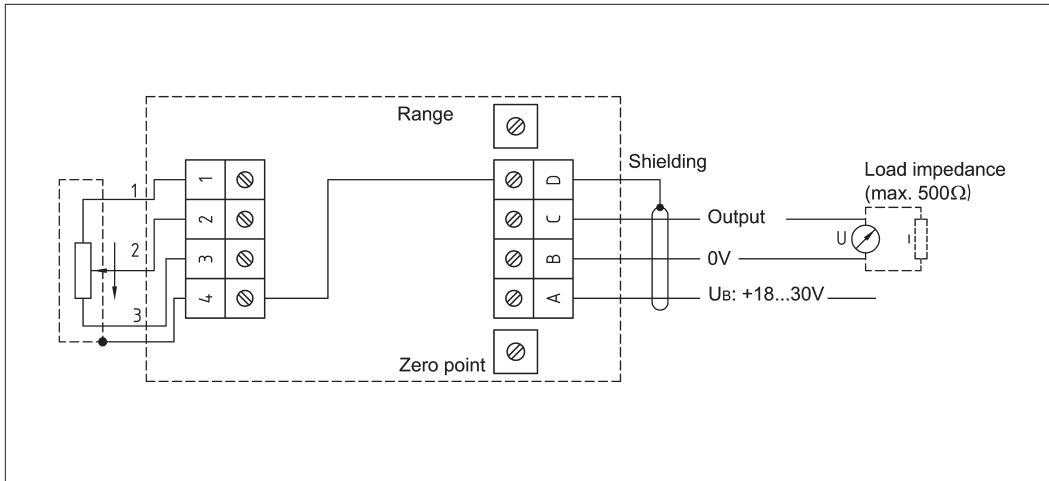

The output signal rises when the wiper is moved from position 1 to 3 (see connection diagram in the corresponding data sheet). For the reverse function, simply switch the connections 1 and 3 in the MUK housing.

### Order designation

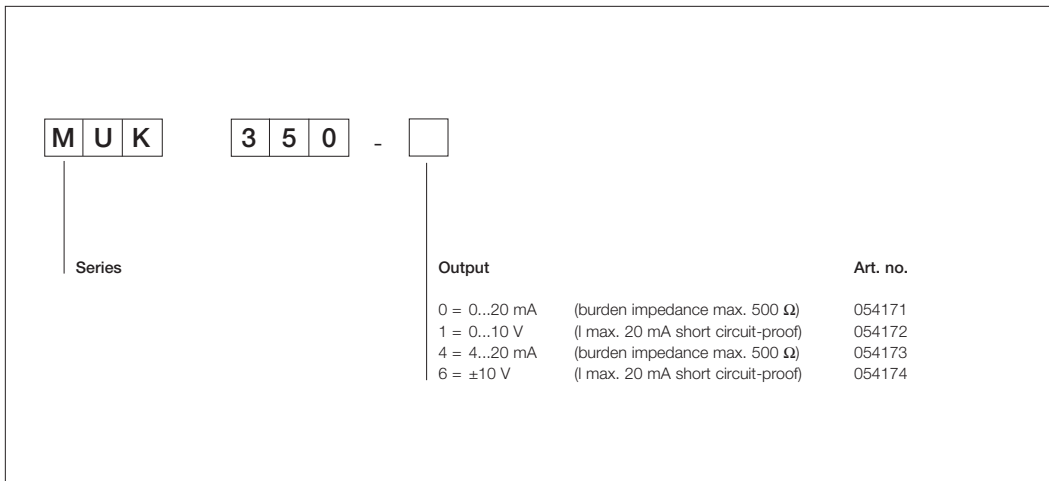

Other configurations available on request:

- with different output voltages
- with extended adjustment range
- with digital serial interface