



Bulletin 2533-M1/USA
Service Bulletin

Series R25P, R25S, R25V, R32P, R32S

Effective: July 1, 1995

Pilot Operated Relief Valves

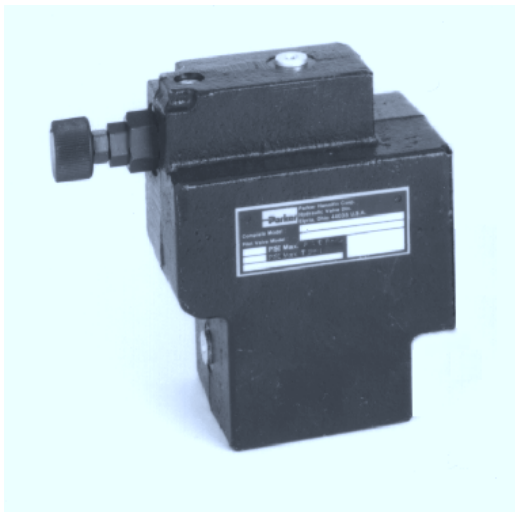

 **WARNING**

FAILURE OR IMPROPER SELECTION OR IMPROPER USE OF THE PRODUCTS AND/OR SYSTEMS DESCRIBED HEREIN OR RELATED ITEMS CAN CAUSE DEATH, PERSONAL INJURY AND PROPERTY DAMAGE.

This document and other information from Parker Hannifin Corporation, its subsidiaries and authorized distributors provide product and/or system options for further investigation by users having technical expertise. It is important that you analyze all aspects of your application and review the information concerning the product or system in the current product catalog. Due to the variety of operating conditions and applications for these products or systems, the user, through its own analysis and testing, is solely responsible for making the final selection of the products and systems and assuring that all performance, safety and warning requirements of the application are met.

The products described herein, including without limitation, product features, specifications, designs, availability and pricing, are subject to change by Parker Hannifin Corporation and its subsidiaries at any time without notice.

Offer of Sale

The items described in this document are hereby offered for sale by Parker Hannifin Corporation, its subsidiaries or its authorized distributors. This offer and its acceptance are governed by the provisions stated in the "Offer of Sale".

© Copyright 1995, Parker Hannifin Corporation, All Rights Reserved

Series R25P, R25S, R32P, R32S

Service Parts Information

Inline Mounted Relief Valve 1

Ordering Information

Inline Mounted Relief Valve 2

Series R25V

Service Parts Information

Subplate Mounted Relief Valve 3

Ordering Information

Subplate Mounted Relief Valve 4

Series R

Service Parts Information

Universal Pilot Cartridges

Knob Adjustment 5

Screw Adjustment 5

Key Lock 6

Operation 6

Trouble-Shooting 7

Inline Mounted

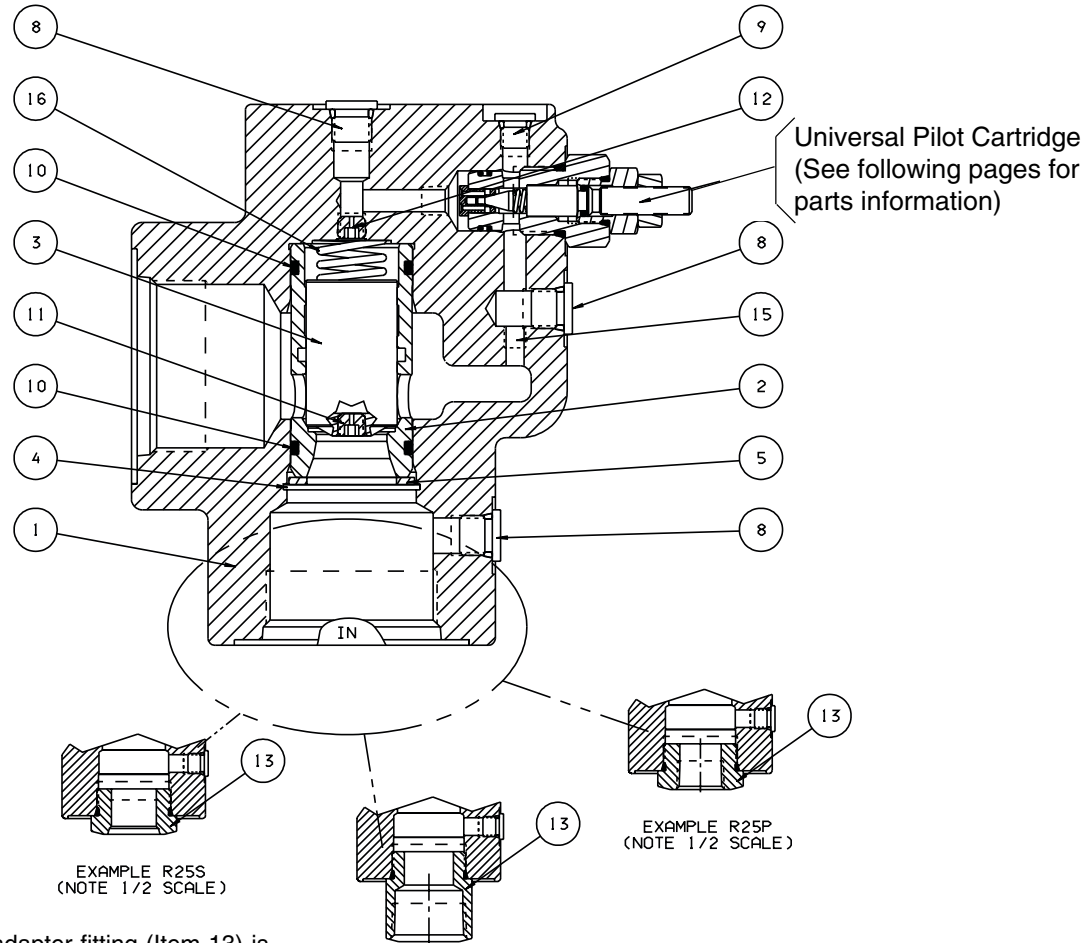

NOTE: Port adapter fitting (Item 13) is secured with Loctite 242. Heat may be required to remove port adapter. A new O-ring (3-920*-9) must be ordered.

ITEM	PART NO	DESCRIPTION	QTY
1	1301382	BODY	1
2	35036377	SLEEVE	1
3	45036379	POPPET	1
4	5004004	SNAP RING	1
5	5000665	WASHER	1
6	1301449	NAMEPLATE	1
7	39 X 10	DRIVE SCREW	2
8	4HP50*-S	HEX PLUG	3
9	2HP50*-S	HEX PLUG	1
10	2-122*-9	O-RING	2
11	45033519	Ø0.9 ORIFICE	1
12	45034721	Ø1.1 ORIFICE	1

TUBE FITTING TORQUE AND LOCTITE GUIDE			
ITEM	FITTING	TORQUE	LOC-TITE (242)
8	4HP50*-S	135±10 IN.LB. (15±1 N.M.)	NO
9	2HP50*-S	35±10 IN.LB. (3±.5 N.M.)	NO
11	45033519	108±10 IN.LB. (12±1 N.M.)	YES
12	45034721	108±10 IN.LB. (12±1 N.M.)	YES
13	20-12F50G5 *	225±12 FT.LB. (304±16 N.M.)	YES
13	20-1 1/4F50G *	225±12 FT.LB. (304±16 N.M.)	YES
13	20-3/4F50GS *	225±12 FT.LB. (304±16 N.M.)	YES

NAMEPLATE EXAMPLE

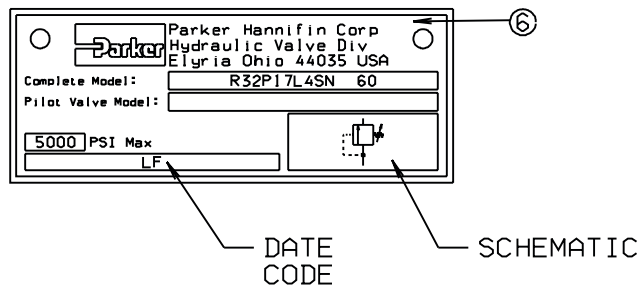

* refers to material.
 Use N for nitrile, V for Viton.

** Not shown.

Inline Mounted

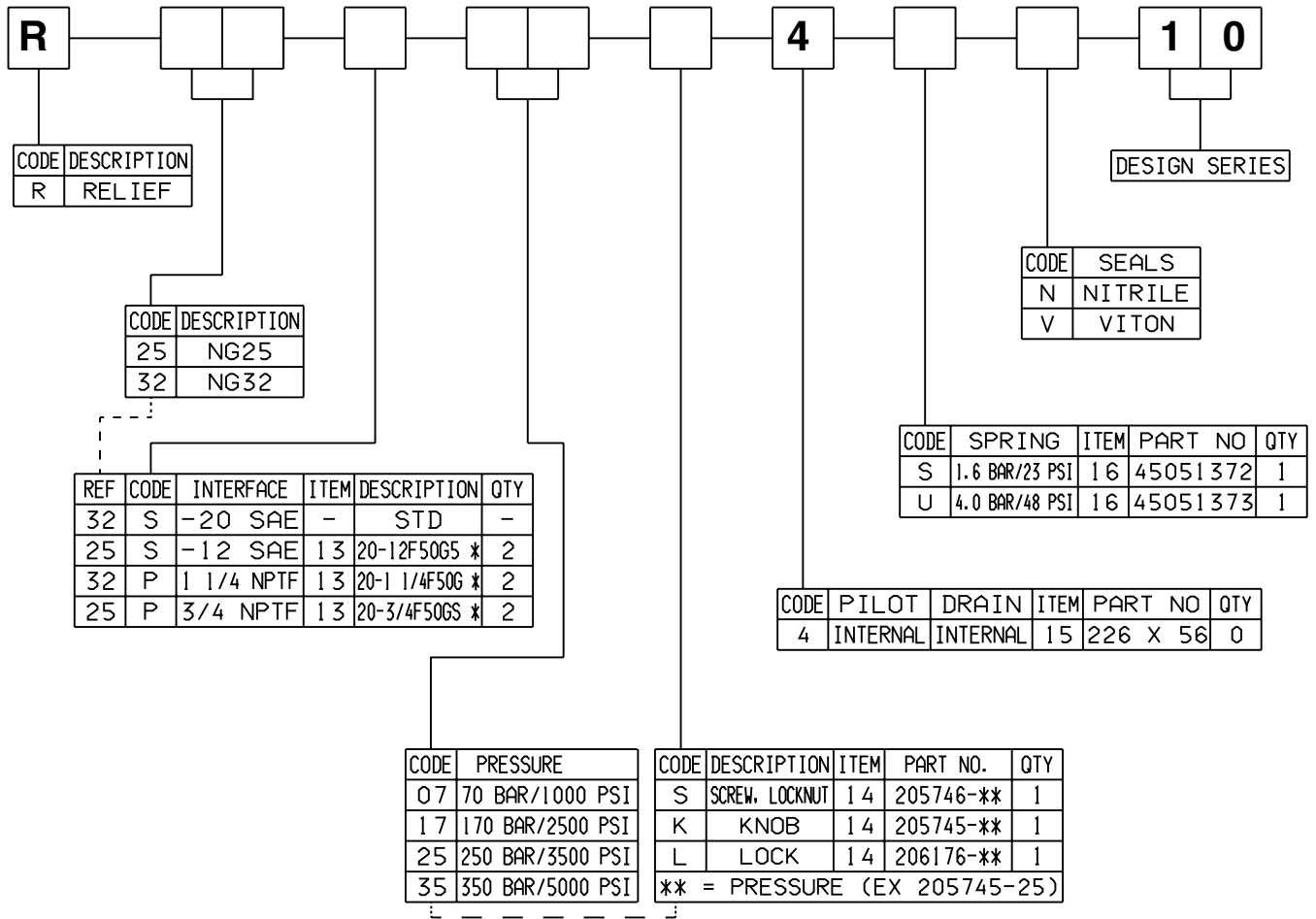

Subplate Mounted

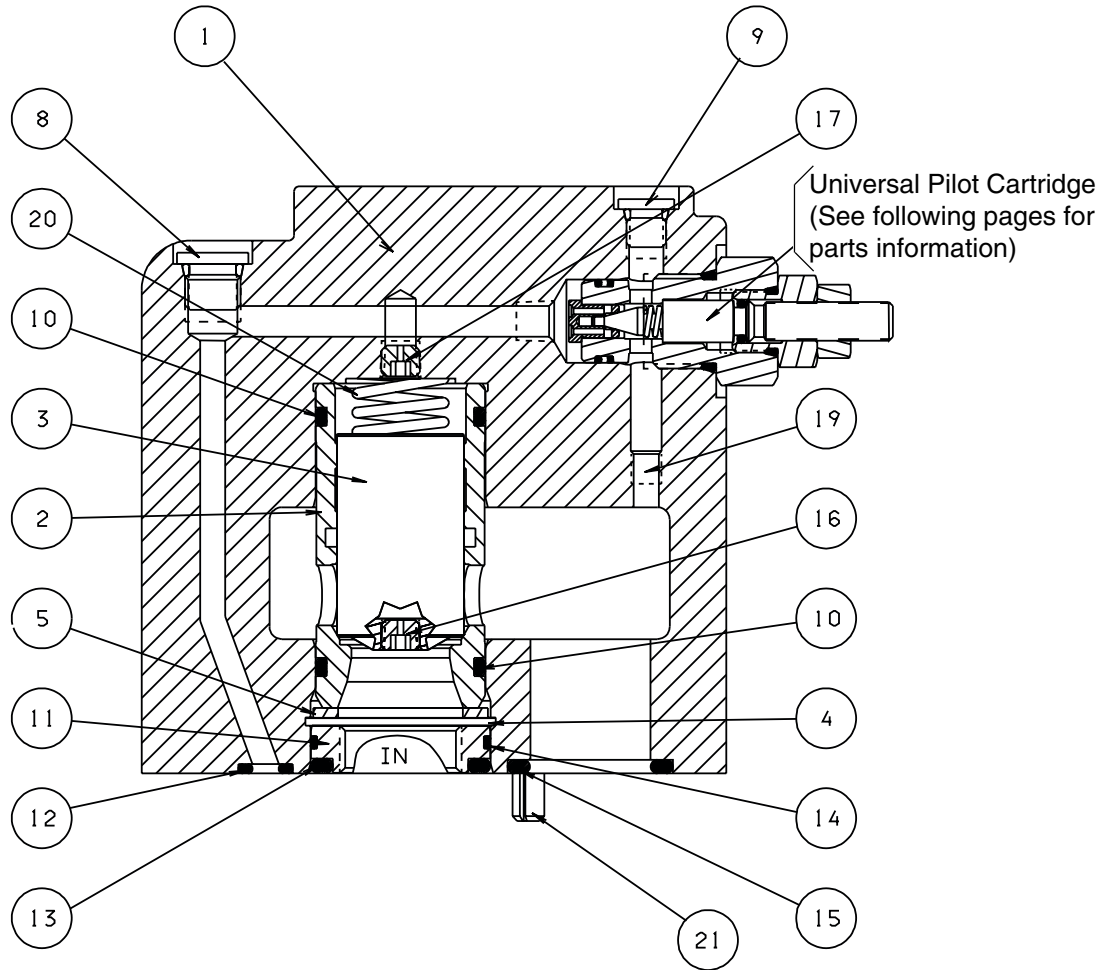

ITEM	PART NO	DESCRIPTION	QTY
1	1301478	BODY	1
2	35036377	SLEEVE	1
3	45036379	POPPET	1
4	5004004	SNAP RING	1
5	5000665	WASHER	1
6	1301449	NAMEPLATE	1
7	39 X 10	DRIVE SCREW	2
8	4HP50*-S	HEX PLUG	1
9	2HP50*-S	HEX PLUG	1
10	2-122*-9	O-RING	2
11	45037736	SPACER	1
12	2-012*-9	O-RING	1
13	2-217*-9	O-RING	1
14	2-027*-9	O-RING	1
15	2-215*-9	O-RING	1
16	45033519	Ø0.9 ORIFICE	1
17	45034721	Ø1.1 ORIFICE	1
21	99 X 125	ROLL PIN	1

TUBE FITTING TORQUE AND LOCTITE GUIDE			
ITEM	FITTING	TORQUE	LOC-TITE (242)
8	4HP50*-S	135±10 IN.LB. (15±1 N.M.)	NO
9	2HP50*-S	35±10 IN.LB. (3±.5 N.M.)	NO
16	45033519	108±10 IN.LB. (12±1 N.M.)	YES
17	45034721	108±10 IN.LB. (12±1 N.M.)	YES

NAMEPLATE EXAMPLE

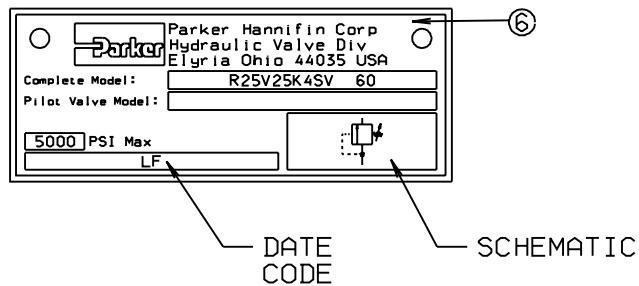

* refers to material.
Use N for nitrile, V for Viton.

** Not shown.

Subplate Mounted

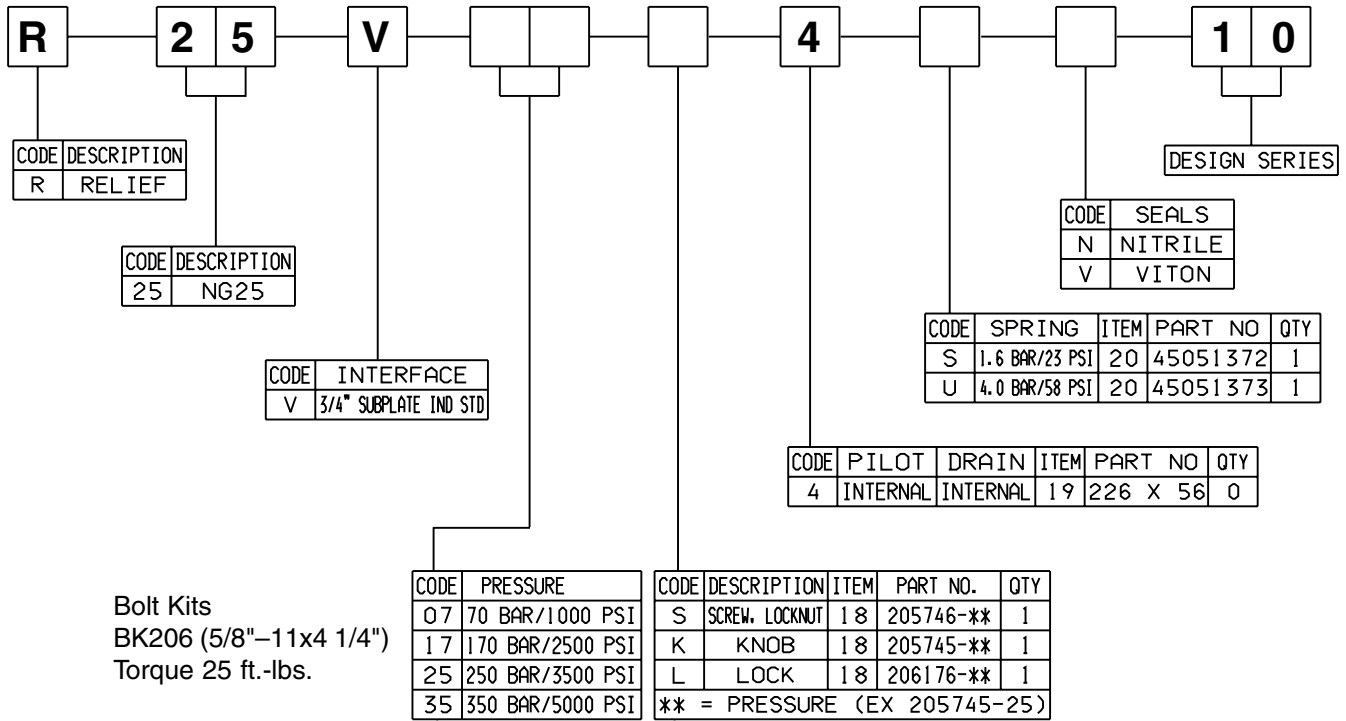

Bolt Kits
 BK206 (5/8"-11x4 1/4")
 Torque 25 ft.-lbs.

CODE	PRESSURE
07	70 BAR/1000 PSI
17	170 BAR/2500 PSI
25	250 BAR/3500 PSI
35	350 BAR/5000 PSI

CODE	DESCRIPTION	ITEM	PART NO.	QTY
S	SCREW, LOCKNUT	18	205746-**	1
K	KNOB	18	205745-**	1
L	LOCK	18	206176-**	1

** = PRESSURE (EX 205745-25)

Refer to following pages
 for additional information.

**Universal Pilot Cartridges
 Knob Adjustment**

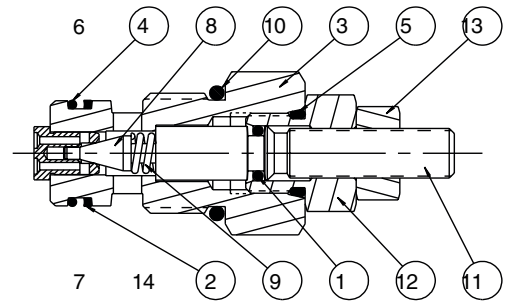
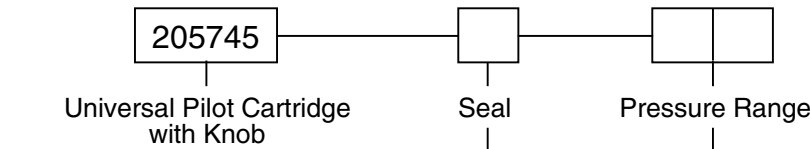

ITEM	PART NO.	DESCRIPTION	QTY.
1	700460	END PLUG	1
2	002193	PILOT HOUSING (S.A.)	1
3	058514	ADJUSTING SCREW	1
4	703007	DART	1
5	058540	HEX JAM NUT	1
6	2-014Δ-7	O-RING	1
7	8-014Δ-9	PARBAK RING	1
8	3-908Δ-9	O-RING	1
9	3-905Δ-9	O-RING	1
10	2-009Δ-9	O-RING	1
11	058538	KNOB	1
12	117 X 2	DOWEL PIN	1
13	058511	HANDLE NUT	1

CODE	MATERIAL
N	NITRILE
V	VITON

CODE	PRESSURE RANGE	ITEM	PART NO.	DESCRIPTION	QTY.
07	10-70 BAR (150-1000 PSI)	14	678884	SPRING	1
17	10-175 BAR (150-2500 PSI)	14	678885	SPRING	1
25	10-250 BAR (150-3500 PSI)	14	679935	SPRING	1
35	10-345 BAR (150-5000 PSI)	14	700465	SPRING	1

Δ refers to material.
 Use N for nitrile, V for Viton.

205745 can be made from 205746 (below) with the addition of Items 11, 12 and 13.

**Universal Pilot Cartridges
 Screw Adjustment**

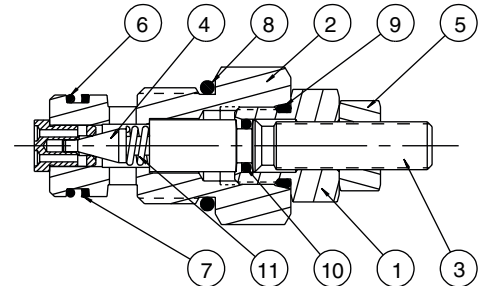
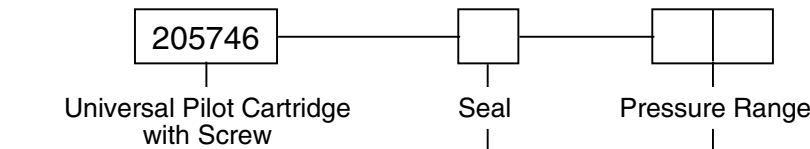

ITEM	PART NO.	DESCRIPTION	QTY.
1	700460	END PLUG	1
2	002193	PILOT HOUSING (S.A.)	1
3	058514	ADJUSTING SCREW	1
4	703007	DART	1
5	058540	HEX JAM NUT	1
6	2-014Δ-7	O-RING	1
7	8-014Δ-9	PARBAK RING	1
8	3-908Δ-9	O-RING	1
9	3-905Δ-9	O-RING	1
10	2-009Δ-9	O-RING	1

CODE	MATERIAL
N	NITRILE
V	VITON

CODE	PRESSURE RANGE	ITEM	PART NO.	DESCRIPTION	QTY.
07	10-70 BAR (150-1000 PSI)	11	678884	SPRING	1
17	10-175 BAR (150-2500 PSI)	11	678885	SPRING	1
25	10-250 BAR (150-3500 PSI)	11	679935	SPRING	1
35	10-345 BAR (150-5000 PSI)	11	700465	SPRING	1

Δ refers to material.
 Use N for nitrile, V for Viton.

**Universal Pilot Cartridges
Key Lock**

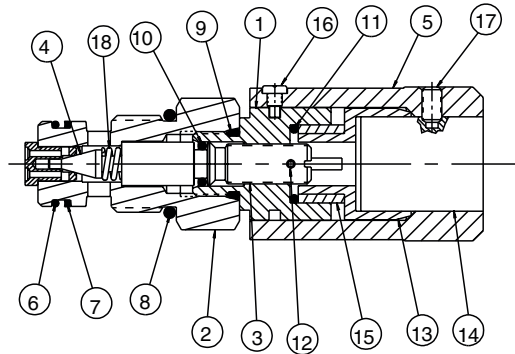
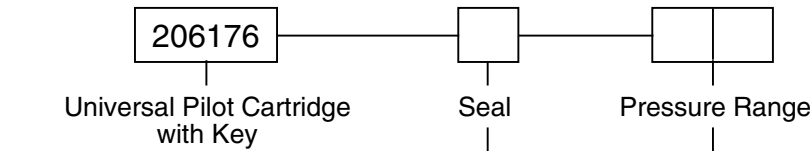

ITEM	PART NO.	DESCRIPTION	QTY.
1	700473	END PLUG	1
2	002193	PILOT HOUSING (S.A.)	1
3	700470	ADJUSTING SCREW	1
4	703007	DART	1
5	700469	SET COLLAR	1
6	2-014Δ-7	O-RING	1
7	8-014Δ-9	PARBAK RING	1
8	3-908Δ-9	O-RING	1
9	3-905Δ-9	O-RING	1
10	2-009Δ-9	O-RING	1
11	3-906N-7	O-RING	1
12	007186	DOWEL PIN	1
13	700472	COUPLING	1
14	007831	LOCK W/KEY	1
15	700471	SLEEVE	1
16	007832	SCREW	1
17	007833	SET SCREW	1

CODE	MATERIAL
N	NITRILE
V	VITON

CODE	PRESSURE RANGE	ITEM	PART NO.	DESCRIPTION	QTY.
07	10-70 BAR (150-1000 PSI)	18	678884	SPRING	1
17	10-175 BAR (150-2500 PSI)	18	678885	SPRING	1
25	10-250 BAR (150-3500 PSI)	18	679935	SPRING	1
35	10-345 BAR (150-5000 PSI)	18	700465	SPRING	1

206176 can be made from 205746 with the addition of Items 1, 3, and 12 through 17. Delete 058514 and 700460 from 205746.

Δ refers to material.
Use N for nitrile, V for Viton.

Operation

A pilot operated relief valve is a normally closed valve designed to open at a specific pressure determined by the pilot adjustment. The normal installation of the valve is to connect the inlet port to the point in the hydraulic circuit that is to be pressure limited. The outlet of the valve should be connected directly to the tank return line. The drain of the pilot is connected internally to the outlet of the valve and thus no external drain is required.

When the inlet pressure is less than the pilot setting the pilot dart is closed and the bias spring holds the

main poppet in the closed position. When the inlet pressure attempts to exceed the pilot setting, the pilot dart will open. A pressure drop will occur between the inlet pressure and the pressure on top of the main poppet due to the pilot flow through the control orifice in the poppet. The difference in pressures creates a force that overcomes the force of the bias spring and allows the poppet to open, relieving the inlet flow to the outlet (tank) and thus limiting the inlet pressure to the pilot setting.

Symptom	Cause	Solution
System won't build desired pressure	<i>Flow path is open down stream from Relief valve</i>	Check that pump is not being diverted via alternate flow path.
	<i>Pilot incorrectly adjusted</i>	Install pressure gage and readjust.
	<i>Pilot dart is held open</i>	Inspect for contamination.
	<i>Control orifices plugged</i>	Inspect for blockage of orifices (2).
	<i>Main poppet blocked open</i>	Check for free operation of main poppet — may be done through inlet port.
Excessive valve leakage	<i>Damaged main seat/poppet</i>	Inspect for score marks/ware — replace as required.
	<i>Pilot dart does not seat</i>	Inspect for score marks — replace as required.
	<i>Internal seal leakage</i>	Inspect insert cartridge pilot cartridge o-rings.
Excessive pressure	<i>Pilot incorrectly adjusted</i>	Install pressure gage and readjust.
	<i>Main poppet stuck</i>	Check for free operation through inlet port.
	<i>Inlet/outlet lines reversed</i>	Verify proper installation.
Excessive noise/ chatter	<i>Interaction with other pressure controls or remote pilots</i>	Readjust pressure of main control and/or remote control.
	<i>Worn seat or poppet</i>	Check main seat/poppet and pilot slot/dart. Replace if worn or damaged.



Parker Hannifin Corporation

Hydraulic Valve Division
520 Ternes Avenue
Elyria, Ohio 44035 USA
Tel: (216) 366-5200
Fax: (216) 366-5253



Printed on recycled paper,
using soy inks.

6/95, 4M, PHD, Printed in the USA