



Bulletin HY14-2533-M6/US
Service Bulletin

Series R6P*20**
R6V*20**

Effective: September 15, 2003
Supersedes: Bulletin PC0135-01



R Series
Two Stage Relief Valve

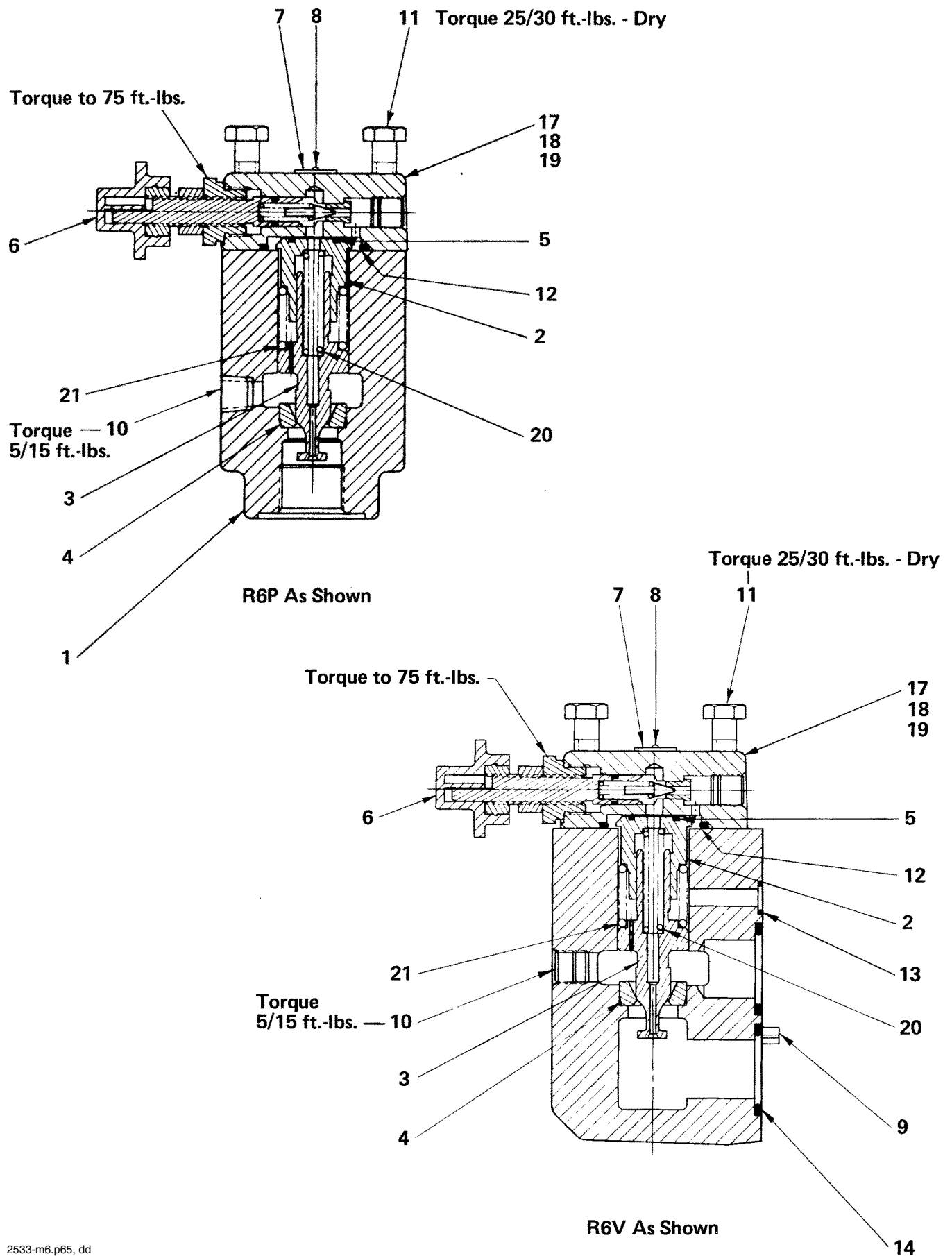

R
6
P(V)

20

PARTS LIST				
MODEL NO.	ITEM	QTY.	PART NUMBER	DESCRIPTION
R 6 P	1	1		
	2	1	693398	Balance SLU. — ¾ Rel.
	3	1	693401	Poppet
	4	1	693400	Seat
	5	1	693397	Seal Ring
	6	1	691299	Knob
	7	1	592101	Nameplate
	8	2	39 X 4	Drive Screw
	9	1	99 X 125	Roll Pin
	10	1	102 X 4	Pipe Plug
	11	4	116 X 48	Cap Screw
	12	1	2127 * - 7	O - Rings
	13	1	2012 * - 9	See Below
	14	2	2216 * - 9	For Compound
H	17	1	693454	Pilot Cap
F	18	1	693455	Pilot Cap
M	19	1	693455	Pilot Cap
OMIT	20	1	693396	L.V. Spring
8	21	1	693395	H.V. Spring
OMIT			* - N	Use Nitrile Seals
V			* - V	Use Viton Seals

Design Series

! WARNING

FAILURE OR IMPROPER SELECTION OR IMPROPER USE OF THE PRODUCTS AND/OR SYSTEMS DESCRIBED HEREIN OR RELATED ITEMS CAN CAUSE DEATH, PERSONAL INJURY AND PROPERTY DAMAGE.

This document and other information from Parker Hannifin Corporation, its subsidiaries and authorized distributors provide product and/or system options for further investigation by users having technical expertise. It is important that you analyze all aspects of your application and review the information concerning the product or system in the current product catalog. Due to the variety of operating conditions and applications for these products or systems, the user, through its own analysis and testing, is solely responsible for making the final selection of the products and systems and assuring that all performance, safety and warning requirements of the application are met.

The products described herein, including without limitation, product features, specifications, designs, availability and pricing, are subject to change by Parker Hannifin Corporation and its subsidiaries at any time without notice.

Offer of Sale

The items described in this document are hereby offered for sale by Parker Hannifin Corporation, its subsidiaries or its authorized distributors. This offer and its acceptance are governed by the provisions stated in the "Offer of Sale".

© Copyright 2003, 1980 Parker Hannifin Corporation, All Rights Reserved



Parker Hannifin Corporation
 Hydraulic Valve Division
 520 Ternes Avenue
 Elyria, Ohio, 44035 USA
 Tel: (440) 366-5200
 Fax: (440) 366-5253
 www.parker.com/hydraulicvalve

Bulletin HY14-2533-M6/US,
 9/03