

Wiring diagram

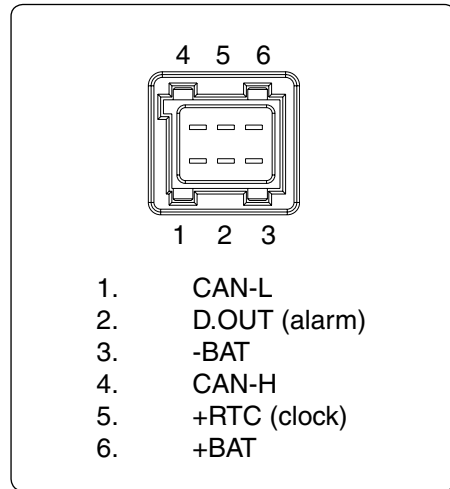

Mating connector kit: 5031022

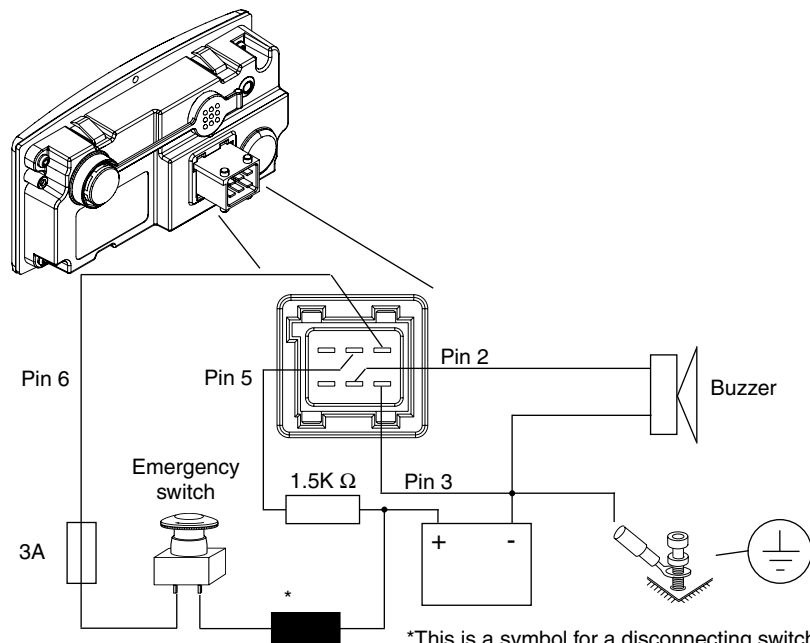
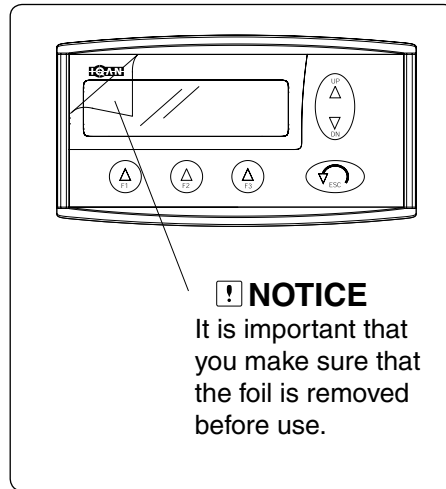

*This is a symbol for a disconnecting switch for battery, ignition lock and other fuses.

Installation

IQAN-MDM

Publ.no: M5010056A
Ed. A

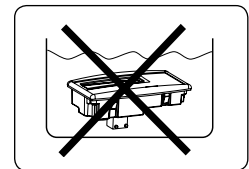
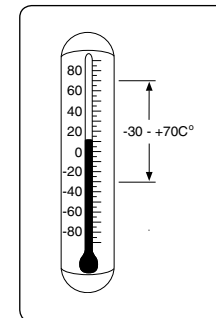
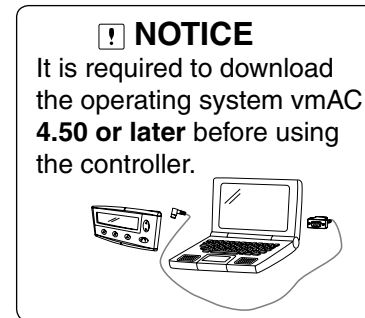
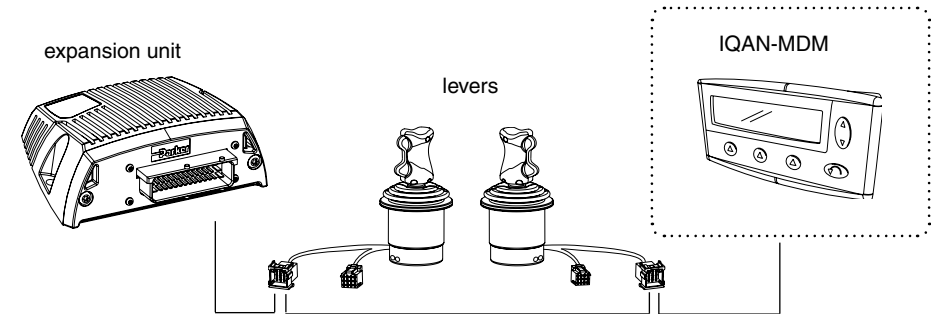

For further information see:
HY17-8328/UK Instructions, HY17-8363/UK Menu system

! WARNING

FAILURE OR IMPROPER SELECTION OR IMPROPER USE OF THE PRODUCTS AND/OR SYSTEMS DESCRIBED HEREIN OR RELATED ITEMS CAN CAUSE DEATH, PERSONAL INJURY AND PROPERTY DAMAGE.

This document and other information from Parker Hannifin Corporation, its subsidiaries and authorized distributors provide product and/or system options for further investigation by users having technical expertise. It is important that you analyze all aspects of your application, including consequences of any failure, and review the information concerning the product or system in the current product catalogue. Due to the variety of operating conditions and applications for these products or systems, the user, through its own analysis and testing, is solely responsible for making the final selection of the products and systems and assuring that all performance, safety and warning requirements of the application are met.

The products described herein, including without limitation, product features, specifications, designs, availability and pricing, are subject to change by Parker Hannifin Corporation and its subsidiaries at any time without notice.



IQAN-MDM

Installation alt. 1
unit = mm

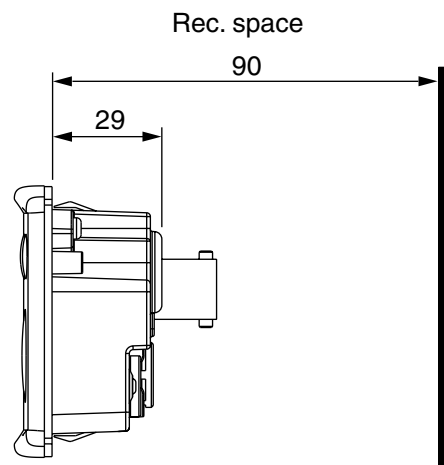
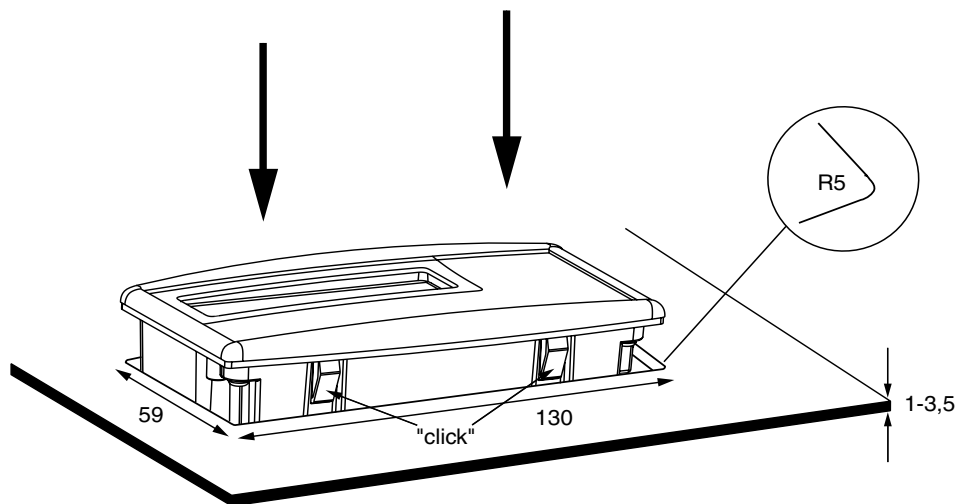

IQAN-MDM

Installation alt. 2
unit = mm

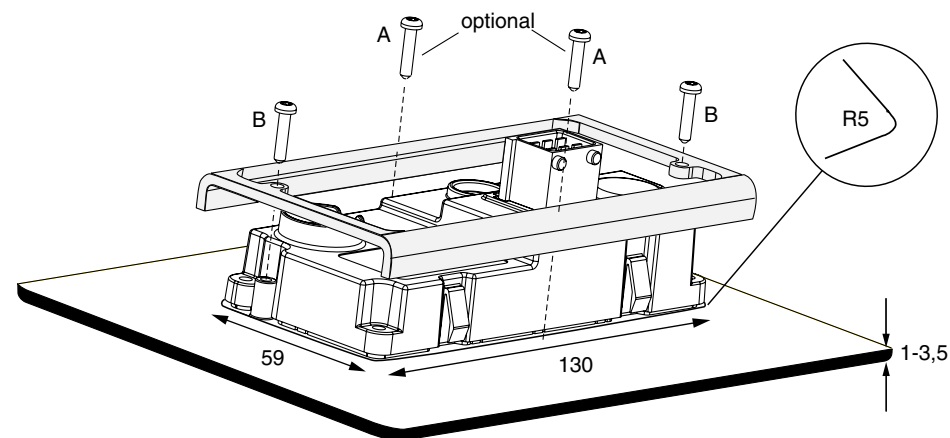

! NOTICE

Use only recommended type of screw.

- PT3 (or PT30 or K30) is the designation for 3 mm dia. screw.
- Screw type must be; high helix, self-threading screw for thermoplastics.

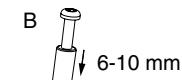

! NOTICE

Screw engagement must be 4-6 mm for screw position A.

- Less engagement and the screw may not hold.
- More engagement and the housing may be damaged.

! NOTICE

Screw engagement must be 6-10 mm for screw position B.

- Less engagement and the screw may not hold.
- More engagement and the housing may be damaged.