



**Model Number**

**GL-ES-IR-5800/115/120**

Photoelectric slot sensor

**Features**

- Infrared light source
- Not sensitive to ambient light
- High switching frequency
- Robust and insensitive to ambient interference
- Tolerant to supply voltage variations up to 60 V DC

**Dimensions**

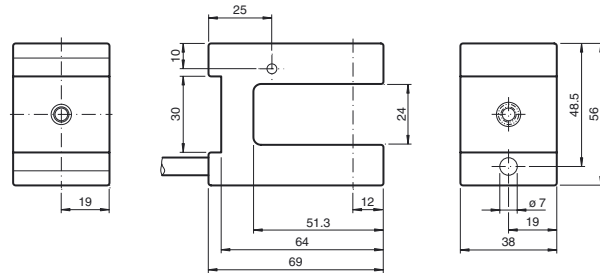

**Electrical connection**

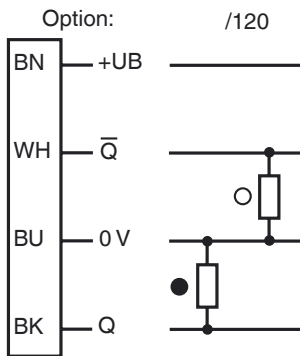

○ = Light on  
● = Dark on

**Indicators/operating means**

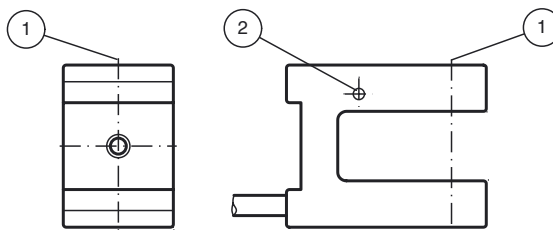

1	Optical axis	
2	Signal display	red

Release date: 2012-11-14 16:13 Date of issue: 2012-11-14 253073\_eng.xml

**Technical data****General specifications**

Sensing range	0 ... 24 mm
Light source	LED
Light type	infrared , 950 nm
Tests	EN 60947-5-2
Marking	CE
Fork width	24 mm
Ambient light limit	halogen light 100000 Lux ; according to EN 60947-5-2:2007

**Indicators/operating means**

Operating display	LED red
-------------------	---------

**Electrical specifications**

Operating voltage	$U_B$	10 ... 30 V DC
Ripple		10 %
No-load supply current	$I_0$	≤ 25 mA
Time delay before availability	$t_v$	≤ 10 ms

**Output**

Switching type	light/dark on	
Signal output	2 PNP complementary , Reverse polarity protection , open collectors	
Switching voltage	max. 30 V DC	
Switching current	max. 100 mA	
Voltage drop	$U_d$	≤ 2 V
Switching frequency	$f$	100 Hz
Response time		5 ms

**Ambient conditions**

Ambient temperature	-25 ... 55 °C (-13 ... 131 °F)
Storage temperature	-30 ... 70 °C (-22 ... 158 °F)

**Mechanical specifications**

Protection degree	IP67
Connection	3.5 m fixed cable

**Material**

Housing	PPO
Optical face	PC

**Compliance with standards and directives**

Standard conformity	
Product standard	EN 60947-5-2:2007 IEC 60947-5-2:2007