

SIEMENS

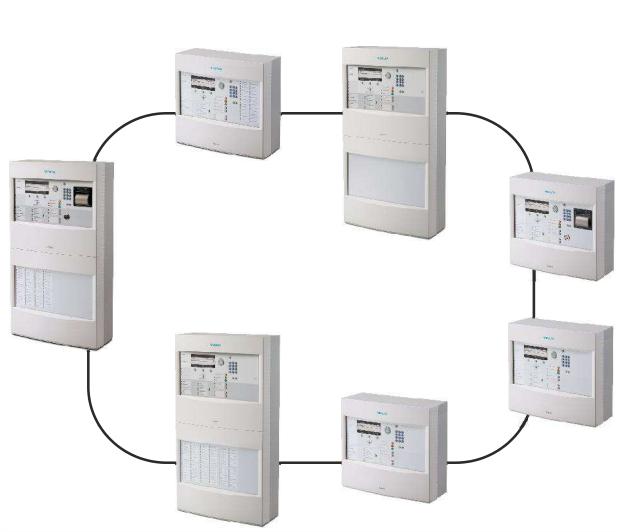

FS20/FS720

Fire detection system

External printer

Application Guide

Legal notice

Technical specifications and availability subject to change without notice.

© 2012 Copyright by Siemens Switzerland Ltd

Transmittal, reproduction, dissemination and/or editing of this document as well as utilization of its contents and communication thereof to others without express authorization are prohibited. Offenders will be held liable for payment of damages. All rights created by patent grant or registration of a utility model or design patent are reserved.

Issued by:

Siemens Switzerland Ltd.

Infrastructure & Cities Sector

Building Technologies Division

International Headquarters

Gubelstrasse 22

CH-6301 Zug

Tel. +41 41 724-2424

www.siemens.com/buildingtechnologies

Edition: 03.04.2012

Document ID: A6V10224853_c_en_--

Table of contents

1	About this document	5
1.1	Applicable documents.....	6
1.2	History of changes.....	7
2	System requirements	8
3	Overview	9
4	Connection to RS232 interface	10
5	Connection to Ethernet via print server PS01a	11
6	Information about commissioning	13
7	Configuration with SintesoWorks/Cerberus Engineering Tool	14
8	Configuring print server	15
9	Commissioning external printer	16
10	List of items	22

1 About this document

Goal and purpose

This document contains information relating to application and should be given to the technical personnel to assist them in connecting an external printer in the FS20/FS720 fire detection system. Use of a printer recommended by Siemens is described in the document by way of example.

Scope

The information contained in this document is valid for the FS20/FS720 fire detection systems.

Target groups

The information in this document is intended for the following target groups:

Target group	Activity	Qualification
Commissioning personnel	<ul style="list-style-type: none"> ● Configure the product at the place of installation according to customer-specific requirements. ● Check the product operability and release the product for use by the operator. ● Searches for and corrects malfunctions. 	<ul style="list-style-type: none"> ● Has obtained suitable specialist training for the function and for the products. ● Has attended the training courses for commissioning personnel.
Installation personnel	<ul style="list-style-type: none"> ● Assembles and installs the product components at the place of installation. ● Carries out a performance check following installation. 	<ul style="list-style-type: none"> ● Has received specialist training in the area of building installation technology or electrical installations.

Reference document and source language

- The source language of this document is German (de).
- The reference version of this document is the international version in English. The international version is not localized.

The reference document has the following designation:

ID_x_en_--

x = modification index, en = English, -- = international

Document identification

The document ID is structured as follows:

ID code	Examples
ID_ModificationIndex_Language_COUNTRY -- = multilingual or international	A6V10215123_a_de_DE A6V10215123_a_en_-- A6V10315123_a_--_--

Conventions for text marking

Markups

Special markups are shown in this document as follows:

▷	Requirement for a behavior instruction
⇒	Intermediate result of a behavior instruction
⇨	End result of a behavior instruction
[→ X]	Reference to a page number
'Text'	Quotation, reproduced identically
<Key>	Identification of keys

Supplementary information and tips



The 'i' symbol identifies supplementary information and tips for an easier way of working.

1.1 Applicable documents

Document ID	Title
008851	FS20 Fire Detection System, Installation
009078	FS20 Fire Detection System, Configuration
009052	FS20 Fire Detection System Commissioning, Maintenance, Troubleshooting
A6V10210390	FS720 Fire Detection System, Installation
A6V10210416	FS720 Fire Detection System, Commissioning, Maintenance, Troubleshooting
A6V10210424	FS720 Fire Detection System, Configuration
Product insert, CD from Fujitsu	Printer DL3750+
www.seh.de	Print server PS01a
www.seh.de/support_forum/viewtopic.php?t=104	Configuration of print server PS01a

1.2 History of changes

The reference document's modification index applies to all languages into which the reference document is translated.



The first edition of a language version or a country variant may for example have the modification index 'd' instead of 'a' if the reference document already has this modification index.

The table below shows this document's history of changes:

Modification index	Edition date	Brief description
c	04.2012	Formal changes
b	06.2010	Formal changes
a	11.2008	First edition

2 System requirements

An external printer in the FS20/FS720 fire detection system must satisfy the following requirements:

- Compatible with IBM ProPrint format
- Compatible with the ISO character sets required in the country in question and supported by the system, for example with the following:
 - 8859-1
 - 8859-2
 - 8859-5
 - 8859-9
 - 8859-15

Recommended printers

The Fujitsu DL3750+ printer is approved as a monitored, external printer in the FS20/FS720 fire detection system.

By monitoring the printer, printer faults or faults in the connection between the printer and fire detection system are indicated as system messages.

Possible connections

- Directly via RS232 to module FCA2001-A1
- Indirectly via Ethernet with print server PS01a



Other printer types can also be connected to the FS20/FS720 fire detection system if they support the IBM ProPrint format and the corresponding character sets.

Unlike the Fujitsu DL3750+, these printers are not however approved and do not support printer monitoring by the connected station.

3 Overview

One external printer can be connected per station in the FS20/FS720 fire detection system.

Visibility

The 'visibility' of the printer can be configured individually in SintesoWorks/Cerberus Engineering Tool, according to the 'visibility concept'.

4 Connection to RS232 interface

The RS232 module, type FCA2001-A1, is used for connection to the station.

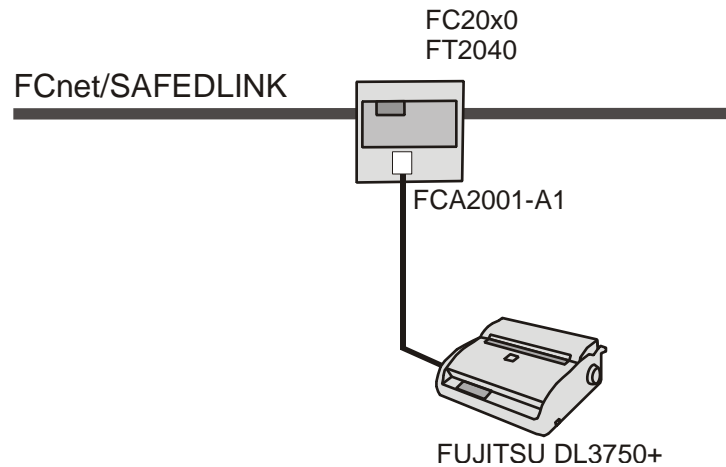

External printer with connection RS232, type FCA2001-A1

Preconditions for connection

- The station has an RS232 module (isolated) FCA2001-A1.
- An external printer is created in SintesoWorks/Cerberus Engineering Tool for this station.
- The connection cable is wired following the connection diagram. The shielding to the connector housing and FS20/FS720 housing offers EMC protection (C).
- The connection cable with 25-pole connector (B, see below) is connected to the printer.
- The connection cable is a maximum of 15 meters in length.

Connection diagram for printer cable

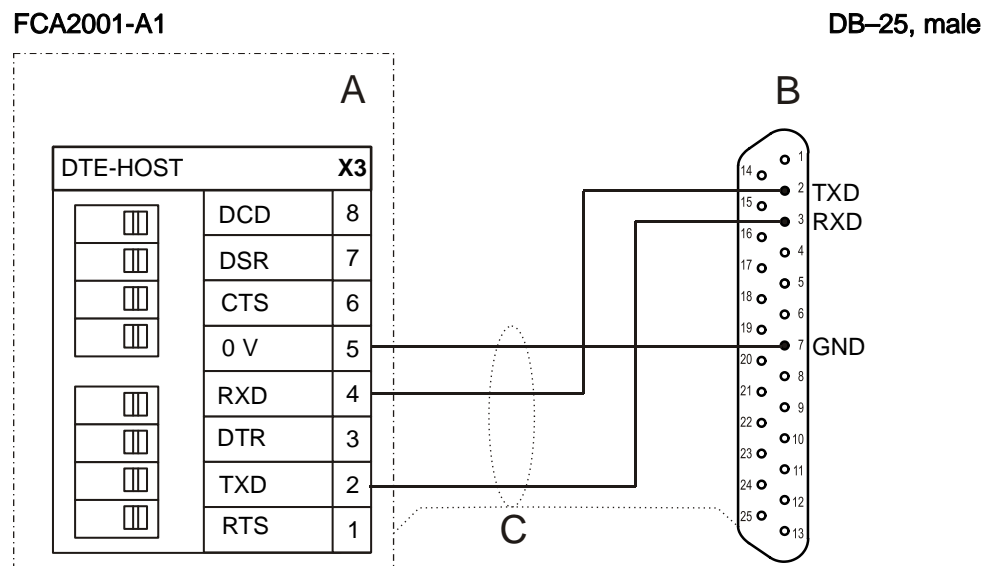

A = Screw connection on RS232 module (isolated) FCA2001-A1

B = 25-pole connector (DB-25, male) for Fujitsu DL3750+ printer

C = Cable shielded with shield connection to housing and connector housing in version stated in list of items

5 Connection to Ethernet via print server PS01a

A print server is used for the connection to the Ethernet.

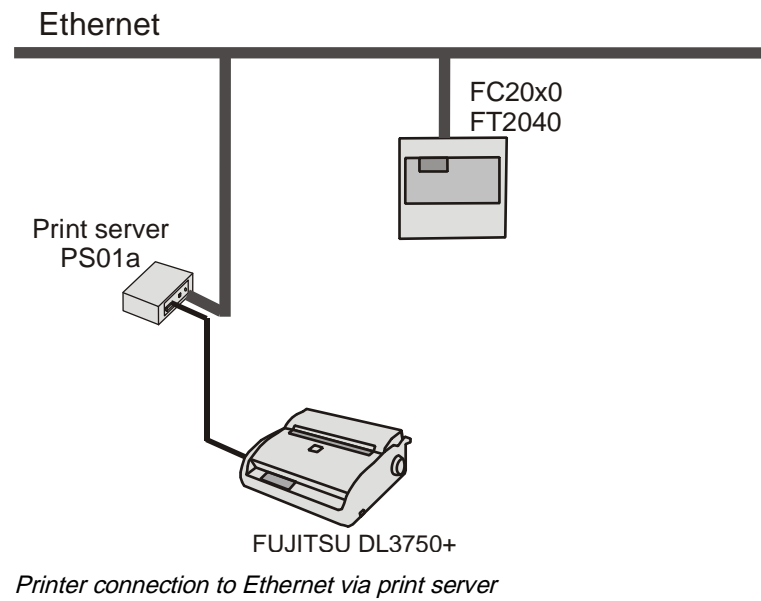

Preconditions for connection

- An external printer is created in SintesoWorks/Cerberus Engineering Tool for one station.
- The print server PS01a is configured with the settings needed for the network.
- Print server PS01a is connected to the power supply and Ethernet.
- The connection cable has a 9-pole socket and 25-pole connector.
- The connection cable is a maximum of 15 meters in length.
- The connection cable is wired following the connection diagram. The shielding to the connector housings offers EMC protection (C).

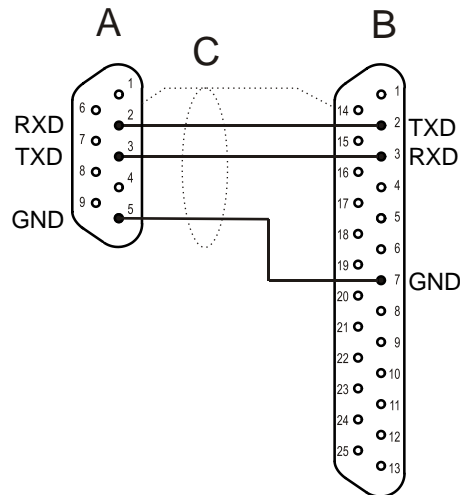

Connection diagram for cable from print server to printer

A = 9-pole socket (DE-9, female) for print server PS01a

B = 25-pole connector (DB-25, male) for Fujitsu DL3750+ printer

C = Cable shielded with shield connection to connector housings in version stated in list of items

See also

[Configuring print server \[→ 15\]](#)

[Configuration with SintesoWorks/Cerberus Engineering Tool \[→ 14\]](#)

6 Information about commissioning

An external printer is commissioned in three or four stages:

- Satisfy hardware conditions for the corresponding connection
- Configuration of an external printer in the FS20/FS720 fire detection system with SintesoWorks/Cerberus Engineering Tool
- Configure print server if the printer is connected to the Ethernet
- Commissioning external printer



Note the product documentation provided in the scope of supply.

Information about FS20/FS720

- 'Configuration' document, see 'Event printer'
- 'Commissioning, maintenance, troubleshooting' document, see 'Commissioning external printer'

Information about Fujitsu DL3750+ printer

- Documentation on CD within scope of supply
- 'Commissioning external printer' chapter in this document

Information about print server PS01a (only if connected via Ethernet)

- 'Configuring print server' in this document
- Documentation from SEH
 - CD-ROM in scope of supply
 - www.seh.de
- Configuration with InterCon-NetTool program
 - Assignment of an IP address:
http://www.seh.de/support_forum/viewtopic.php?t=104.
 - Reset print server PS01a:
http://www.seh.de/support_forum/viewtopic.php?t=103
http://www.seh.de/support_forum/viewtopic.php?t=104.

See also

- [Configuring print server \[→ 15\]](#)
- [Commissioning external printer \[→ 16\]](#)
- [Configuration with SintesoWorks/Cerberus Engineering Tool \[→ 14\]](#)

7 Configuration with SintesoWorks/Cerberus Engineering Tool

The 'external printer' element is created in SintesoWorks/Cerberus Engineering Tool.



The document 'Configuration' in the FS20/FS720 documentation includes how to create an 'external printer' element in the FS20/FS720 fire detection system.

1. Create an 'external printer' element in the 'Operation' register.
2. Define the 'visibility' for the printer.
3. Link the printer to the intended connection
 - 'RS232 interface'
or
 - 'Ethernet printer'

8 Configuring print server

The print server's IP address must be in the corresponding address range of the Ethernet (system) and is defined on the print server.



The print server must be configured before connecting to the Ethernet (system).

Settings on the print server

- Subnet screen 255.255.255.0 (basic setting)
- IP address for print server PS01a in the range between 192.168.200.6 and 192.168.200.254

Entering IP address

- ▷ The print server is not linked to the Ethernet (system).
 - ▷ The print server is linked to a PC.
 - ▷ Administration using an Internet browser or InterCon NetTool is possible.
1. Set the IP address for the PS01a print server.
See http://www.seh.de/support_forum/viewtopic.php?t=104.
 2. Check that the IP address is issued correctly.
 - ⇒ The print server is ready for connection to the Ethernet (system).
 - ⇒ The printer can be connected to the Ethernet (system) via the print server.

9 Commissioning external printer

The external printer FUJITSU DL3750+ can be installed and commissioned following the operation manual. The operation manual can be found on the CD supplied with the printer.

Printing status report

Print out the 'Setup Parameters' status report and compare it with the settings required. Create the report as follows:

- ▷ The printer must contain continuous paper.
 - ▷ The paper selection lever must be set to continuous.
1. Press <ONLINE>.
 - ⇒ The 'ONLINE' LED goes out and the printer is OFFLINE.
 2. Press <TEAR OFF> and <ONLINE> at the same time.
 - ⇒ The 'OFFLINE SETUP MODE' report is printed.

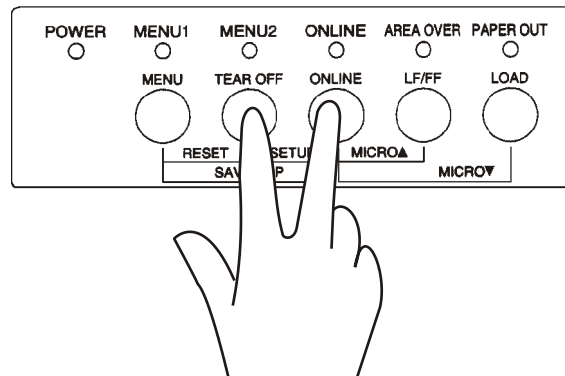

Printer keys

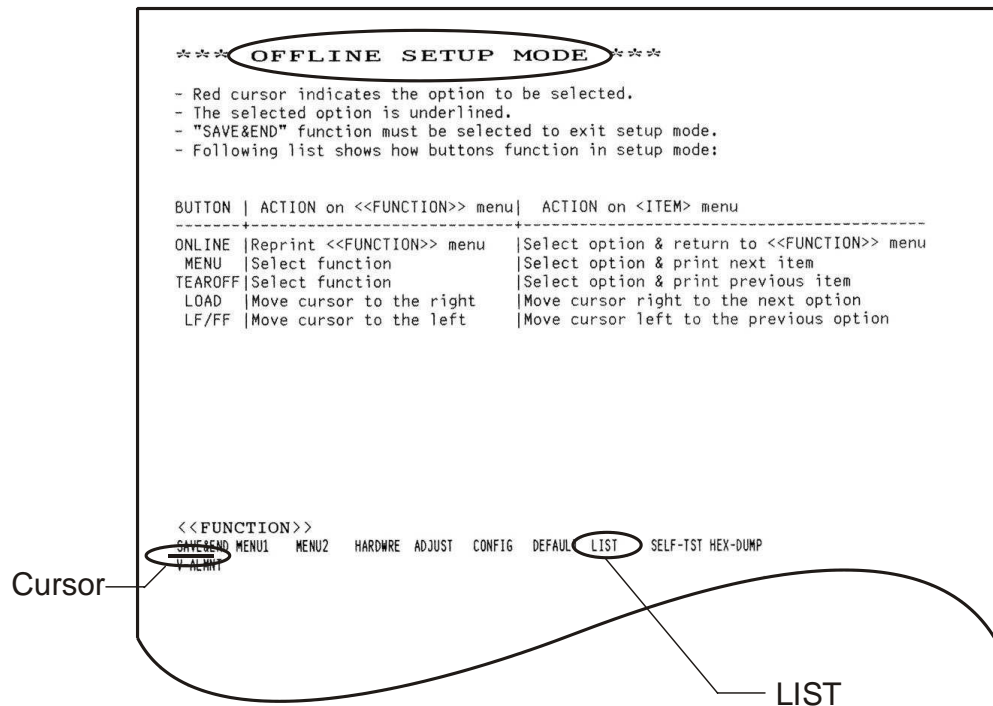

Print-out of OFFLINE SETUP MODE

3. Use the <LF/FF> or <LOAD> keys under the text 'LIST' to move the cursor.
 4. To select, press <MENU>.
- ⇒ The 'SETUP Parameters' status report is printed.

Switching ONLINE

1. Use <LF/FF> or <LOAD> keys under the text 'SAVE & END' to move the cursor.
 2. Press <MENU>.
- ⇒ The 'ONLINE' LED lights up.

Checking status report

The status report contains the printer settings for **Menu 1**, **Menu 2**, **Hardware**, **Adjust**, and **Config**.



If not all the functions listed in the following table are to be printed in the status report, the functions can be printed individually as explained in the 'Changing status settings' section below.

- Compare the status report with the settings required from the following table.

	Function	Value
MENU 1		
	EMULATE	XL24E
	FONT	COUR 10
	QUALITY	LETTER
	PITCH	10 CPI
	LINE SP	6 LPI
	CHAR-W	NORMAL
	CHAR-H	NORMAL
	ATTRIB	NONE
	PAGE LG	12.0 IN
	LFT-END	1 COLM
	TOP-MRG	1 LINE
	LANGUAGE	LATIN-9
	CHR-SET	SET1
	AGM	OFF
	PRF-SKP	NO-SKIP
	ZEROFNT	NO-SLSH
	CR-CODE	CR ONLY
	LF-CODE	LF & CR
	RGHTEND	WRAP
	==END==	

	Function	Value
MENU 2		
	EMULATE	DPL24C+
	FONT	COUR 10
	QUALITY	LETTER
	PITCH	10 CPI
	LINE SP	6 LPI
	CHAR-W	NORMAL
	CHAR-H	NORMAL
	ATTRIB	NONE
	PAGE LG	11.0 IN
	LFT-END	1 COLM
	TOP-MRG	1 LINE
	LANGUAGE	PAGE437
	CHR-SET	SET2
	PRF-SKP	NO-SKIP
	ZEROFNT	NO-SLSH
	DC3-CDE	ENABLE
	CR-CODE	CR ONLY
	LF-CODE	LF & CR
	RGHTEND	WRAP
	==END==	
HARDWRE		
	PPR-OUT	DETECT
	PRT-DIR	BI-DIR
	BUZZER	ON
	WORD-LG	8 BIT
	BUFFER	NONE
	INTRFCE	SERIAL
	FORMAT	8NONE 1
	BAUD-RT	9600
	PROTOCL	XON/XOF
	DSR	IGNORE
	DUPLEX	FULL
	CTS	IGNORE
	CD	IGNORE
	==END==	

	Function	Value
ADJUST		
	CNT-ORG	1 /6 IN
	CNTFINE	1 /180
	CUT-ORG	1 /6 IN
	CUTFINE	1 /180
	CNT-LFT	0 /90
	CUT-LFT	0 /90
	CUT-ADJ	0 /360
	CNT-ADJ	0 /360
	CNTADJL	0 /360
	==END==	
CONFIG		
	TEAROFF	AUTO
	TEARPOS	VISIBLE
	TEAR-EN	4 SEC
	CUTLOAD	BUTTON
	DECODE	DIRECT
	AREACNT	DISABLE
	ON-LOAD	ONLINE
	LOCK	NONE
	// S //	DISABLE
	CONT-PE	EDGE
	GATHER	DISABLE
	CUT-CTL	SPEED
	SKIP-PR	ENABLE
	STATUS	ENABLE
	BANDCTL	ENABLE
	TOF-CTL	DRIVER
	==END==	

Settings required

Changing status settings

Change the settings as follows:

1. Press <ONLINE>.
 - ⇒ The 'ONLINE' LED goes out and the printer is OFFLINE.
2. Press <TEAR OFF> and <ONLINE> at the same time.
 - ⇒ The 'OFFLINE SETUP MODE' report is printed.

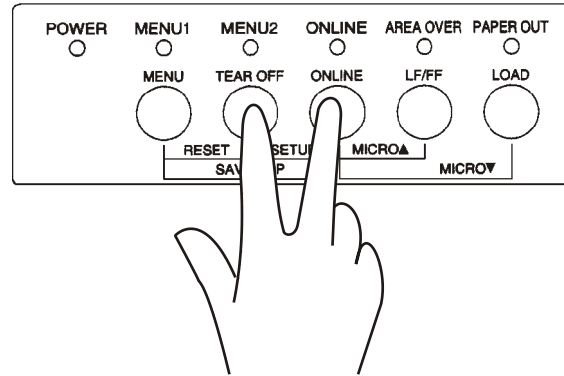

Printer keys

```

*** OFFLINE SETUP MODE ***
- Red cursor indicates the option to be selected.
- The selected option is underlined.
- "SAVE&END" function must be selected to exit setup mode.
- Following list shows how buttons function in setup mode:

BUTTON | ACTION on <<FUNCTION>> menu | ACTION on <ITEM> menu
-----+-----+-----
ONLINE | Reprint <<FUNCTION>> menu | Select option & return to <<FUNCTION>> menu
MENU   | Select function | Select option & print next item
TEAROFF| Select function | Select option & print previous item
LOAD   | Move cursor to the right | Move cursor right to the next option
LF/FF  | Move cursor to the left | Move cursor left to the previous option

<<FUNCTION>>
SAVE&END MENU1 MENU2 HARDWRE ADJUST CONFIG DEFAULT LIST SELF-TST HEX-DUMP
V-ALMNT
  
```

Cursor ———

————— HARDWRE

Example of changing hardware

3. Use the <LF/FF> or <LOAD> key to move the cursor to the point which is to be changed, 'MENU 1', 'MENU2', 'HARDWRE', 'ADJUST', or 'CONFIG'.
4. Press <MENU>.
 - ⇒ The first setting is printed.

5. Use <LF/FF> or <LOAD> keys under the value you require (see table) to move the cursor.
6. Press <MENU>.
 - ⇒ The setting selected is fixed and the next setting printed.
7. Proceed as described here for the other selections.
8. To exit the menu, move the cursor under the text 'SAVE & END' and press <MENU>.
9. To close, press <ONLINE>.
 - ⇒ The 'ONLINE' LED lights up.
10. Switch the printer off and on again.
 - ⇒ The changes are activated and the printer ready to operate.

10 List of items

Item		Manufacturer
Printer	Fujitsu DL3750+	Fujitsu Siemens item number: A5Q00023962
RS232 module	FCA2001-A1	Siemens Siemens item number: A5Q00005327
Print server	PS01a: M04120	SEH http://www.seh.de
Connector, 25-pole, shielded	DB-25, male: ISO 2110	
	e.g.: housing 3357-6225-1C	3M
	Insert F25P0G2	FCT
Socket, 9-pole, shielded	DE-9: EIA/TIA-574, female	
	e.g.: Housing 3357-6209-1C	3M
	Insert F09S0G2	FCT
3-wire cable, max. 150 Ω /km (maximum length 15 m) version with copper netting shield	e.g.: D315FRNC 3-wire minimum 0.14 mm ²	SABIX

Issued by
Siemens Switzerland Ltd
Infrastructure & Cities Sector
Building Technologies Division
International Headquarters
Gubelstrasse 22
CH-6301 Zug
Tel. +41 41-724 24 24
www.siemens.com/buildingtechnologies

© 2006-2012 Copyright Siemens Switzerland Ltd
Technical specifications and availability subject to change without notice.