

N 258/02 Temperature Sensor 4x Pt1000
5WG1 258-1AB02

Product and Applications Description

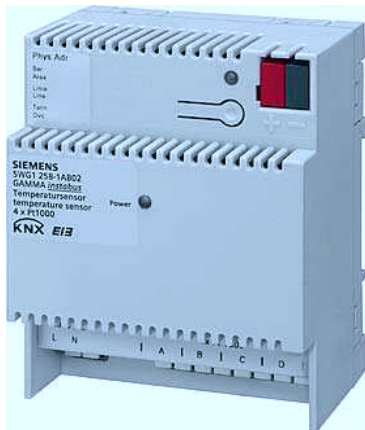

The temperature sensor N 258/02 is a device for DIN rail mounting, in N-system dimensions with a width of 4 module units, with 4 inputs for the direct connection of a Pt1000 temperature sensor each by a two-core cable up to 50 m long. It enables the recording and monitoring of up to 4 temperatures in the range $-35\dots+145\text{ }^{\circ}\text{C}$. The sensor electronics is powered by an integrated power supply for AC 230 V. The connection to the bus line can be carried out either via a bus terminal block or by a contacting system to a data-rail installed in the DIN-rail. Terminal block and contacting system are connected to each other inside the device.

Application Program

The application program „25 S4 4xPt1000 Sensor 981401“ can be loaded with ETS2 version 1.3 and higher. The temperature is measured cyclically per measurement channel (with a fixed cyclic period of 1 s). It can be set via the ETS (Engineering Tool Software) whether the measured value should be filtered by mean-value generation. Each measured value can be monitored for one lower and one upper limit value or for two lower and two upper limit values. It is ensured via an adjustable symmetric hysteresis that a measured value that fluctuates by the limit value does not lead continuously to a coming and going violation of the limit value with corresponding messages.

In addition to the automatic sending of a measured value after a change by an adjustable differential value and the automatic sending of a coming or going limit value violation, it is possible to set whether the current temperature value as well as the status of the limit value objects should be sent cyclically and with which cyclic period. It

can also be configured separately per channel whether the current temperature value and / or the status of the limit value objects should be sent after a bus voltage or mains voltage recovery.

Connection example

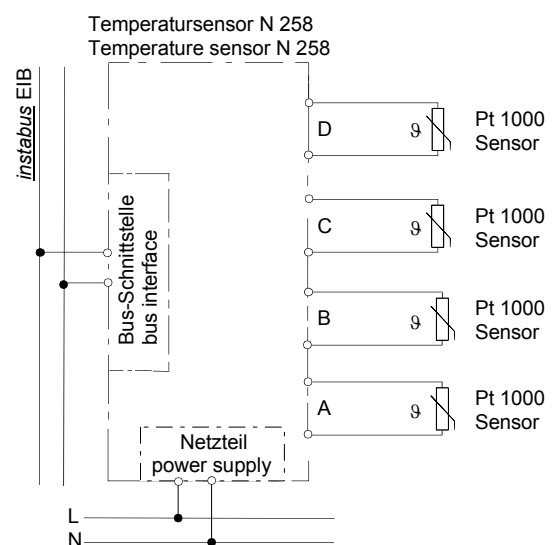

Notes for installation

The device may be used for permanent interior installations in dry locations within distribution boards or small casings with DIN rail EN 60715-TH35-7.5.



DANGER

- The application of an AC or DC voltage to an input may lead to the damage / destruction of the input / device.
- The device must be mounted and commissioned by an authorized electrician.
- When connecting the device, it should be ensured that the device can be isolated.
- The device must not be opened.
- When planning and installing electrical systems, the appropriate guidelines, regulations and specifications of the respective country must be taken into account.

Technical Specifications

Power supply

- Bus voltage: carried out via the bus line
- Bus current: 5 mA (only half a standard bus load !)
- Electronics: integrated power supply unit for AC 230V, +10% / -15%, 50/60 Hz, power consumption: 2.5 W
- Supply voltage for bus: 21V DC to 30V DC

Inputs / outputs

- Mains connection: 2 pole (N, L)
- 4 inputs for the connection of one Pt1000 temperature sensor each in 2-conductor technology, max. cable length: 50 m, measuring range: -35...+145 °C, measured value resolution: 0.1K in the range +5...+45 °C and 0.25K in all other ranges, measuring accuracy: ± 0.5 K

Connections

- Plug-in terminals for mains voltage and Pt 1000 sensors, insulation strip length 9 ... 10 mm
- The following conductor cross-sections are permitted for the connections of the mains voltage and of the sensors:
 - 0.5 ... 2.5 mm² single core
 - 0.5 ... 1.5 mm² finely stranded with connector sleeve
 - 1.5 mm² finely stranded, untreated
- Bus line:
 - Pressure contacts on data rail
 - Screwless bus terminal 0.6 ... 0.8 mm \varnothing single core (strip approx. 5 mm of insulation from the conductor and insert in the bus terminal: red = +, grey = -)

Mechanical data

- Housing: plastic
- Dimensions: DIN rail mounted device in N-system dimensions, width 4 Module Units (1 MU = 18 mm)
- Weight: approx. 200 g
- Fire load: 3400 kJ ± 10 %
- Mounting: Snap-on mounting on DIN rail EN 60715-TH35-7.5

Electrical safety

- Degree of pollution (according to IEC 60664-1): 2
- Type of protection (according to EN 60529): IP 20
- Overvoltage category (according to IEC 60664-1): III
- Bus: Safety extra-low voltage SELV DC 24 V
- Device complies with EN 50090-2-2

EMC requirements

- Complies with EN 50090-2-2 and EN 61000-6-2

Environmental conditions

- Climatic withstand capability: EN 50090-2-2
- Ambient operating temperature: - 5 ... + 45 °C
- Storage temperature: - 25 ... + 70 °C
- Rel. humidity (not condensing): 5 % to 93 %

Markings

KNX EIB

Location and Function of the Display and Operating Elements

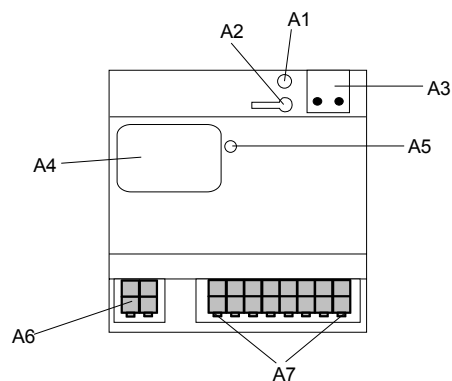

Figure 1: Location of the display and operating elements

- A1 Commissioning LED (red)
- A2 Commissioning button
- A3 Bus terminal
- A4 Name plate
- A5 LED (green) to display the 230 V operating voltage
- A6 2 plug-in terminals (L,N) for AC 230 V mains power supply
- A7 4x 2 plug-in terminals for the connection of the four Pt1000 sensors

Mounting and wiring

General description

The DIN rail mounted device with N-system dimensions (4 module units) can be inserted in N-system distribution boards, either surface- or flush-mounted, and wherever EN 50022-35 x 7.5 mounting rails are available. The contact with the bus line is carried out via the bus terminals or via the contact system to the data rail.

Assembling the DIN rail mounted device (Figure 2)

- Place the device (B1) on the DIN rail (B2) and
- rotate the device downwards until the slide switch audibly clicks into position.

Dismantling the DIN rail mounted device (Figure 2)

- Remove all the connected cables,
- press the slide switch (C3) down with a screwdriver and
- remove the device (C1) from the DIN rail (C2) with a swivel action.

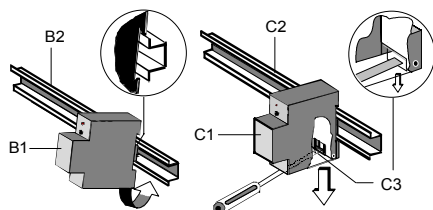

Figure 2: Assembling and dismantling the DIN rail mounted device

Removing the bus terminal (Figure 3)

- The bus terminal (D2) is located on the top of the device (D1)
- The bus terminal (D2) consists of two sections (D2.1, D2.2), each with four terminal contacts. Care should be taken not to damage the two test sockets (D2.3) either by accidentally connecting them to the bus conductor or with the screwdriver when attempting to remove the bus terminal.
- Carefully insert the screwdriver in the wire entry slot underneath the bus terminal (D2) and pull the bus terminal forwards out of the device (D1).

Note

When removing the bus terminal, there is a danger of short circuits !

Plugging in the bus terminal (Figure 3)

- Place the bus terminal (D2) in the guide slot and press downwards until it reaches the stop.

Connecting the bus cable (Figure 3)

- The bus terminal (D2) is suitable for single-core conductors with 0.6 ... 0.8 mm Ø.
- Strip approx. 5 mm of insulation from the conductor (D2.4) and then plug in the terminal (D2) (red = +, black = -).

Disconnecting the bus cable (Figure 3)

- Remove the bus terminal (D2) and the conductor (D2.4) from the bus cable by rotating them simultaneously backwards and forwards.

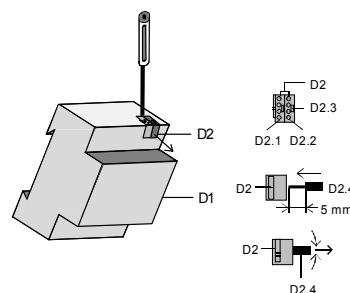

Figure 3: Connecting and removing the cable

Connecting the mains voltage

- The connections are carried out with plug-in terminals.
- Strip approx. 9-10 mm of insulation from the conductor and slide into the respective terminal.

Mounting the insulating cap

If the device should be mounted on a DIN rail without an data rail, the contact system must be covered with the supplied insulating cap.

Removing the locating clamp: (Figure 4)

- The locating clamp (E3) encloses the contact system (E2) on the rear of the device (E1).
- Insert the screwdriver between the DIN rail mounted device (E1) and the locating clamp (E3) and remove the clamp.

Clipping on the insulation cap: (Figure 4)

Place the insulating cap (E4) on the contact system (E2) and press so that it snaps in place.

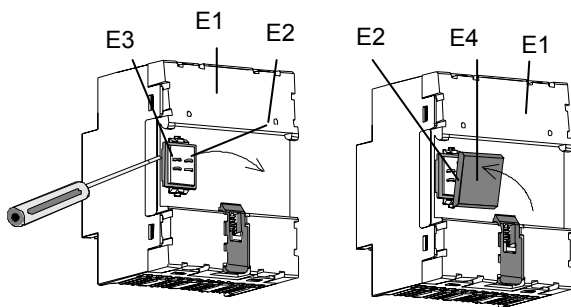
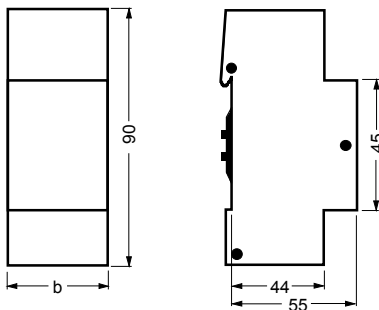

Figure 4: Covering the contact system

Dimension drawing

Dimensions in mm



b = 4 module units

1 module unit = 18 mm

General Notes

- Any faulty device should be returned to the local Siemens office.
- If you have further questions concerning the product please contact our technical support.

☎ +49 (0) 180 50 50-222

☎ +49 (0) 180 50 50-223

✉ www.siemens.com/automation/support-request