

## Product and functional description



The UP 258D11 is a presence/motion detector with integrated 2-point light control. The UP 258D11 device communicates via KNX/EIB with actuators or other KNX devices. It is designed for mounting on the ceiling. Owing to its tilting sensor head, the UP 258D11 can be aligned with the required capture area. The main application for the device is automatic lighting control in an office workplace.

The UP 258D11 senses the presence of a person or that there is no longer anyone in its detection area. The detector signal can be analyzed via two separate communication channels, termed motion detector and presence detector.

Additionally, the UP 258D11 provides an output for control of HVAC applications. For example, this function can switch systems that are used for heating, ventilating and air-conditioning control (HVAC) of the room from "Energy saving mode" in an unused room to "Comfort mode" in an occupied room and back to "Energy saving mode" when the room is again unoccupied.

For each detector function block (presence, motion, HVAC) 4 communication objects are available, in total 12 different communication objects. Depending on configuration, one or two KNX telegrams are sent onto the bus when motion is first detected and when, after the last motion was detected, an overshoot time has expired. The values of the communication objects are configured for each functional block (motion detector, presence detector, HVAC-detector) via corresponding parameters.

Each time a presence is detected, the overshoot time is started. Its duration is separately configurable for each functional block. The end of presence is determined by the end of the overshoot time.

The duration of the dead time is also configurable per functional block. It is used to protect the actuators that are connected to the detector. If a presence is detected during the dead time, neither telegrams are sent nor the overshoot time is started.

In the following the telegrams, which are sent at the beginning of a presence, are called **A** and **B**, the telegrams, which are sent at the end of a presence, are called **C** and **D**.

### Operating Sequence

After the device has detected a presence, telegram **A** is sent immediately. If it has been configured to send also a telegram **B**, then telegram **B** is sent after the configured time (optionally also cyclically).

If there are no motions any more, at the end of the overshoot time telegram **C** and (if configured) telegram **D** are sent. Telegram **D** can also be sent cyclically.

If there are motions while the overshoot time is running, the overshoot time is restarted.

### Flowchart:

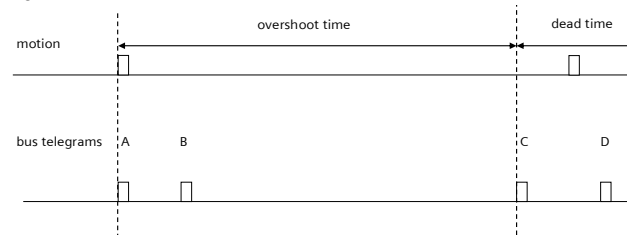

### Use as single device or as main detector (master), respectively secondary detector (slave)

The detector can be operated as an independent device, as the main or secondary detector.

According to the requirement, additional presence detectors can be connected with the "main detector" via KNX/EIB as "secondary detectors" to extend the presence detection zone. "Secondary detectors" supply motion information only to the main detector.

### Brightness measuring – adjustable via KNX/EIB

The UP 258D11 contains an independent light sensor. The signal measured there is available both at the KNX/EIB and internally.

Because the light sensor measures directly, it must be possible to calibrate it for indirect measurement, so that it can be adapted to the different installation sites. Rapid

brightness fluctuations are filtered out. The measurement range of the internal light sensor is between 20 and 1000 lux.

The settings determine whether the brightness value computed by the device or a brightness value received from outside is used for the detector's remaining functional blocks.

**Integrated light control (on – off)**

If the brightness controller is enabled (automatic mode) the lighting is switched on as soon as the brightness falls below a set lower threshold. The lighting is switched off if the set upper brightness threshold is exceeded. The brightness thresholds are variable either via parameters or via communication objects.

The controller can also be operated semi-automatically by separating into two individual switching objects for exceeding or falling below the threshold. In this way, it can be switched to "Only on" or "Only off."

If the controller receives a switching or dimming command via the associated communication object over KNX/EIB, then this is deemed an external override and the controller switches automatic mode off. This change of status is sent simultaneously on the bus via the "Automatic Status" object.

**Operation via infrared (IR) remote control**

The IR receiver integrated in the presence detector can control light and shade, as well as store and call up scenes via a special IR remote control.

The IR commands implemented can be combined via communication objects with the other function blocks or used to control other devices.

The IR decoder can be controlled only with one of the Siemens IR remote controls shown in figure 1. The remote controls have a range of 5 meters maximum.

The IR decoder cannot distinguish between remote controls. The functionality of button pairs A to F (see diagram in figure 1) will be configured via the ETS.

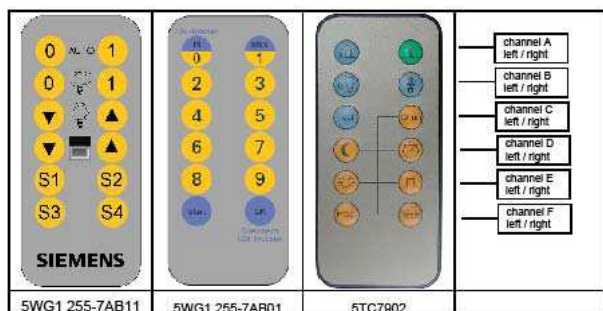

Figure 1. IR remote control units for UP 258D11

**Commissioning / Factory default settings**

After the device is connected to the bus voltage, the sensor must first "Restart". In this phase, the programming LED flashes double.(¼sec. ON → ¼sec. OFF → ¼sec. ON → 1¼sec. OFF →...)

After "Restart" of the sensor, it appears that no motion is detected at present, the programming LED is off.

**Factory default settings**

In the as delivered state, the parameter Operating Mode is set to Setting Mode.

While the device is in "Setting Mode", the integrated programming LED displays the PIR sensor state. (illuminates briefly with motion)

**Note:**

The programming LED can be recognized more easily without the design cover!

If the device is in programming mode, the LED stays on and does not flash. The PIR state is then not displayed.

The programming mode can be set in factory default status also with the available IR remote control S 255/11 (S3 = On / S4 = Off). This feature is available in firmware version V02 (see figure 2: A11) and higher.

If the device was downloaded once by ETS, the programming mode can be enabled and disabled with the programming button on the device.

**Programming mode**

Press the programming key short (< 0,5 s) to enable programming mode. This is indicated by the programming LED.

**Factory setting**

When the programming key is pressed very long (> 20 s) the device is reset to the default factory settings. This is indicated by evenly flashing the programming LED. The flashing stops after 5 seconds.

**Behavior after programming**

The behavior of the device after programming with the ETS is dependent on the configuration. The description of the features, parameters and objects is in the application program description of the device.

**Note:**

When the programming key is pressed longer (> 0,5 s to 2 s) no functions are activated.

When the programming key is pressed longer (> 2 s) the device starts connection test. This is a special mode for Desigo TRA. The device June be blocked for the manufacturer specific functions for approx. 10 seconds for the programming mode. This is indicated by briefly flashing the programming LED.

UP 258D11 OPTISENS OFFICE Presence detector / motion detector

5WG1 258-2DB11

**Application program**

25 CO Presence detector with light control - 910501

The following features are integrated in the device:

- Brightness measurement as mixed light measurement; Calibration via bus
- Integrated 2-point brightness controller (switching)
- Presence and motion detection
- Operation as an individual sensor or as the main or ancillary sensor for covering wider areas.
- Separate output (as a KNX - object) for heating, ventilation and air conditioning applications.
- Selectable functions for presence, motion, and HVAC detector function blocks:
  - Switching On/Off
  - 8-bit value (0...255)
  - 16-bit value (0...65535)
  - 16-bit-value (temperature) (0°C – 40°C)
  - 16-bit-value (brightness) (0 – 2000Lux)
  - 8-bit scene
- Integrated IR-receiver for a IR-remote control (see accessories)
- Selectable functions per IR pair of pushbuttons:
  - Switching On/Off/toggle
  - 8-bit value (0...255)
  - 16-bit value (0...65535)
  - 16-bit-value(temperature) (0°C – 40°C)
  - 16-bit-value (brightness) (0 – 2000Lux)
  - 8-bit scene

The KNX Engineering Tool Software (ETS) version 3.0 f is required to load the application program.

**Installation notes****DANGER**

- The device must be mounted and commissioned by an authorized electrician.
- When connecting the device, it should be ensured that the device can be isolated.
- The device must not be opened.
- For planning and construction of electric installations, the relevant guidelines, regulations and standards of the respective country are to be considered.

**Technical data****Power supply**

- via bus line
- Current drain approx. 10 mA

**Presence detection**

- Type: Passive infrared (PIR)
- Range: horizontal 360°,

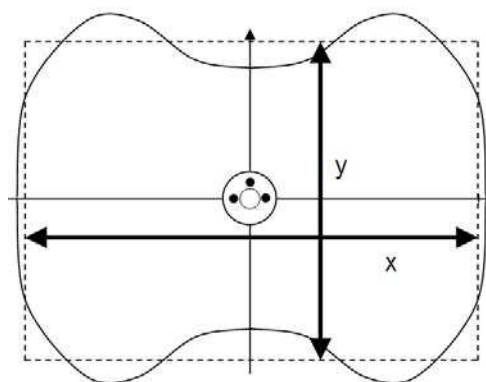

Detection range (m)		
l	x	y
2,50	4,5	3
2,75	5	3,5
3,00	6,5	3,7
3,25	7	4
3,50	7,5	4,2
3,75	8	4,5

**Notes:**

- Installation height (l) in Meter
- Averaged detection range (x, y) for walking or sitting persons in meter +/- 1 m
- Be aware of orientation of presence detector, visible at position of programming button (fig. 2 - A7)
- with design cover, without shade, in vertical position
- Recommended mounting height for mixed light measurement: 2,5m – 2,8m

**Brightness measurement**

- Type: Mixed light measurement
- Measuring range: 20...1000 Lux

**IR receiver**

For remote control (see accessories)

max. Distance detector <--> remote control: ~ 4.5 m

**Operating elements**

- 1 commissioning push button:  
for toggling between normal mode / addressing mode
- for reset the device to the default factory settings and to activate manufacturer specific functions

**Display elements**

- 1 red LED: for checking the bus voltage and for displaying normal mode / addressing mode
- This LED indicated also the reset to the default factory settings and further activated manufacturer specific functions.
- This LED also indicates presence / motion detection in test mode .

**Connections**

- KNX bus line: bus terminal block

**Mechanical specifications**

- Housing: plastic
- Dimensions (DxT):  
; 53 mm x 31 mm (without design cover)  
; 88 mm x 63 mm (with design cover)
- Weight: approx. 70g
- Fire load: approx. 2480 kJ
- Installation: in flush mounting box, ceiling opening, or in surface mounting box (see accessories)

**Electrical safety**

- Degree of pollution (according to IEC 60664-1): 2
- Type of protection (according to EN 60529): IP 20
- Overvoltage category (according to IEC 60664-1): III
- Bus: safety extra-low voltage SELV DC 24 V
- Device complies with: EN 60669-2-1

**EMC requirements**

- Complies with EN 50428

**Environmental conditions**

- Climatic withstand capability: EN 50090-2-2
- Ambient operating temperature: - 5 ... + 45 °C
- Storage temperature: - 20 ... + 70 °C
- Relative humidity (not condensing): 5 % to 93 %

**Reliability**

- Failure rate: 410 fit at 40°C

**Markings**

- KNX *EIB*

**CE mark**

- In accordance with the EMC guideline (residential and functional buildings), low voltage guideline

**Accessories**

- IR - remote control S 255/11                    5WG1 255 – 7AB11
- AP - housing AP 258E01                        5WG1 258 – 7EB01

**Location and function of the display and operating elements**

Figure 2: Display and operating elements

- A1 UP 258D device
- A2 Fixing clamps
- A3 adjustable sensor head
- A4 PIR - sensor
- A5 Brightness sensor
- A6 IR receiver for remote controls
- A7 LED (red) and programming key
- A8 Shade
- A9 Design cover
- A10 Bus terminal
- A11 Firmware version V0x
- A12 Barcode label with KNX serial number and supplier code

## Installation and wiring

### Mounting site

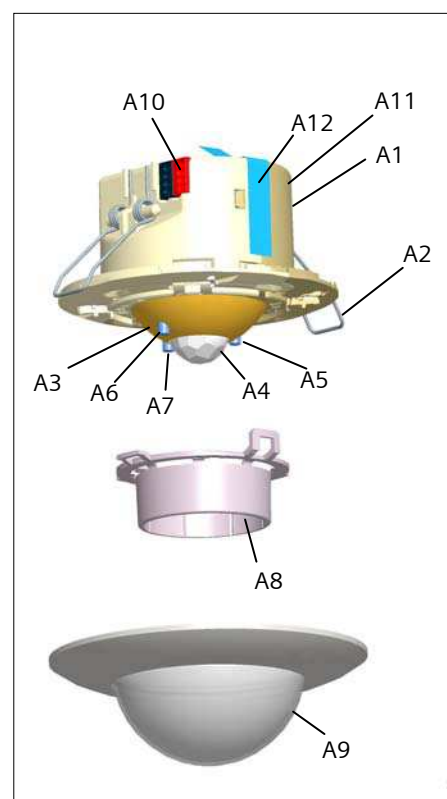
The device is designed for ceiling mounting.  
Recommended mounting height: 2,5m – 2,8m

### → **Brightness measurement in particular**

The daylight measurement determines an average brightness value in the room, which can differ from the brightness on the worktop. You should therefore avoid mounting sites with extreme light ratios.  
If the detector is fitted near lights with a high proportion of indirect light, the artificial light level at the detector mounting point must not exceed the wanted nominal lighting level in the room. This can be compensated by increasing the separation between the light cone and the detector. For constant lighting control, direct artificial light on the detector should be avoided.

### → **Presence-motion detection in particular:**

Normally, the switching pattern is determined by people in the detector's catchment area.  
In exceptional cases, however, it can be switched on inadvertently through "outside factors". Accordingly, potential "sources of interference" should be considered or removed during planning or before mounting.

### Basics:

- The PIR - sensor reacts to temperature differences.
- The lower the temperature difference between the ambient temperature and the moving object, the less sensitive the analysis. In other words, moving objects will not then be detected as efficiently and the catchment area is restricted.

### Note:

- There must be an unobstructed line of sight to the person in the catchment area. People behind walls, etc. (including glass) cannot be detected!
- Obstacles such as party walls, plants or shelves can limit the catchment area.
- Hanging lights cause shadows in the catchment area if they are mounted in the immediate vicinity of the presence detector.

### Interference factors to be avoided:

- Rapid temperature changes in the vicinity of the detector, caused by fan heaters being switched on or off, fans, etc., simulate motion.
- Lights being switched on or off in the immediate catchment area (mainly incandescent and halogen lamps) simulate motion.

- Moving objects such as machines, robots, hanging posters, falling flower petals, hot paper from laser printers, animals, etc.
- The mounting site must not be exposed to vibrations or motion.

Mounting

The following mounting options are possible:

- Flush mounting (A) with screw fixing in a flush mount box
- Flush mounting (A) with fixing claws in suspended ceiling
- Surface mounting (B) in the surface mounted housing (see accessories)

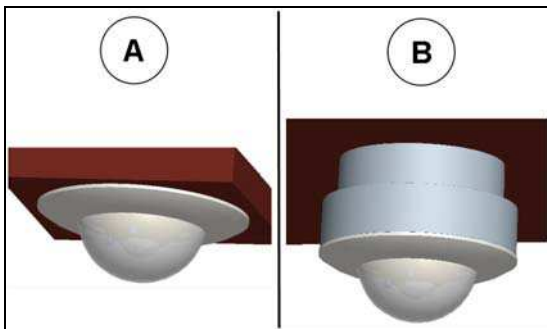

Figure 3: Mounting options

Connection of the detector to the bus

Connecting:

Plug wires into the bus terminal. Ensure you have stripped the insulation back!  
Push the bus terminal on the plug in the device (see figure 4)

Disconnecting:

Separate the bus terminal from the device (use a screwdriver if necessary)  
Separate the wires from the bus terminal by turning.

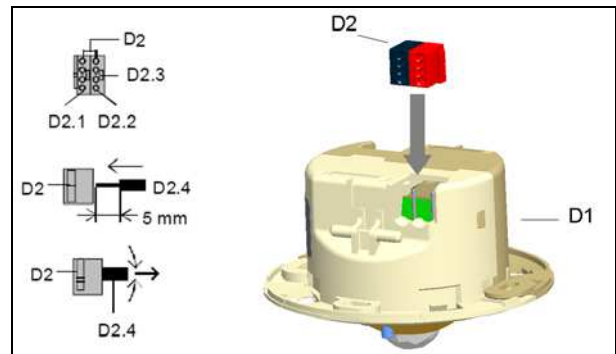

Figure 4: Connecting the detector

- D1 UP 258D device
- D2 Bus terminal
- D2.1 (-) Terminal (grey)
- D2.2 (+) Terminal (red)
- D2.3 Test contact
- D2.4 Bus line wire

Installation in flush-mount box using screws

The device is secured with fixing screws in the UP socket.  
The device can be installed offset by 90° with the additional fixing holes.

**Note:**

- Fixing clamps must not be mounted!

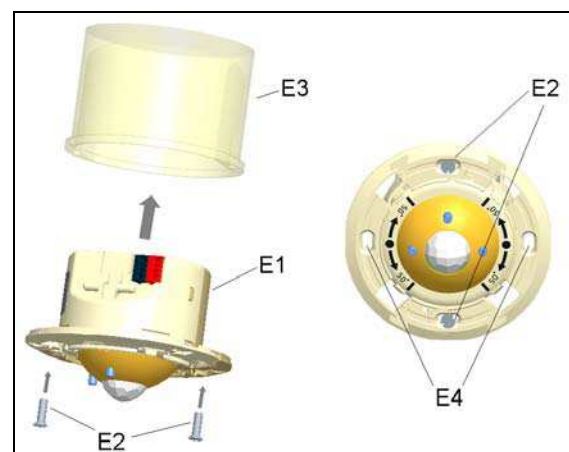

Figure 5: Installation in flush-mount box using screws

- E1 UP 258D device
- E2 Socket fixing screws
- E3 UP socket Depth: min. 40 mm, Ø 60 mm)
- E4 Additional fixing holes offset by 90°

UP 258D11 OPTISENS OFFICE Presence detector / motion detector

5WG1 258-2DB11

Mounting the fixing clamps for mounting the device in suspended ceilings  
 Extend the fixing claws slightly and push over the lugs on the UP 258D.

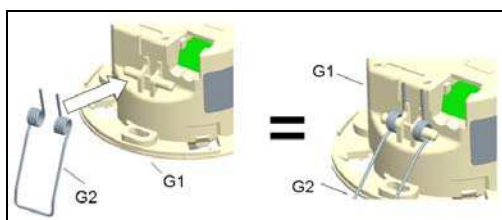

Figure 6: Mounting the fixing clamps for mounting the device in suspended ceilings

- G1 UP 258D device
- G2 Fixing clamp

Installation in suspended ceilings with fixing clamps  
 Press the fixing clamps together (see figure 7) and push the device into the opening (Ø 60mm - 65 mm) with the fixing clamps in front.  
 The fixing clamps hold the device on the ceiling.  
 Max. thickness of the suspended ceiling: 30mm

**Caution:**

- When unmounting the device hold it where the two housing parts are joined together. Otherwise, the fixing clamps June hit your fingers.

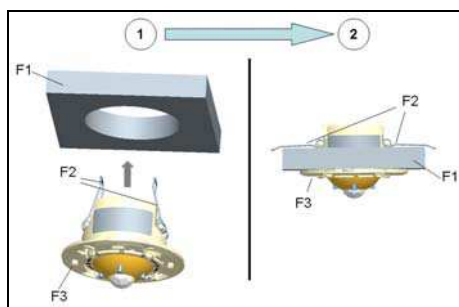

Figure 7: Installation in suspended ceilings with fixing clamps

- F1 Suspended ceiling (max. thickness of the suspended ceiling: 30mm)
- F2 Fixing clamps
- F3 UP 258D device

Adjusting the detector

The sensor head can be turned to ±50°. (see figure 8.1)

It is also possible, of course, to install the detector offset by 90° with the additional fixing holes. The adjustable sensor head can be tilted about the vertical from -5° to +25° (see figure 8.2).

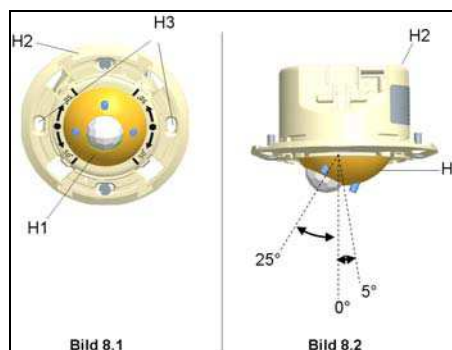

Figure 8: Adjusting the detector

- H1 adjustable sensor head
- H2 UP 258D device
- H3 Additional fixing holes

Mounting / Dismounting the shade

The shade is used in the packed state as transport protection for the tilting sensor head. It can be removed before mounting the detector.

Separate the snaplock hooks on the shade with a screwdriver and fold the shade down.

If you want to constrain the detection area, you can cut out the shade. The shade can be clipped back on if need after mounting the detector.

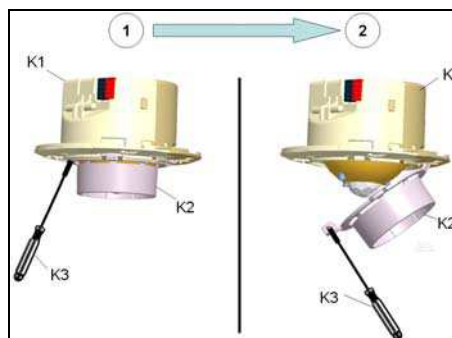

Figure 9: Mounting / Dismounting the shade

- K1 UP 258D device
- K2 Shade
- K3 Screwdriver

Cutting the shade

The shade is cut out in the wanted sectors with sidecutters or a knife.

**Caution:**

- Do not cut out the mounted shade!  
Only cut out the dismantled shade!

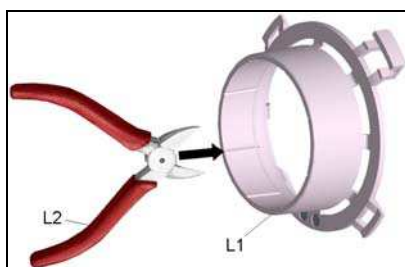

Figure 10: Cutting the shade

- L1 Shade
- L2 Sidecutter

Mounting the design cover

The design cover is clipped on to the device from below, until the snaplock hooks on the design cover engage on the outer edge of the device with an audible click.

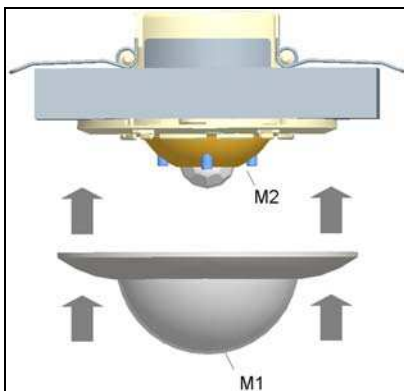

Figure 11: Mounting the design cover

- M1 Design cover
- M2 UP 258D device

Dismounting the design cover

The design cover is dismantled by pulling downwards. Use a screwdriver to help with this operation.

**Caution:**

- Be careful when handling the screwdriver. There is a risk of scratching the ceiling or the design cover. Accordingly, be gentle while working

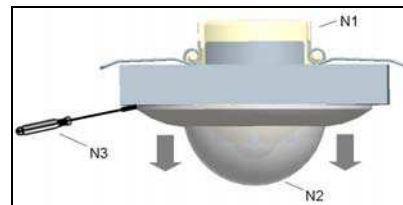
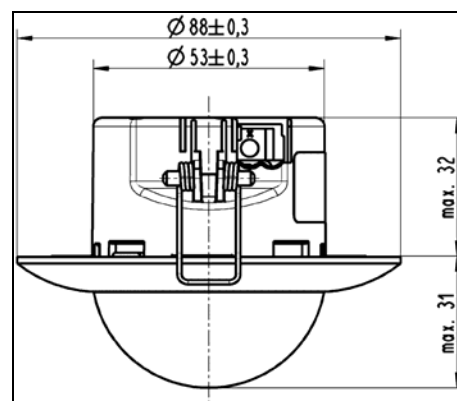

Figure 12: Dismounting the design cover

- N1 UP 258D device
- N2 Design cover
- N3 Screwdriver (caution)

**Dimension drawing**

Dimensions in mm





UP 258D11 OPTISENS OFFICE Presence detector / motion detector

5WG1 258-2DB11

**General notes**

- The operating instructions must be handed over to the client.
- Any faulty device is to be sent together with a return delivery note of the local Siemens office.
- If you have further questions concerning the product please contact our technical support.

☎ +49 (911) 895-7222

☎ +49 (911) 895-7223

✉ support.automation@siemens.com

[www.siemens.de/automation/support-request](http://www.siemens.de/automation/support-request)**Note:**

---

This product supports two different operation modes: KNX und PL-Link.

This document describes the KNX functionality that can be configured with ETS.

For PL-Link refer to documentation for Desigo.

---