

DELTA i-system	Motion detector	UP 258	5WG1 258-2HB_
DELTA profil	Motion detector	UP 255	5WG1 255-2AB_
DELTA style	Motion detector	UP 257	5WG1 257-2AB_
DELTA ambiente	Motion detector	UP 256	5WG1 256-2AB_



Product	DELTA i-system		DELTA profil	
Motion detector 1,10 m	titanium white	5WG1 258-2HB11	pearl grey	5WG1 255-2AB01
	carbon metallic	5WG1 258-2HB21	titanium white	5WG1 255-2AB11
	aluminum metallic	5WG1 258-2HB31	anthracite	5WG1 255-2AB21
Motion detector 2,20 m	titanium white	5WG1 258-2HB12	silver	5WG1 255-2AB71
	carbon metallic	5WG1 258-2HB22	pearl grey	5WG1 255-2AB02
	aluminum metallic	5WG1 258-2HB32	titanium white	5WG1 255-2AB12
Frames	ordered separately from the DELTA ranges			
	---		cut out frames	
Bus coupling unit	UP 110; UP 114			



Product	DELTA style		DELTA ambiente	
Motion detector 1,10 m	titanium white	5WG1 257-2AB13	arctic white	5WG1 256-2AB01
	basalt black	5WG1 257-2AB21		
	platinum metallic	5WG1 257-2AB41		
Motion detector 2,20 m	titanium white	5WG1 257-2AB14	arctic white	5WG1 256-2AB02
	basalt black	5WG1 257-2AB22		
	platinum metallic	5WG1 257-2AB42		
Frames	ordered separately from the DELTA ranges			
Intermediate frame	5TG1 368 basalt black			
Bus coupling unit	UP 110; UP 114			

DELTA i-system	Motion detector	UP 258	5WG1 258-2HB_
DELTA profil	Motion detector	UP 255	5WG1 255-2AB_
DELTA style	Motion detector	UP 257	5WG1 257-2AB_
DELTA ambiente	Motion detector	UP 256	5WG1 256-2AB_

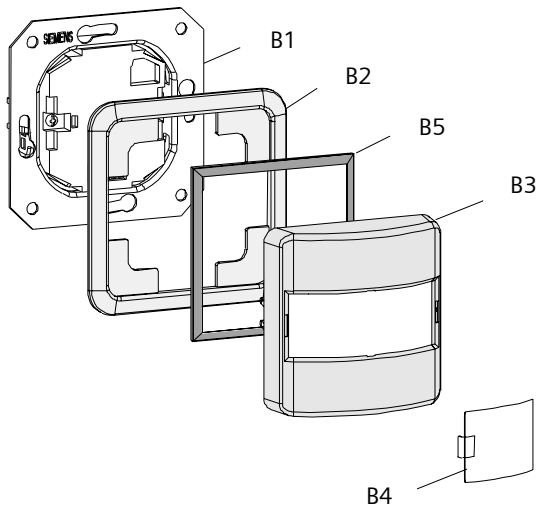

Diagram 1: Installing the motion detector

- B1 Bus coupling unit UP
- B2 Frame
- B3 Motion detector \*)
- B4 Detachable masking plate \*)
- B5 Intermediate frame  
(only for DELTA style basalt black)

\*) Lieferumfang

**Product and Applications Description**

The motion detector UP 255 / UP 256 / UP 257 / UP 258 is a proximity sensor which reacts to movements of people, animals or other moving objects. If a motion is detected the corresponding telegrams are sent on the bus. It is used for example to detect people moving in its monitoring area. Using an appropriate application program, it gives switching commands via the flush-mounted bus coupling unit to actuators such as binary outputs to switch groups of luminaries or to signalling units. The motion detector can be operated in stand-alone mode, as a master or extension unit.

**Note:**

The device is not fitted to be used in connection with alarm systems.

It is placed on the flush-mounted bus coupling unit, together with the relevant frame and is only operational when used together with the bus coupling unit and the corresponding application program i.e. the motion detector UP 255 / UP 256 / UP 257 / UP 258 (with flush-mounted bus coupling unit] consists of the device (hardware) and the application program (software). The flush-mounted bus coupling unit and the relevant frame are not included with delivery and must be ordered separately. When using DELTA style a tier frame must be employed.

Using the detachable masking plate supplied (B4), it is possible to reduce the detection range on the left or right.

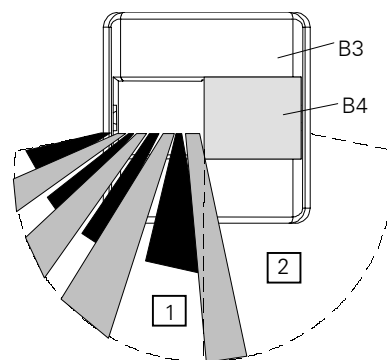

Diagram 2: Reducing the detection range

- 1 Detection range
- 2 Screened range
- B3 Motion detector
- B4 Detachable masking plate

Using the ETS software, it is possible to select the application programs and assign the specific parameters and addresses.

DELTA i-system	Motion detector	UP 258	5WG1 258-2HB_
DELTA profil	Motion detector	UP 255	5WG1 255-2AB_
DELTA style	Motion detector	UP 257	5WG1 257-2AB_
DELTA ambiente	Motion detector	UP 256	5WG1 256-2AB_

## Application Programs

### 12 S1 Mot.detect. standalone 211D01

- Brightness level can be set
- Cyclical sending is possible
- Overshoot time, dead time and blocking function

### 12 S1 Mot.detect. central 211E01

- Can be configured as a master unit in the case of multiple operation
- Brightness level can be set
- Cyclical sending is possible
- Dead time and blocking function can be assigned

### 12 S1 Mot.detect. branch 211F01

- Can be configured as an extension input in the case of multiple operation
- Brightness level can be set
- Overshoot time, dead time and blocking function

## Installation Instructions

- The device can be used for permanent interior installations, in dry rooms and for insertion in flush-type boxes.



### DANGER

- The device may only be installed and commissioned by an authorized electrician.
- The device may not be inserted in the same box as 230 V devices.
- The device may be used in switch sockets, if VDE approved devices have been used.
- The prevailing safety and accident regulations must be observed.
- The device may not be opened.
- For planning and construction of electric installations, the relevant guidelines, regulations and standards of the respective country are to be considered.

## Technical data

### Power supply

- via the flush-mounted bus coupling unit

## Operating elements

- Potentiometer for step less adjustment of the range between 100% and 20%

## Properties

- Light sensor: adjustable in steps from approx. 1 ... 1000 lx (daylight mode to night mode)
- Horizontal detection angle: 180 degrees on two levels (can be reduced to 90° on the left or right using a detachable masking plate)
- Range for mounting height of 1.10 m: approx. 10 m
- Range for mounting height of 2.20 m: approx. 10 m
- Lateral range: 2 x approx. 6 m each side
- Optical system: Fresnel lens (2 levels with 18 segments)

## Connections

- 10-pole plug connector (PEI): for connection to the flush-mounted bus coupling unit

## Physical specifications

- Housing: plastic
- Dimensions (L x W x D):  
68 x 68 x 23 mm / 65 x 65 x 23 mm / 55 x 55 x 23 mm
- Weight: approx. 45 g
- Fire load: approx. 750 kJ ± 10 %
- Mounting: clipped onto the flush-mounted bus coupling unit
- Mounting height: 1.10 m / 2.20 m

## Electrical safety

- Degree of pollution (according to IEC 60664-1): 2
- Type of protection (according to EN 60529): IP 20
- Protection class (according to IEC 61140): III
- Overvoltage category (according to IEC 60664-1): III
- Bus: safety extra-low voltage SELV DC 24 V
- Device complies with EN 50 090-2-2 and EN 60669-2-1

## EMC requirements

- complies with EN 50090-2-2

## Environmental conditions

- Climatic withstand capability: EN 50090-2-2
- Ambient temperature during operation: - 5 ... + 45 °C
- Storage temperature: - 25 ... + 70 °C
- Relative humidity (not condensing): 5 % to 93 %

## Markings

- KNX / EIB

DELTA i-system	Motion detector	UP 258	5WG1 258-2HB_
DELTA profil	Motion detector	UP 255	5WG1 255-2AB_
DELTA style	Motion detector	UP 257	5WG1 257-2AB_
DELTA ambiente	Motion detector	UP 256	5WG1 256-2AB_

**CE mark**

- in accordance with the EMC guideline (residential and functional buildings) and the low voltage guideline

**Location and function of the operating and display elements**

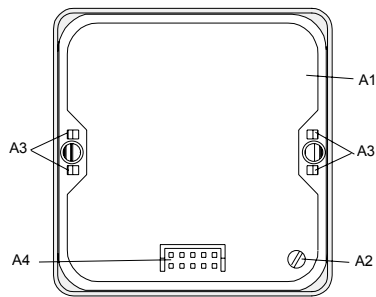

Diagram 3: Motion detector rear view:  
Location of the display and operating elements

- A1 Motion detector
- A2 Potentiometer for setting the range (left limit stop 20%, right limit stop 100%)
- A3 Mounting springs
- A4 10-pole plug connector (PEI)

**Representation of the detection ranges**

Mounting height type	Spatial view	Top view	Side view
1,10m			
2,20m			
Type 2,20 Mounting height 1,10			

Diagram 4: Representation of the detection ranges

DELTA i-system	Motion detector	UP 258	5WG1 258-2HB_
DELTA profil	Motion detector	UP 255	5WG1 255-2AB_
DELTA style	Motion detector	UP 257	5WG1 257-2AB_
DELTA ambiente	Motion detector	UP 256	5WG1 256-2AB_

## Mounting

### Note:

- The installation site and type of installation should be carefully selected according to the area that is to be monitored while considering any possible interference. The mounting wall should not be exposed to vibration or motion, as any movement of the motion detector has the same effect as thermal movement in the detection area. In order to prevent unwanted switching operations, the motion detector should if possible be installed so that it is not exposed to direct sunlight. Air turbulence caused by heaters, vents from air-conditioning units, dropping leaves of flowers etc. can also trigger switching operations in the monitoring area of the motion detector. Since infrared radiation is largely absorbed or reflected by glass, plastic, brickwork, metal and cardboard, it is not picked up by the motion detector.

Depending on the lamp type, fluorescent lamps and incandescent lamps may not be placed less than 1-3 m away from the motion detector in the detection area. Otherwise, the motion detector may be switched on again due to the thermal variation in the sensor range generated when the lamp is switched off.

- The optimum range is achieved if the sensor is mounted sideways to the direction of movement. There could otherwise be a reduction in the range.
- Sources of interference (lamps, heating systems etc.) should be excluded from the detection area (e.g. using the detachable masking plate).
- Sensors should not be aligned towards the sun. The high level of thermal energy can destroy the sensors.
- In the event of voltage recovery and after each programming process, it is necessary to wait for an immunity period of approx. 80 seconds before the motion detector is ready for operation again. No telegrams are sent by the motion detector during this time.

### General description

The motion detector is placed on the flush-mounted bus coupling unit together with the relevant frame (DELTA profil cut-out, DELTA ambiente or DELTA style with the relevant tier frame).

### Mounting sequence

- The flush-mounted bus coupling unit is connected and fixed in position in the flush-type box (see installation instructions for the flush-mounted bus coupling unit).
- If required, the uninstalled detachable masking plate (B4) is inserted on the left or right of the motion detector and induced to click into place by a strong pressure onto the 4 mounting clamps.
- It must not be forgotten to adjust the potentiometer for setting the range (A2) of diagram 2.
- Place the motion detector (B3) with the relevant frame (B2) on the flush-mounted bus coupler (B1).
- The brightness limit is set in the application program.
- It is possible to check the function of the detector or the detection area after programming by carrying out a walk test (according to detection area in Diagram 4). Before this the setting "maximum" has to be selected for the brightness and the setting "minimum" has to be selected for the switching interval in the parameter list.

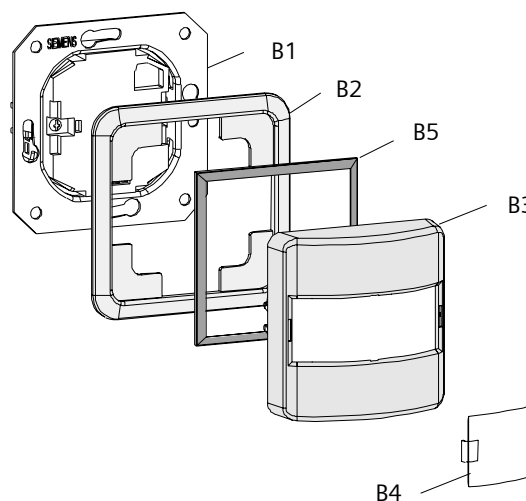

Diagram 4: Installing the motion detector

- B1 Flush-mounted bus coupling unit
- B2 Frame
- B3 Motion detector
- B4 Detachable masking plate
- B5 Intermediate frame  
(only for DELTA style basalt black)

DELTA i-system	Motion detector	UP 258	5WG1 258-2HB_
DELTA profil	Motion detector	UP 255	5WG1 255-2AB_
DELTA style	Motion detector	UP 257	5WG1 257-2AB_
DELTA ambiente	Motion detector	UP 256	5WG1 256-2AB_

## Dismantling

The motion detector (B3) together with the frame is manually removed from the flush-mounted bus coupling unit (B1).

If a modification of the viewing area is required, the detachable masking plate can be removed careful.

## Dimensions Diagram

DELTA i-system

Dimensions in mm

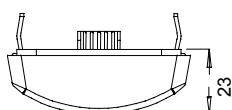
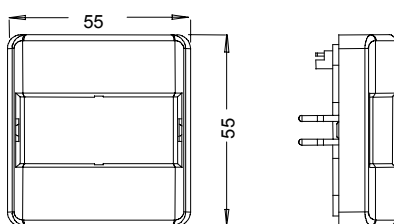

DELTA style (titanium white, platinum metallic)

Dimensions in mm

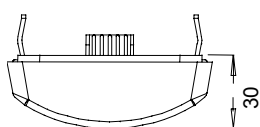
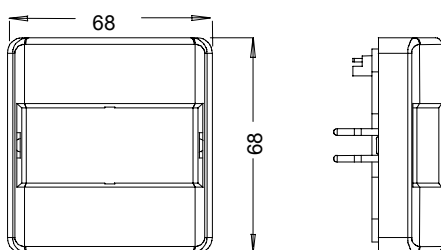

DELTA profil  
DELTA ambiente  
DELTA style (basalt black)

Dimensions in mm

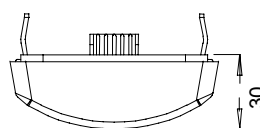
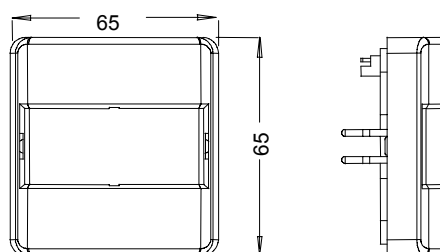

## General Notes

- The operating instructions must be handed over to the client.
- Any faulty device should be returned to the local Siemens office.
- If you have further questions concerning the product please contact our technical support:

☎ +49 (180) 5050-222

☎ +49 (180) 5050-223

📄 [www.siemens.com/automation/support-request](http://www.siemens.com/automation/support-request)