

**2-Channel Time Switch (Weekly Scheduler)  
REG 371**
**5WG1 371-5 EY01**

## Product and Applications Description



The 2-channel time switch REG 371 (weekly scheduler) with integrated bus coupling unit is a DIN rail mounted device for mounting in distribution boards. The connection to EIB is made via a bus connector.

The time switch offers: 36 schedules, which may be assigned to one, several or all weekdays (free block formation). Additionally, the REG 371 is already set ex factory with the current time and valid Middle European settings for daylight savings time switchover (summer / winter time). If another or no switchover is desired this can be set as described in the operation manual.

- Programmed schedules are saved for up to 10 years in case the bus voltage fails and the back-up battery runs low
- automatic program review
- 99 days holiday program, programmable 99 days in advance
- switching pre-select
- permanent ON/OFF
- Lithium battery backup, approx. 6 years

On each channel switching, priority and dimming or value messages can be transmitted at pre-set times.

## Application programs

### 11 S2 Switching, Value, Scene 221D01

- Switching telegram (1Bit)
- Positive drive telegram (2Bit)
- Dimming or value telegram (8Bit)
- Cyclical sending selectable
- A scene with up to 4 different telegram types can be pre-set for each channel

## Application examples

- Ideally suited for residential applications and smaller EIB projects
- Up to four telegrams may be sent to the bus when one channel schedule switches (e.g. at the end of a work day: switch off main lighting, close shutters, reduce room temperature, lock perimeter doors)

## Connection example

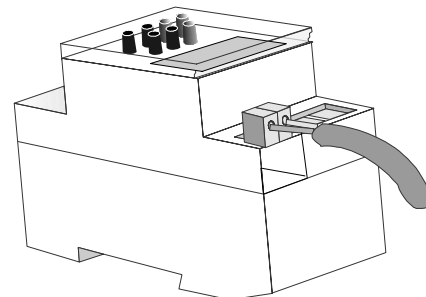

**2-Channel Time Switch (Weekly Scheduler)  
REG 371**

5WG1 371-5 EY01

### Technical Specifications

#### Power supply

Via bus line

#### Power consumption

6 mA

#### Functional specifications

- 2 channels
- memory locations: 36
- Automatic program: daily and weekly schedules
- Exception program: Holiday mode overriding the automatic program of both channels for up to 99 days with a preselection period of 0 to 99 days
- Manual control possibilities:
  - temporary manual switching
  - permanent manual switching
- shortest switching interval: 1 minute
- switching accuracy: 1 second
- block formation: free block formation of weekdays
- Summer / Winter adjustment: automatic
- Time basis: quartz
- Time accuracy: < 1sec./day at 20 °C
- Power reserve: > 6 years with indication during full operation (at 20°C)

#### Control elements

- 1 learning button:
  - for switching between normal operating mode and addressing mode
- 7 soft tip buttons:
  - for setting day of week, hour, minute, time, programm entry and 2 manual overrides

#### Display elements

- 1 red LED: for monitoring bus voltage and displaying mode selected with learning button
- LC Display: for display of time, day of week, day light savings mode, holiday program mode, switching status and manual control mode

#### Connections

- Bus line: screwless bus connection block  
0,6 ... 0,8 mm Ø single core

#### Physical specifications

- Polymer casing
- Dimensions: DIN rail mounted device  
110 x 72 x 54 mm (H x W x D), width 2 SU
- Weight: ca. 120 g
- Fire load: ca. 4100 KJ ± 10 %
- installation: rapid mounting on DIN EN 50022-35 x 7,5 rail

#### Electrical safety

- Fouling class (according to IEC 60664-1): 2
- Protection (according to DIN EN 60 529): IP 20
- Overvoltage class (nach IEC 60664-1): III
- Bus: safety extra low voltage SELV DC 24 V
- Device complies with: EN 50 090-2-2 and EN 60730-1

#### Reliability

Failure rate: 887 fit at 40°C

#### Electromagnetic compatibility

Complies with EN 50081-1, EN 50082-1 and EN 50090-2-2

#### Environmental specifications

- Climatic conditions: EN 50090-2-2
- Ambient temperature operating: - 5 ... + 45 °C
- Ambient temperature non-operating: - 25 ... + 70 °C
- rel. humidity (non-condensing): 5 % ... 93 %

#### Certification

EIB certified

#### CE norm

Complies with the EMC regulations (residential and functional buildings), and low voltage regulations

#### Dimension Diagram

Dimensions in mm

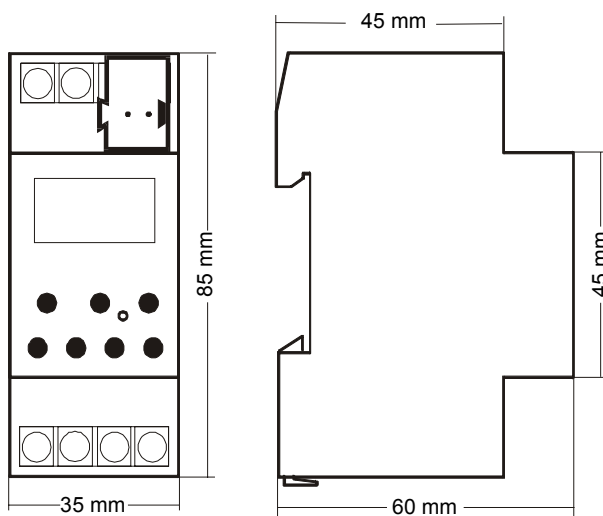

b = 2 SU  
1 Standard Unit (SU) = 17,5 mm

**2-Channel Time Switch (Weekly Scheduler)  
REG 371**

5WG1 371-5 EY01

### Installation Instructions

- Despite elaborate safety precautions exceptionally strong electromagnetic fields may cause interference with the microprocessor controlled 2-channel time switch. We therefore recommend that you observe the following points before installation:
  - Suppress interference of inductive loads by means of an RC filter.
  - Use a separate line for the mains voltage supply.
  - Do not install device in close proximity of sources of interference, e.g. transformers, contactors, PCs and TV sets.
  - If interference occurs we recommend that you carry out a RESET (chapter 4.7 of Operating Instructions) before putting the device back into operation.
  - The 2-channel time switch is provided with a Lithium battery. Please dispose of this battery ecologically friendly.



### WARNING

- The device may be placed into distribution boards (230/400 V) together with appropriate VDE-devices.
- The device must be mounted and commissioned by an authorised electrician.
- Free DIN rail areas with stuck-in data rail must be covered with covers, order no. 5WG1 192-8AA01.
- The prevailing safety and installation rules must be heeded.
- The device must not be opened. A device suspected faulty should be returned to the local Siemens office.

### Mounting and Wiring

#### General description

The N-system DIN rail device (2 SU) can be installed in N-system distribution boards and any other location or enclosure with DIN EN 50022-35 x 7,5 rails. The connection to the bus line is established through a front mounted bus connector block.

#### Mounting the device on a DIN rail (Figure 1)

- Slide the device (B1) onto the DIN rail (B2) and
- swivel the device (B1) back onto the DIN rail until the slide clicks into place audibly.

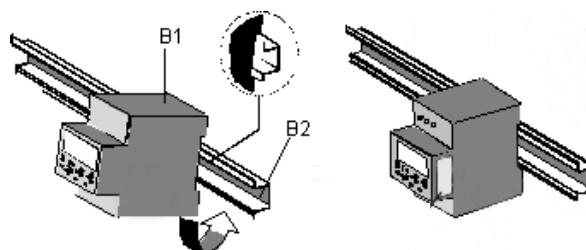

Figure 1: Mounting of DIN rail device

#### Dismounting the device from the DIN rail (Figure 2)

- Press down the slide (C3) with a screw driver and secure the slide in place by gently pressing it down and
- swivel the device (C1) from the DIN rail (C2) to the front.

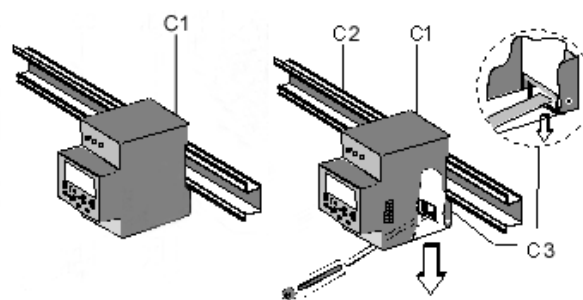

Figure 2: Dismounting of DIN rail device

### Operator Elements

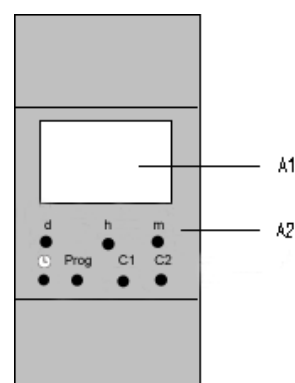

Figure 3: Location of display and operator elements

A1 LC Display

A2 Operation buttons of 2-channel time switch

*instabus EIB*

**Technical Product Information**

April 2002

**2-Channel Time Switch (Weekly Scheduler)  
REG 371**

**5WG1 371-5 EY01**

**Raum für Notizen**