

N 501 Combi sunblind actuator
4x Sunblind AC 230 V, 6 A, 8x Input AC/DC 12-230V

5WG1 501-1AB01

Product and functional description



The combination sunblind actuator N 501 is a device for DIN-rail mounting with N-system dimensions, 8 inputs for AC/DC 12-230V and 4 channels (= 8 relay contact outputs) for 230V AC, 6A (with resistive load) for the control of 1 sunblind drive each. 8 red LED on the top side of the device indicate the current switching state of the inputs. The power supply of the electronics is carried out via an integrated power supply unit for AC 230V. The device is to be used for sun protection control in the as-delivered state, even without a bus line connected and without prior configuration with the Engineering Tool Software (ETS). If connected to the KNX bus the device can be configured with the ETS3.

In the as-delivered state (stand-alone mode), all inputs act directly on the outputs, i.e. a pushbutton on input "a" deactivates (moves up) the sun protection on channel "A", a pushbutton on input "b" activates (moves down) the sun protection on channel "A", etc.. If a sunblind is to be operated from several points, then a number of pushbuttons can be connected in parallel to the corresponding inputs. If the sun protection is designed as Venetian blind, then a "long" operation of a pushbutton starts a travel of the blind into the corresponding end position. A "short" operation of a pushbutton stops a blind's travel or leads to open or close the slats by 1 step if the blind is stationary. Each output can be switched on and off in "Direct mode" as long as the corresponding pushbutton on the top side of the device (see figure 1) will be pressed. To do this, first the "Direct mode" has to be switched on by pressing the "Direct mode" button (yellow LED for direct mode indication comes on) and then the pushbutton assigned to the output has to be pressed. If, after direct switching of an output, direct mode is not ended by another press of the "Direct mode" pushbutton, then this is done automatically 15 minutes after the final press of one of the pushbuttons on the top side of the N 501.

Application program

The combi sunblind actuator N 501 requires the application program "25 A4 8x In / 4x Shutter 981701" which can be configured with the ETS up from version ETS3.0f.

If the N 501 is connected to the KNX bus line, the behavior of each input and each sunblind channel can be set with the ETS. In this case a sunblind channel of the N 501 can be controlled by pushbuttons directly connected to the inputs of the N 501 as well as by pushbuttons with bus interface connected to the bus. And a pair of pushbuttons connected to inputs of the N 501 can control the corresponding sunblind channel of the N 501 as well as channels of other sunblind actuators connected via the bus.

Depending on the configuration with the ETS inputs and outputs of the N 501 can also be operated independently of each other (decoupled). Each input may be configured and used like an input of a binary input device N 263/E01 and each sunblind channel may be configured and used like a channel of the sunblind actuator N 523/11.

Connection example

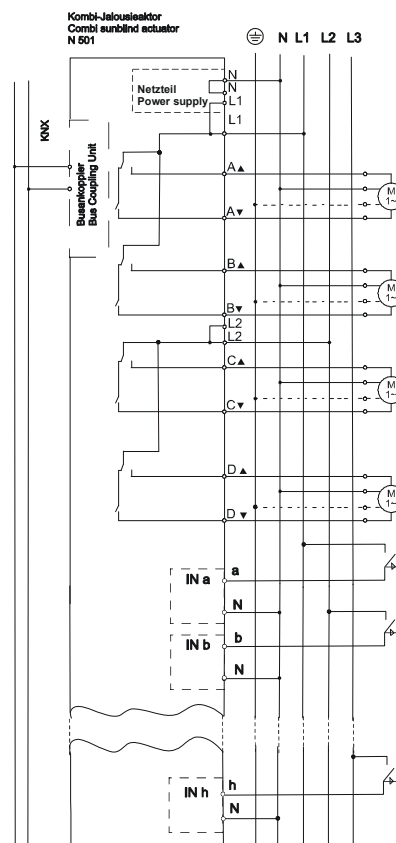

N 501 Combi sunblind actuator
4x Sunblind AC 230 V, 6 A, 8x Input AC/DC 12-230V
5WG1 501-1AB01**Installation notes**

- The device can be used for permanent installation in dry interior rooms and for insertion in control cabinets or small distribution boards.

**DANGER**

- The device must only be installed and commissioned by an authorized professional electrician.
- When looping through the L and N conductors, it should be noted that the maximum terminal current of 10 A, which is limited by the permitted printed conductor load, may not be exceeded!
- When connecting the device, care should be taken that the device can be isolated from the mains.
- The device must not be opened.
- When planning and installing electrical equipment the relevant guidelines, regulations and standards of the respective country are to be considered.

Technical data**Power supply**

- Bus voltage: supplied via the bus line
- Bus current: 5 mA (only half a standard bus load!)
- Electronics:
 - Integrated power supply unit for 230V AC, +10% / -15 %, 50/60 Hz
 - Power supply connection: 2-pole (made via the N and L1 terminals in the lower terminal block)
 - Power consumption: min. 1.1 W, max. 4.0 W

Inputs

- 8 inputs a...h (with basic isolation 250V towards each other and increased isolation towards KNX EIB)
- Input voltage: 12 ... 230V AC/DC
- ($V_{in} = 0...2V$: = voltage not present = log. 0;
 $V_{in} \geq 9V$: = voltage present = log. 1)
- Note: With DC, the negative pole is to be connected in each case to the terminal marked with "N".
- Input current:
 - at max. 253V AC: typically 1.5 mA (RMS)
 - at max. 253V DC: typically 3.0 mA
- Input signal delay:
 - with input signal edge rising:
 - max. 60 ms with DC, max. 100 ms with AC
 - with input signal edge falling:
 - max. 140 ms with DC, max. 100 ms with AC
- Input signal switch-on time:
 - min. 60 ms with DC, min. 100 ms with AC
- Input signal switch-off time:
 - min. 140 ms with DC, min. 100 ms with AC
- Input function: configurable
- max. length of connection leads: 100 m

Outputs

- 4 sunblind channels, each with 2 relay contact outputs electrically locked against each other,
- two channels switch the same L-conductor,
- per relay contact:
 - rated voltage: AC 230 V, 50/60 Hz,
 - rated current: 6 A (resistive load),
 - switching cycles: >25,000 at $\cos \varphi = 1$ and $I = 6$ A

Operating elements

- 1 commissioning pushbutton: for toggling between normal / addressing mode
- 1 pushbutton: for toggling between bus / direct mode
- 8 push buttons: for switching the corresponding sunblind output ON for the time being pressed

Display elements

- 1 red LED: for checking the bus voltage and for displaying normal mode / addressing mode
- 1 green LED: for displaying the 230V operating voltage
- 1 yellow LED: for displaying direct mode / bus mode
- 8 red LED: for status indication of the inputs a...h

Connections

- Power supply connection, inputs and outputs:
 - Plug-in terminals, insulation strip length 9...10 mm
- The following lead cross-sections are permitted:
 - 0.5 ... 2.5 mm² single-core
 - 0.5 ... 1.5 mm² finely stranded, with end sleeve
 - 1.5 mm² finely stranded, untreated (max. ampacity then 6 A!)
- Each phase conductor connected to the N 501 is to be fused with a miniature circuit-breaker of characteristic B or C for a max. rated current of 10A!
- Bus line:
 - Pressure contacts on data rail
 - Screw-less bus terminal, 0.6 ... 0.8 mm Ø, single-core, insulation strip length 5 mm

Mechanical data

- Housing: plastic
- Dimensions: device for DIN-rail mounting with N-system dimensions, width 8 module units (1 module unit = 18 mm)
- Weight: approx. 425 g
- Fire load: approx. 6150 kJ
- Installation: Snap-on mounting on DIN rail EN 60715-TH35-7.50

Electrical safety

- Degree of pollution (according to IEC 60664-1): 2
- Protection type (according to EN 60529): IP 20
- Overvoltage category (according to IEC 60664-1): III
- Bus: safety extra-low voltage SELV DC 24 V
- Device complies with: EN 50428

N 501 Combi sunblind actuator
4x Sunblind AC 230 V, 6 A, 8x Input AC/DC 12-230V
5WG1 501-1AB01**EMC requirements**

- complies with EN 50428

Environmental conditions

- Climatic withstand capability: EN 50090-2-2
- Ambient operating temperature: - 5 ... + 45 °C
- Storage temperature: - 25 ... + 70 °C
- Relative humidity (not condensing): 5 % to 93 %

Reliability

- Failure rate: 1435 fit at 40°C

Markings

- KNX EIB

CE mark

- In accordance with the EMC guideline (residential and functional buildings), low voltage guideline

Position and function of the display and operating elements

Figure 1: Position of the display and operating elements

- A1 Pushbutton for switching between normal mode and addressing mode for transferring the physical address.
- A2 LED (red) for indicating normal mode (LED Off) or addressing mode (LED On); it goes out automatically after transferring the physical address
- A3 Plug for bus connection terminal
- A4 LED (red) for status indication of inputs a, c, e, g
- A5 LED (red) for status indication of inputs b, d, f, h
- A6 Terminals for inputs a to h
- A7 N (neutral conductor) terminals
- A8 L1 (phase conductor) terminals (for powering the electronics and the sunblind channels A and B)
- A9 Terminals for sunblind up/down (channels A and B)
- A10 L2 (phase conductor) terminals (for powering the sunblind channels C and D)
- A11 Terminals for sunblind up/down (channels C and D)
- A12 Pushbuttons for direct switching of channels A to D
- A13 Pushbutton to switch direct mode on/off

A14 LED (yellow) to indicate "Direct mode = ON"

A15 LED (green) to indicate operating voltage

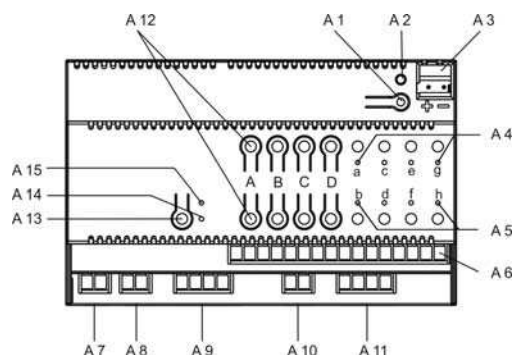
In the as-delivered state, without the bus line connected (stand-alone mode), the travel times from one end position to the other are set to 120 seconds and the on-time for moving a slat by 1 step to 0.2 seconds. Pressing a pushbutton at an input for more than 0.5 seconds is considered as "long" operation. You can change these parameters for stand-alone mode with the ETS if need be.

If the combination sunblind actuator N 501 is connected to the bus line, then not only the parameters for "Stand-alone Mode" can be changed with the ETS. The sunblind channels are then freely configurable and can be controlled via the bus. You can also then adjust whether the inputs are to act directly on the corresponding outputs or whether one of the possible input functions is to be assigned to the inputs (e.g. to report the status of a window switch).

Installation and wiringGeneral description

The DIN rail mounted device in N-system dimensions (width 8 module units) can be inserted in N-type distribution boards, surface- or flush-mounted and wherever DIN rails according to EN 60715-TH35-7.5 are present. The connection with the bus line is either carried out via the bus terminal or via the contact system to the data rail.

Installing the DIN rail mounted device (Figure 2)

- Suspend the DIN rail mounted device (B 1) on the DIN rail (B2) and
- Rotate the DIN rail mounted device (B1) backwards until the slide switch audibly clicks into position.

Dismantling the DIN rail mounted device (Figure 2)

- Press the slide switch (C3) downwards with a screwdriver and
- Remove the DIN rail mounted device (C1) from the DIN rail (C2) with a swivel action.

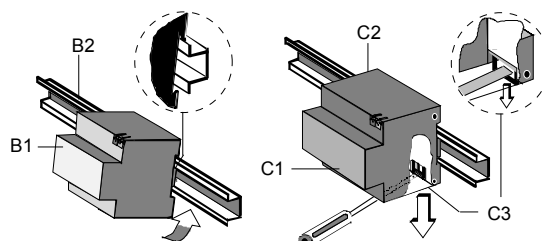

Figure 2: Installing / dismantling the device

Removing the bus terminal (Figure 3)

- The bus terminal is located on the top of the device (D1).

N 501 Combi sunblind actuator
4x Sunblind AC 230 V, 6 A, 8x Input AC/DC 12-230V

5WG1 501-1AB01

- The bus terminal (D2) consists of two sections (D2.1, D2.2) each with four terminal contacts. Care should be taken not to damage the two test sockets (D2.3) either by accidentally trying to put in the bus cable or with the screwdriver (when trying to remove the bus terminal).
- Carefully insert the screwdriver into bus terminal (D2) and shift it upwards out of the device (D1).

Note: Care should be taken as there is a risk of shorting the device!

Attaching the bus terminal (Figure 3)

- Place the bus terminal in the guide slot and press the bus terminal (D2) backwards until it reaches the stop.

Connecting the bus cable (Figure 3)

- The bus terminal (D2) is suitable for single-core conductors with 0.6... 0.8 mm Ø.
- Strip approx. 5 mm of insulation from the conductor (D2.4), plug in the terminal (D2) (red = +, black = -).

Disconnecting the bus cable (Figure 3)

- Remove the bus terminal (D2) and the conductor (D2.4) out of the bus cable by rotating it backwards and forwards.

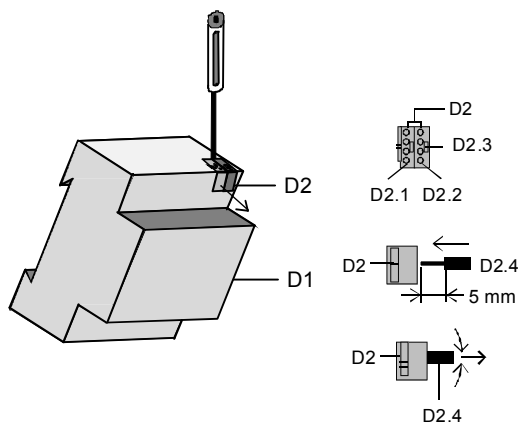

Figure 3: Attaching / removing the bus terminal

Connecting mains voltage, load circuits and inputs

- The connections are designed with plug-in technology.
- Strip approx. 9...10 mm of insulation from the conductors and slide them in the respective terminal.

Mounting the insulating cap

If the device is to be mounted on a DIN rail without a data rail, then the contact system must be covered using the supplied insulating cap.

Removing the locating clamp (Figure 4)

- The locating clamp (E3) encloses the contact system (E2) on the rear of the device (E1).

- Insert the screwdriver between the DIN rail mounted device (E1) and the locating clamp (E3) and remove the clamp.

Clipping on the insulating cap (Figure 4)

- Place the insulating cap (E4) on the contact system and press so that it snaps into place.

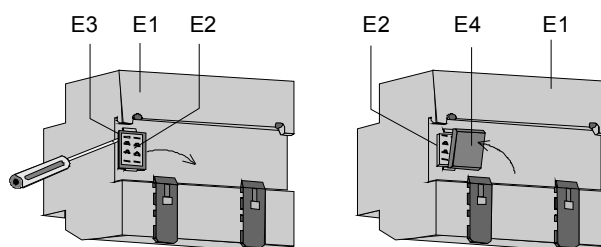
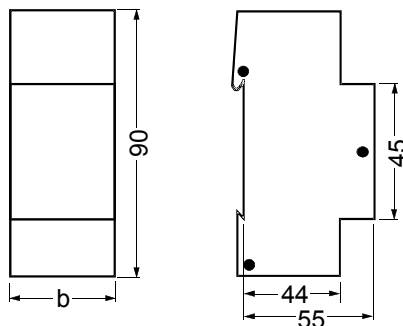

Figure 4: Covering the contact system

Note: Unoccupied sections of a DIN rail with data rail inserted must be protected with the cover 5WG1 192-8AA01.

Dimension drawing

Dimensions in mm



b = 8 module units 1 module unit (MU) = 18 mm

General notes

- Any faulty device should be returned to the local Siemens office.
- If you have further questions concerning the product, please contact our Technical Support:
 ☎ +49 (0) 180 50 50-222 (0,14€/min. from the German landline network, deviating mobile communications prices are possible)
 📠 +49 (0) 180 50 50-223
 E-Mail: support.automation@siemens.com
 Internet: www.siemens.com/automation/service&support