

Shutter Switch N 521
2 x 230 V AC / 6 A

5WG1 521-1AB01

Product and Applications Description



The shutter switch N 521 is a N-system DIN-rail mounted device. Via its volt free contacts it can control two separate blinds actuators to raise and lower blinds and to gradually adjust the louvres. Two channels (A and B) are available for two actuators each allowing control of up to four blind actuators. The actuator control outputs are connected quasi-parallel in pairs and locked via internal relay contacts to avoid mutual electrical interference when connecting two blind actuators. Otherwise, when one of the two blinds has reached an extreme position while the other is still moving, the windings of the inactive blinds actuator would be fed power via the capacitor of the actuator still running, moving it from the extreme position automatically.

The volt free contacts (two relays) can be assigned various tasks depending on the application program used, i.e. the shutter switch N 521 consists of the device (hardware) and its application programs (software) for controlling venetian blinds.

In the ETS (EIB Tool Software) the application program is selected, its parameters and addresses are assigned appropriately, and downloaded to the shutter switch N 521.

Application Programs

11 A2 Shutter 520206

- 2 blinds/sliding shutter control with safety mode
- safety position (up or down) if in bus voltage failure can be set in the parameter list
- may be used as 2 standard binary output with two mutually independent change-over contacts



WARNING

When using the shutter switch N 521 for controlling blinds actuators the instructions below must be followed (failure to do so may result in the contacts welding):

- Do not use older application programs (e.g. 11 A2 Shutter 520203) anymore with the shutter switch N 521, use 11 A2 Shutter 520205 instead.
- The factor and base values of the parameter "Reverse delay" must be combined to establish a time period as given by the blinds manufacturer (usually > 500 ms).
- The parameter "on bus voltage failure" should be set to "maintain actual state" or "stop".

Example of Operation

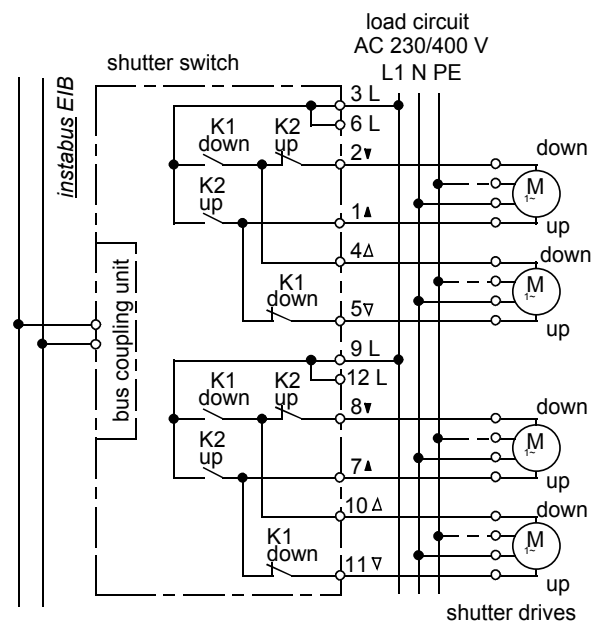

Shutter Switch N 521
2 x 230 V AC / 6 A

5WG1 521-1AB01

Installation Instructions

- The device may be used for permanent interior installations in dry locations within distribution boards.



WARNING

- The device may be built into distribution boards (230/400V) together with appropriate VDE-devices and must be mounted and commissioned by an authorised electrician.
- A safety disconnection of the device must be possible.
- Free DIN rail areas must be covered with covers, order no. 5WG1 192-8AA01.
- The prevailing safety rules must be heeded!
- The device must not be opened. A device suspected faulty should be returned to the local Siemens office.

Technical Specifications

Power supply

via bus cable

Outputs

- number: 2 output channels (volt free contacts)
- rated voltage: AC 230 V, 47 ... 63 Hz
- rated current: 6 A resistive load
- switching current at AC 230 V:
 - 0,01 ... 6 A resistive load
 - tubular motors with auxiliary phase condenser $\leq 14 \mu\text{F}$, max. power 500 VA at 20000 load switching cycles (UP-DOWN-STOP) respectively max. 750 VA at 12000 load switching cycles
 - total maximum load at $\cos\phi = 0,4$; 750 VA
- switching current at DC 24 V:
 - 6 A resistive load,
 - 4 A inductive load ($L/R = 7 \text{ ms}$)
- switching characteristic: set in parameter list according to application program
- switching repetition intervals: min. 150 ms

Control elements

1 learning button:
for switching between normal operating mode and addressing mode

Display elements

1 red LED:
for monitoring bus voltage and displaying mode, selected with the learning button

Connections

- load circuit, physical:
 - strip insulation for 9 ... 10 mm
 - permissible conductor types/cross sections:
 - 0,5 ... 2,5 mm² single core or flexible conductor, 8 mm ultrasonically compacted
 - 0,5 ... 2,5 mm² flexible conductor with terminal pin, crimped on gas tight
 - 0,5 ... 1,5 mm² flexible conductor with connector sleeve
 - 1,0 and 1,5 mm² plain flexible conductor
- load circuit, electrical:
 - plain flexible conductor, min. 1 mm²: current carrying capacity max. 6 A
 - all other conductors, min. 1,5 mm²: current carrying capacity max. 10 A
 - The load circuits must be protected with a 10 A miniature circuit breaker A or B characteristic.



WARNING

When looping through the L-conductor (connection blocks 3 and 6, 9 and 12), take care that the maximum connection current of 10 A (as governed by the maximum permissible printed conductor load) is not exceeded!

- bus line, pressure contacts on data rail

Physical specifications

- housing: plastic
- N-system DIN-rail mounted device, width: 3 SUs (1 SU = 18 mm)
- weight: approx. 225 g
- fire load: approx. 3600 kJ $\pm 10 \%$
- installation: rapid mounting on DIN EN 50022-35 x 7,5 rail

Electrical safety

- fouling class (according to IEC 664-1): 2
- protection (according to EN 60529): IP 20
- overvoltage class (according to IEC 664-1): III
- bus: safety extra low voltage SELV DC 24 V
- relay with μ -contact
- the device complies with EN 50090-2-2 and EN 60669-2-1

Reliability

rate of failure: 522 fit at 40 °C

Electromagnetic compatibility

complies with
EN 50081-1, EN 50082-2 and EN 50090-2-2

Shutter Switch N 521
2 x 230 V AC / 6 A

5WG1 521-1AB01

Environmental specifications

- climatic conditions: EN 50090-2-2
- ambient temperature operating: - 5 ... + 45 °C
- ambient temperature non-op.: - 25 ... + 70 °C
- relative humidity (non-condensing): 5 % to 93 %

Certification

EIB certificate

CE norm

complies with the EMC regulations (residential and functional buildings), and low voltage regulations

Location and Function of the Display and Operator Elements

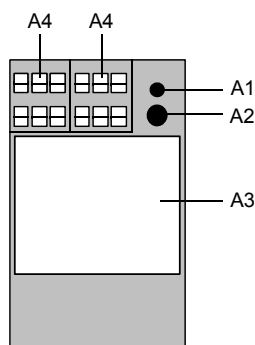

Figure 1: Location of the display and operator elements

- A1 LED for indicating normal operating mode (LED off) and addressing mode (LED on); upon receiving the physical address the device automatically returns to normal operating mode
- A2 Learning button for switching between normal operating mode and addressing mode for receiving the physical address
- A3 Type plate
- A4 Screwless plug-in terminals for connecting load circuits

Mounting and Wiring

General description

The N-system DIN-rail device (3 SUs) can be installed to N-system distribution boards, surface or flush mounted, or to any DIN-rail EN 50022-35 x 7,5 available that has a data rail installed.

The connection to the bus line is established by clicking the device onto the DIN-rail (with a data rail installed). Take care that the type plates of all devices on a DIN-rail can be read in the same direction, guaranteeing the devices are polarised correctly.

Mounting DIN-rail devices (Figure 2)

- Slide the device (B1) onto the DIN-rail (B2) and
- swivel back the device until the slide clicks into place audibly.

Dismounting DIN-rail devices (Figure 2)

- Remove all connected wires,
- press down the slide (C3) with a screw-driver and
- swivel the device (C1) from the DIN-rail (C2).

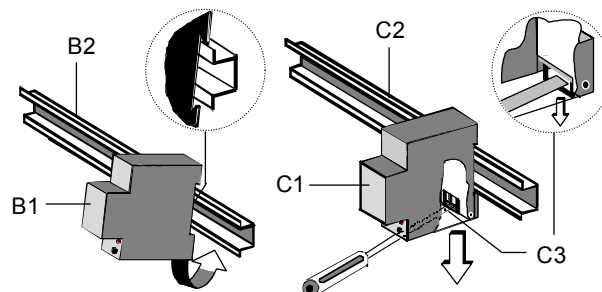

Figure 2: Mounting and dismounting a DIN-rail device

Connecting load circuits (Figure 3)

- The load circuits are connected via screwless plug-in terminals (D1).
- Remove approx. 9 to 10 mm of insulation from the wire (D1.1) and plug it into the terminal (D1).

Conductor cross sections:

- load circuit, physical:
 - strip insulation for 9 ... 10 mm
 - permissible conductor types/cross sections:
 - 0,5 ... 2,5 mm² single core or flexible conductor, 8 mm ultrasonically compacted
 - 0,5 ... 2,5 mm² flexible conductor with terminal pin, crimped on gas tight
 - 0,5 ... 1,5 mm² flexible conductor with connector sleeve
 - 1,0 and 1,5 mm² plain flexible conductor
- load circuit, electrical:
 - plain flexible conductor, min. 1 mm²: current carrying capacity max. 6 A
 - all other conductors, min. 1,5 mm²: current carrying capacity max. 10 A

Disconnect load circuits (Figure 3)

- Press the terminal lock (E1.2) with a screw-driver and
- remove the wire (E1.1) from the terminal (E1).

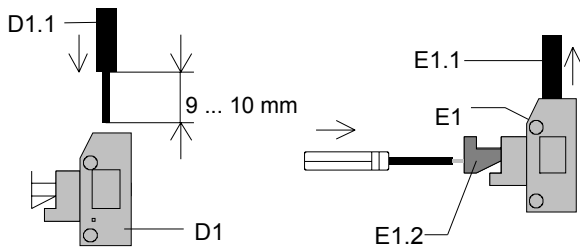
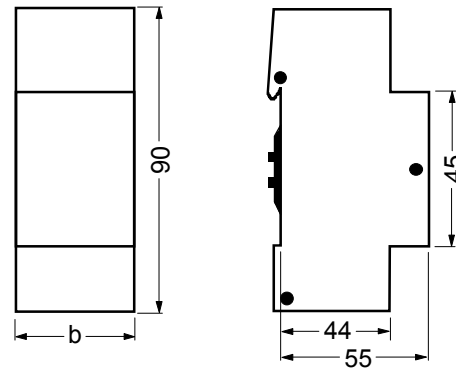

Figure 3: Connecting and disconnecting wires

Dimension Diagram

Dimensions in mm



b = 3 SU