

Bending beam load cell 0...5 kg up to 0...500 kg Model F3833

Applications

- Hopper scales
- Packing scales
- Gravimetric feeder
- Industrial weighing systems

Special features

- Measurement ranges 0...5 kg up to 0...500 kg
- Bending beam load cell with welded-on metal bellows
- Protection class IP68



Certificates



Description

Bending beam load cells are designed for static and dynamic measurement tasks. They determine the forces in a wide scope of applications.

These bending beam load cells are used in industrial weighing and laboratory as well as in the process industry.

The load cells of the F3833 series are made of stainless steel, which are particularly suitable for the application areas. The output signal is a mV/V signal.

Note

In order to avoid overloading, it is advantageous to connect the load cell electrically during installation and to monitor the measured value. The force to be measured must be applied concentrically and free of transverse force.

The load cells are to be mounted on a level surface.

Specifications in accordance with VDI/VDE/DKD 2638

Model series	Symbol	Unit	F3833												
Measurement range															
Nominal load	F_{nom}	kg	5	10	20	30	40	50	75	100	150	200	250	300	500
Accuracy and stability															
Relative linearity error	d_{lin}	$x\%F_{nom}$	±0.02												
Relative reversibility	v	$x\%F_{nom}$	±0.02												
Relative repeatability error in unchanged mounting position	b_{rg}	$x\%F_{nom}$	±0.02												
Relative deviation of zero signal	$d_{S,0}$	$x\%F_{nom}$	±2												
Relative creep, 30 at min.		$x\%F_{nom}$	±0.02												
Temperature effect on zero signal	TK_0	$\%/10\text{ }^\circ\text{C}$	< ±0.03												
Temperature effect on characteristic value	TK_C	$\%/10\text{ }^\circ\text{C}$	< ±0.03												
Mechanical characteristics															
Force limit	F_L	$x\%F_{nom}$	150												
Breaking force	F_B	$x\%F_{nom}$	200												
Material			Stainless steel												
Temperature ranges															
Rated temperature range	$B_{T,nom}$	$^\circ\text{C}$	-10...60												
Operating temperature range	$B_{T,G}$	$^\circ\text{C}$	-20...80												
Electrical characteristics															
Output signal (rated output)	C_{nom}	mV/V	2.0 ± 1 % (3.0 ± 1% optional)												
Input resistance	R_e	Ω	385 ± 10												
Output resistance	R_a	Ω	350 ± 5												
Insulation resistance	R_{is}	M Ω	± 5,000/DC 100 V												
Recommended excitation voltage		V	10												
Maximum excitation voltage		V	15												
Electrical connection			Cable \varnothing 5 x 3,000 mm												
General data															
Protection (acc. to EN/IEC 60529)			IP68												
Weight		kg	0.6												
Certificates			Nominal loads from 0...50 kg to 0...250 kg acc. OIML R60 – Edition 2000 (E) with accuracy class C3 certificated												

Dimensions in mm

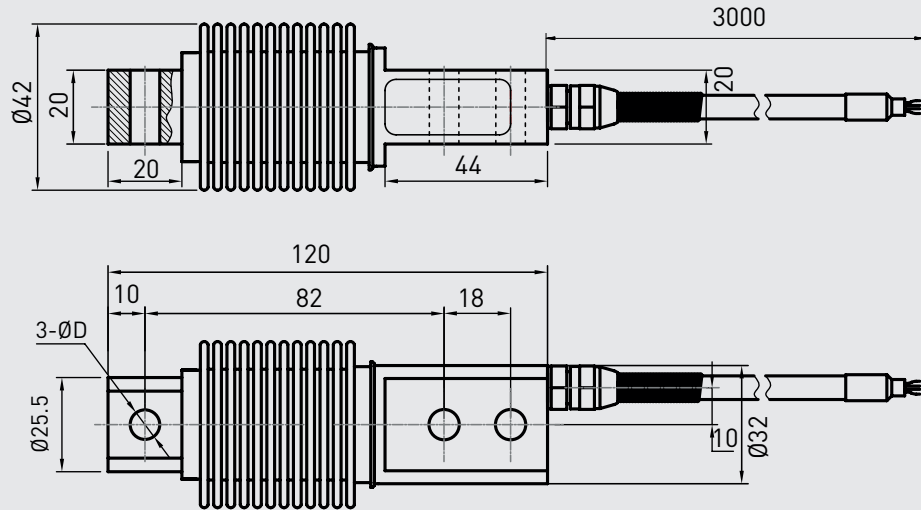

Nominal load in kg	Dimensions in mm
	D
5/10/20/30/40/50/75/100/ 150/200/250	8.2
300/500	10.2

Pin assignment

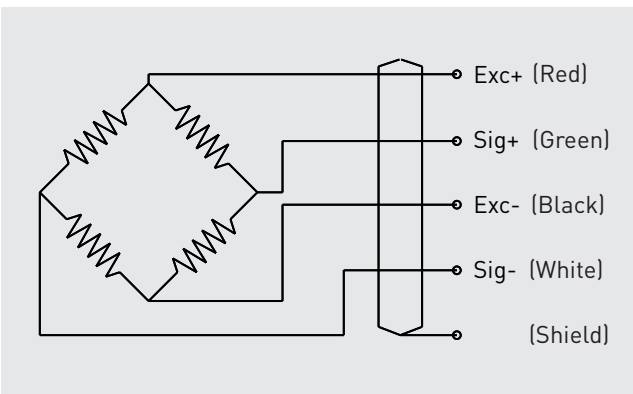

Electrical connection	
Excitation voltage (+)	Red
Excitation voltage (-)	Black
Signal (+)	Green
Signal (-)	White
Screen	Screen

© 09/2017 tecsis GmbH, all rights reserved.
The specifications given in this document represent the state of engineering at the time of publishing.
We reserve the right to make modifications to the specifications and materials.