

Ring force transducer for bold forces



Description

Miniature force transducers are specially designed to have small dimensions. Because of their compactness, these force transducers can be used in a wide range of industrial and laboratory applications. Small dimensions enable force transducers to be installed where the forces to be measured can be directed straight through the force transducer.

The field of application of this force transducer lies in innumerable applications where simple installation is a very important factor.

The force transducer is easy to use due to the simple way force is applied.

The force is applied vertical to force transducer axis.

Note

In order to avoid overloading, it is advantageous to connect the load cell electrically during installation and to monitor the measured value.

The force to be measured must be applied concentrically and free of transverse force.

The load cells are to be mounted on a level surface.

Features

- for compression force measurements
- simple force introduction
- compact small dimensions
- simple installation
- very low installation height
- Protection class IP 63
- Accuracy 0.5% of full scale value

Measuring ranges

- 50 N ... 100 kN

Applications

- Plant engineering
- Screw and pin assembly
- Cutting tools
- Cap and disk fastening
- Bearing forces
- Spot welding machines
- Measurement and inspection equipment
- Test benches and production lines

Model: F6211

Technical data

Model	F6211
Nominal load F_{nom} in N kN	50, 100, 200, 500 1, 2, 5, 10, 20, 50, 100
Accuracy	0.5% F_{nom}
Limit load	150% F_{nom}
Breaking load	>300% F_{nom}
Combined error	0,25% F_{nom}
Max. dynamic load	$\pm 70\%$ F_{nom} acc. to DIN 50100
Creep, 30 min. at F_{nom}	$\leq \pm 0.1\%$ F_{nom}
Nominal deflection	<0.1 mm
Nominal temperature range	-10 ... 50°C
Service temperature range	-30 ... 80°C
Storage temperature range	-50 ... 95°C
Reference temperature	23°C
Temperature effect -span -zero	< $\pm 0.2\%$ of F.S. / 10K < $\pm 0.2\%$ of F.S. / 10K
Protection type (acc. to EN 60529/IEC 529)	IP 63
Insulation resistance	> 2 G Ω
Analogue output - Output signal - Bridge resistance - Option - Excitation voltage - Electrical connection	0.8 ... 1.2 mV/V 350 Ω Cable integrated amplifier 0(4) ... 20 mA, 0 ... 10 V DC 2 ... 12 V (max. 15 V) 12 ... 28 V DC for cable integrated amplifier Cable 3 m
Material of measuring device	Stainless steel
Weight (kN) - 0,05 – 0,5 - 1 - 2 - 5 - 10 - 20 - 50 - 100	0,06 kg 0,08 kg 0,09 kg 0,10 kg 0,19 kg 0,72 kg

of F.S. = full scale value

Dimensions

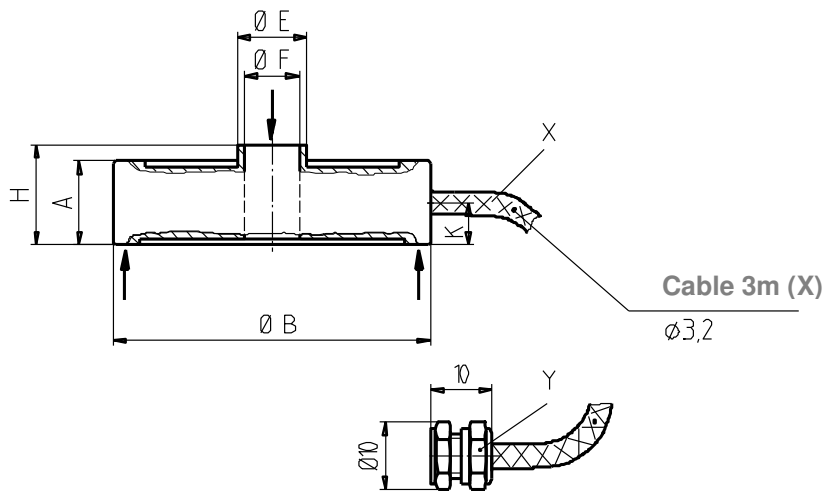

Nominal load	Cable-connection	Dimension in [mm]					
		$\varnothing B$	$\varnothing E$	$\varnothing F$	A	H	K
50 N	X	30	9,0	5,2	8	9,5	4,5
100 N	X	30	9,0	5,2	8	9,5	4,5
200 N	X	30	9,0	5,2	8	9,5	4,5
500 N	X	30	9,0	5,2	8	9,5	4,5
1 kN	X	38	13,5	7	9	10	4,0
2 kN	X	38	13,5	7	9	10	4,0
5 kN	X	38	13,5	7	9	10	4,0
10 kN	X	38	13,5	7	9	10	4,0
20 kN	Y	49	23	14	15	16	4,5
50 kN	Y	49	23	14	15	16	4,5
100 kN	Y	78	42	27	24	25	7,5

Electr. connection	
Vers. (-)	green
Vers. (+)	brown
Sign. (+)	yellow
Sign. (-)	white
Control	grey
Screen	Screen

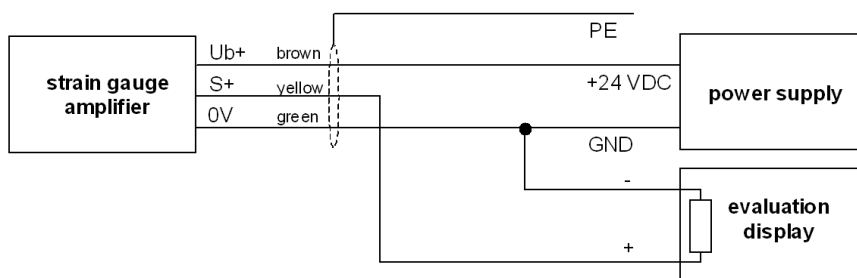

Pin assignment for cable integrated amplifier

Subject to technical alternations