

## Compression force transducer ultra compact

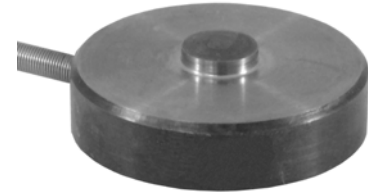

**Accuracy:** 0.25 % of F.S.  
**Output signals:** 2 mV/V; w-wire  
 4...20 mA; 3-wire

**Optional** for SIL3-applications  
 with a 2-channel PC control



### Description

The compression force is characterized especially by its small diameter and height. With its compact dimensions and robust design, this load cell, manufactured from stainless steel, can be used in a wide variety of stations, in test bays and laboratories.

The load cell is easy to handle and facilitates relatively simple installation. Its compact dimensions make it particularly suitable for use in highly constricted structures where pressure forces are to be measured.

### Note

In order to avoid overloading, it is advantageous to connect the load cell electrically during installation and to monitor the measured value.

The force to be measured must be applied concentrically and free of transverse force. The load cells are to be mounted on a level surface.

### SIL-3 (Option)

In cooperation with the TÜV Süddeutschland a special security electronics has been developed for theatre and stage applications. It fulfils security standard SIL 3 with a 2-channel PC control in connection.

### Features

- For compression forces
- Membrane design
- Ease of force input
- Compact and small dimensions
- Ease of assembly
- Very low installation height
- Protection class IP 67
- Combined error 0.25% of F.S.

### SIL-3 (Option)

- Security electronic
- SIL-3 approval with
- 2-channel PC control;
- accreditation:
- Certificate TÜV-Süd-No.  
Z-IS-ATA3-MAN 600219499  
acc. to EN 62061:2005

### Measuring ranges

- 0.25...225 kN

### Applications

- Plant engineering
- Machine tool construction
- Measurement and inspection equipment
- Precision engineering
- Fully automated production centres, etc.

### SIL-3 (Option)

For theatre and stage design:

- Above-stage machinery
- Below-stage machinery
- Point hoists
- Bar hoists

**Model: F1226**

## Technical data

Model	F1226	F12C6 SIL-3 (Option)
Nominal load $F_{nom}$	0.25...225 kN	
Accuracy	±0.25% of F.S.	±0.5% of F.S.
Limit load	150% $F_{nom}$	
Limit transverse force	>300% $F_{nom}$	
Hysteresis	±0.20% of F.S.	
Repeatability	±0.10% of F.S.	
Nominal temperature range	+15 to 70°C	+15 to +70°C
Service temperature range	- 54 to +121°C	- 20 to +80°C
Temperature effect		
- span	≤±0.18% reading / 10K	≤±0.2% reading / 10K
- zero	≤±0.09% of F.S./ 10K	≤±0.2% of F.S./ 10K
Protection type (acc. to EN 60 529/ IEC 529)	IP 67	
Noise emission		acc. to EN 61326
Noise immunity		acc. to EN 61326
Insulation resistance	> 5 x 10 <sup>9</sup> Ω	> 5 x 10 <sup>9</sup> Ω bzw. >5 GΩ / 50 V
Electrical protection		Reverse polarity, overvoltage and short circuit protection
Analogue output:		
Output signal	2 mV/V (± 2%)	4...16mA ; 3-wire signal swing 4mA ±0,2 mA, other on request
Bridge resistance	1000 Ω	
Excitation voltage	10...15 VDC	10...30 VDC for current output SIL3-Relais 24VDC (+50%/-20%), power consumption ~ 100 mW
Tolerance of span	±2% v. EW.	-
Electrical connection	4-wire (PUR) length: 1 m	4-wire (PUR) length: customer specific
Cable Amplifier (optional)	4...20 mA; 0...10V; 3-wire	
Certification		TÜV: Z-IS-ATA3-MAN 600219499 acc. to EN 62061:2005
Material of measuring device	Stainless steel (force transducer and amplifier housing)	

Of F.S.= of full scale value

**Dimensions with blind holes for mounting force transducer (standard version)**

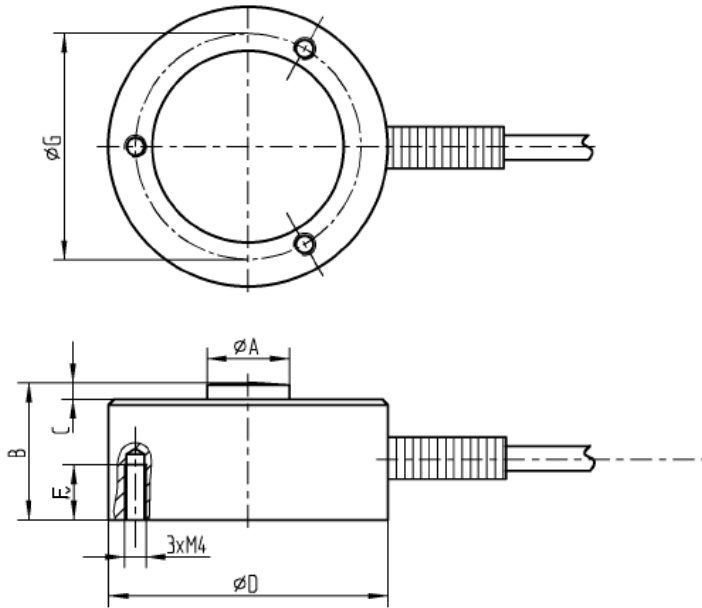

Type	Nominal load	D	A	B	C	E	F
Type 1	0.25...10 kN	31.8	8.1	9.9	1.8	25.4	6
Type 2	15...45 kN	38.1	10.9	16.0	2.0	31.8	10
Type 3	50...135 kN	50.8	15.2	25.4	3.0	41.3	10
Type 4	140...225 kN	76.2	19.8	38.1	4.6	60.3	10

All dimensions in [mm]

**optional:**

**Dimensions with through hole (without thread) to fasten the force transducer**

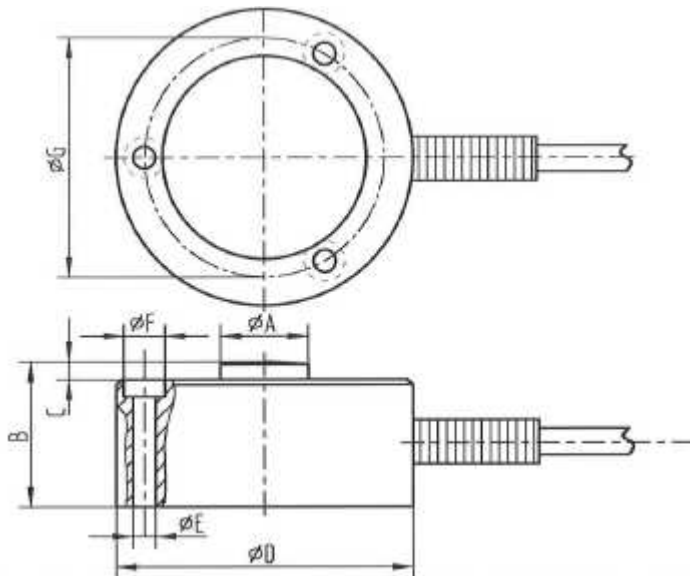

Type	Nominal load	D	A	B	C	E	F	G
Type 1	15...25 kN	38.1	10.9	16.0	2.0	3.2	5.5	31.8
Type 2	25...50 kN	50.8	15.2	25.4	3.0	3.9	7.1	41.3
Type 3	55...125 kN	76.2	19.8	38.1	4.6	3.9	7.1	60.3

All dimensions in [mm]

**Dimensions of optional cable amplifier, output signals 4...20 mA or 0...10V (with or without SIL-3) 3-wire.**

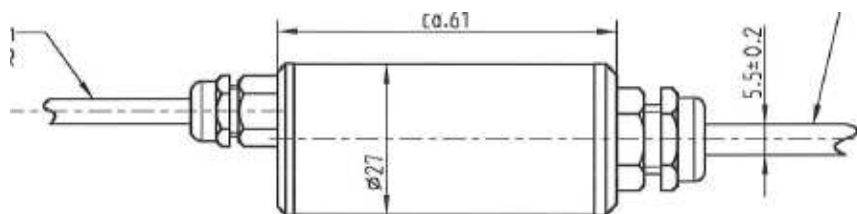

**Electrical connection without amplifier (output signal 2mV/V; 4-wire)**

Electrical connection	
Supply: UB+	red
Supply: 0V	black
Signal: S+	white
Signal: S-	green

**Analog output with cable amplifier (output signal 4...20mA or 0...10V) 3-wire**

Electrical connection	
Supply: UB+	brown
Supply: 0V	blue
Signal: S+	black
Signal: S-	blue
⊕	screen

**Analog output with cable amplifier (output signal 4...20mA or 0...10V) and with SIL-3 (optional) 3-wire**

Electrical connection	
Supply: UB+	brown
Supply: 0V	blue
Supply Relay: UR	white
Supply Relay: 0V	blue
Signal: S+	black
Signal: S-	blue
⊕	screen

## Brief description SIL-3

Amplifier-Electronics 4...20mA or 0...10V  
**for SIL-3 applications with 2-channel PC control**  
 (Certified by TÜV Süddeutschland, Germany)



Force Transducers, which are based on strain gauges, are working with four variable resistors (R1...R4) connected to a Wheatstone Bridge. Caused by deformation of the body the respective opposite resistors are lengthened or compressed in the same way. This results in an unbalanced bridge and a diagonal voltage  $U_0$ .

This well proven design has been amended by an additional resistor R7 in order to monitor the condition of the amplifier unit and signal path. This resistor is connected as a shunt to resistor R5 by a relay contact (a) as soon as an excitation voltage  $U_r$  appears at relay A.

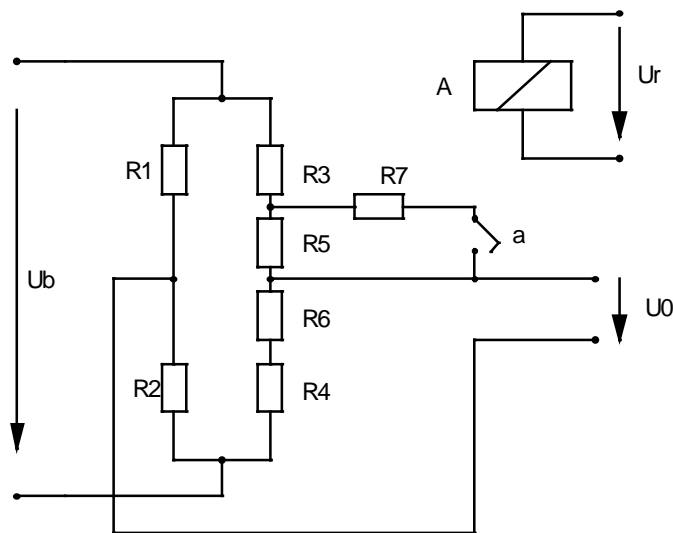
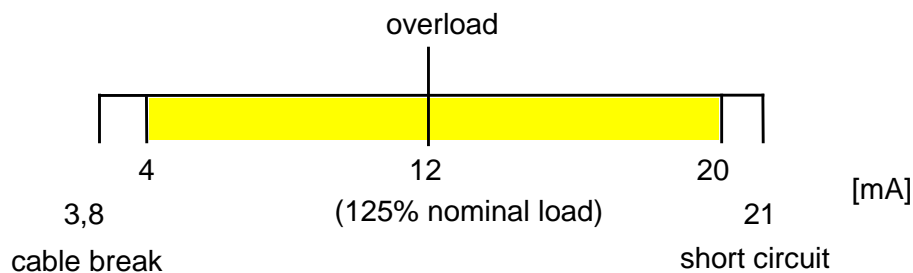

Fig.

The connection of resistor R7 will always result in a defined unbalancing of the zero point (diagonal voltage) of the Wheatstone Bridge.

An external independent control unit activates relay A which changes the output by a certain value. Because of security reasons the control unit has to be a 2-channel one. When the expected change of the output signal is detected it can be assumed that the whole signal path (Wheatstone Bridge – amplifier – output) works well. If it does not appear it can be concluded that there is a defect in the signal path.

The standard adjustment of force transducers with current output for overload control is e.g.:



With activating the check relay a fixed signal jump of 8 mA will exceed the overload limit in every working condition. The measurement's upper limit of 20 mA however will never be reached. This makes the checking of the signal jump possible.

Subject of technical changes