

Compression force transducer up to 100 kN

with electrical output



Description

Because of its small dimensions and solid design this load cell made of high grade stainless steel can be used in the laboratory and testing sector in the most diverse branches of industry.

This load cell is easy to handle and is relatively easy to install.

Due to its small dimensions it is predestined for installation more especially in structures where space is at a premium and pressure forces have to be measured.

Note

In order to avoid overloading, it is advantageous to connect the load cell electrically during installation and to monitor the measured value.

The force to be measured must be applied concentrically and free of transverse force.

The load cells are to be mounted on a level surface.

Features

- for compression force measurements
- simple force introduction
- compact small dimensions
- simple installation
- Protection class IP 65
- Accuracy 0.5% of full scale value

Measuring ranges

- 0,01 kN ... 100 kN

Applications

- plant engineering
- production lines
- Measurement and inspection equipment
- Special equipment and machinery construction

Specific information

- Limit load > 300% (option)
- Breaking load >800% (option)
- Calibration control 100% signal
- Sensitivity 1,00 mV/V

Model: F1213

Technical data

Model	F1213	Options
Nominal load F_{nom}	0,01, 0,02, 0,05, 0,1, 0,2, kN 0,5, 1, 2, 5, 10, 20, 50, 100 kN	Overload protec., 5-fold; ($\leq 0,2\text{kN}$) Overload protec., 3-fold; ($\geq 0,5\text{kN}$)
Limit load	$150\% F_{nom}$	$>300\% F_{nom}$
Breaking load	$>300\% F_{nom}$	$>800\% F_{nom}$
Combined error	$\leq \pm 0.25\%$ of F.S.	1.00 mV/V
Max. dynamic load	$\pm 70\% F_{nom}$ acc. to DIN 50100	
Creep, 30 min. at F_{nom}	$< \pm 0.1\%$ of F.S.	
Nominal deflection	< 0.3 mm	
Nominal temperature range	-10 bis +50°C	
Service temperature range	-30 bis +80°C	
Storage temperature range	-50 bis +95°C	
Reference temperature	23°C	
Temperature influence -span -zero	$\pm 0.2\%$ of F.S./ 10K $\pm 0.2\%$ of F.S./ 10K	
Protection type (acc. to EN 60 529/IEC 529)	IP 65	
Insulation resistance	> 2 G Ω	
Analogue output - Output signal - Bridge resistance - Option - Tolerance of span - Excitation voltage - Option - Electrical connection	0.8 ... 1.2 mV/V 350 Ω Cable integrated amplifier 0(4) ...20mA 0 ... 10 V DC $\leq \pm 0,5\%$ of F.S. 2 ... 12 V (< 100 N = 2 ... 6 V) max. 15 V (< 100 N = 8 V) 12 ... 28 V DC for cable integrated amplifier Cable 3 m / 4-wire, shielded	
Calibration control		
Sensitivity		1,00 mV/V
Material of measuring device	Stainless steel	
Weight (kN) - 0,01 – 0,02 - 0,05 – 0,5 - 1- 100	0,07 kg 0,08 kg 0,15 kg	

of F.S. = full scale value

Dimensions

with overload protection

without overload protection

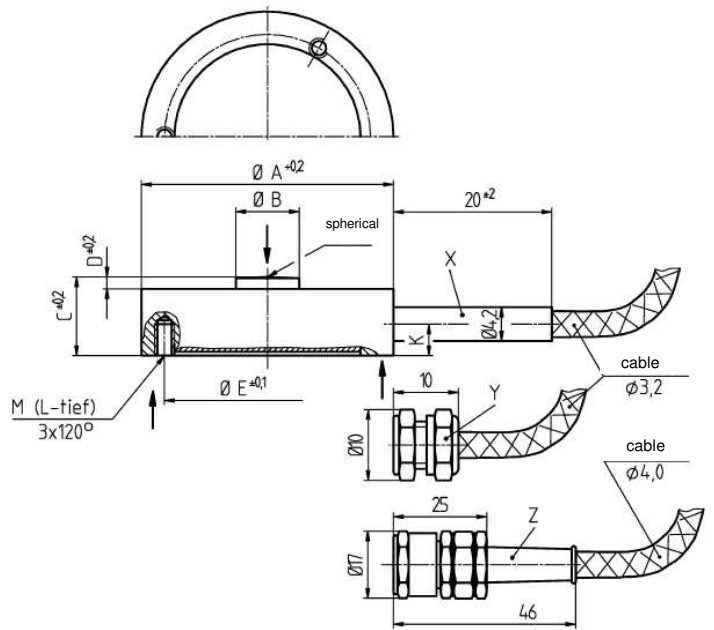
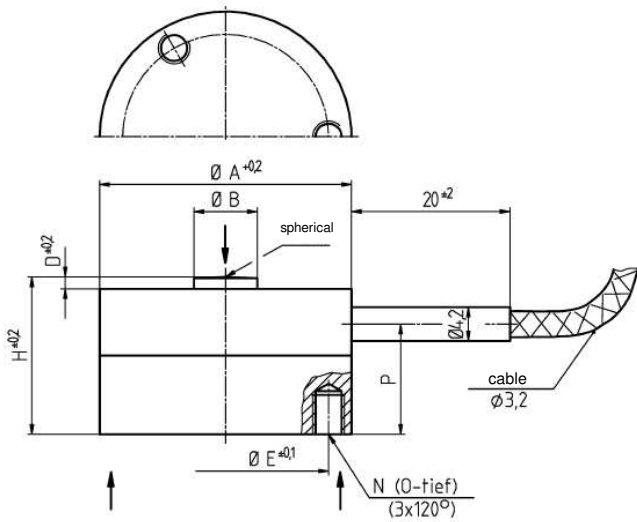

Measuring range [kN]	Dimensions in [mm]														
	ØA	ØB	C	D	ØE	H	L	M	N	O	P	K	X	Y	Z
0,01, 0.02, 0.05, 0.1, 0.2, 0.5, 1, 2, 5, 10	32	8	10	1.8	26	20	4	M2.5	M4	5	14	4	•	---	---
20	39	11	16	2.0	32	24	5	M3	M3	5	12.5	4.5	---	•	---
50	52	15	25	3.0	42	40	6	M4	M4	5	25	10	---	---	•
100	79	20	39	5.0	65	50	6	M5	M5	6	21	10	---	---	•

Elec. connection	
Vers. (-)	green
Vers. (+)	brown
Sign. (+)	yellow
Sign. (-)	white
Control	grey
Screen	Screen

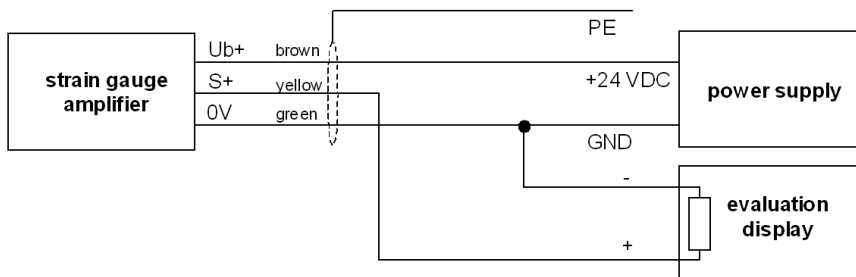

Pin assignment for cable integrated amplifier

Subject of technical changes