

## Test set for measuring of electrode forces

e.g. of welding guns



### Description

The test set can be used to check electrode force in spot-welding equipment. The test set consists of a force transducer and a display unit. To check the forces acting between the electrodes, the force transducer is held between the electrodes. The concave force transfer surfaces centre the force transducer. When the welding electrodes come together, the magnitude of the applied force can be read off on the display unit.

The force transducer is of shear force construction and therefore insensitive to transverse forces and torques. It has a measuring range of 0...10 kN. The output signal is connected to the handheld display unit via a cable. This display unit carries the voltage supply for the transducer. Alternatively, the supply can be taken from a PLC.

The proven tectsis thin-film sensors are implanted in this type of force transducer too. The sensor, which is welded in via laser, has all advantages of the conventional bonded foil strain gauges, but without having their substantial disadvantages (temperature drifts of the glue and creeping).

### Features

- Robust design
- Easy to handle
- Low total weight of 6 kg approx.
- Max./Min. value memory
- Illuminable large display
- Low measurement uncertainty
- Electrode diameters 14 ... 20 mm

### Measuring range

- 10 kN; 20 kN

### Areas of use

- Measurement of electrode force in spot welding apparatus

### Scope of delivery

Supplied in plastic case, handheld display unit, force transducer, charger, 2 metre signal cable, IR/RS232-Converter, manufacturer's test certificate

**Model: FSK01X001001**

## Technical data

<b>Model</b>	<b>FSK01</b>
Load range	10 kN; 20 kN
Accuracy	< 0.2%
Display unit	LCD-display, 5-digit, illuminated
Interface	Infrared, serial, for data transmission
Additional display functions	MIN, MAX, HOLD, AVG, TARA, LGT
Operating time	8 hours (per battery charging)
Service temperature range	-20°C ... +60°C
Degree of protection	Force transducer IP67, Display unit IP40
Weight	appr. 6 kg
Dimensions (B x H x D)	445 x 165 x 350 mm

## Calibration

Force transducer and display unit are calibrated together as a measuring chain. A repeat calibration is recommended every 12 months. This service can be performed quickly and reliably at tecsis' own workshops.

## Dimensioned drawing

### Force transducer

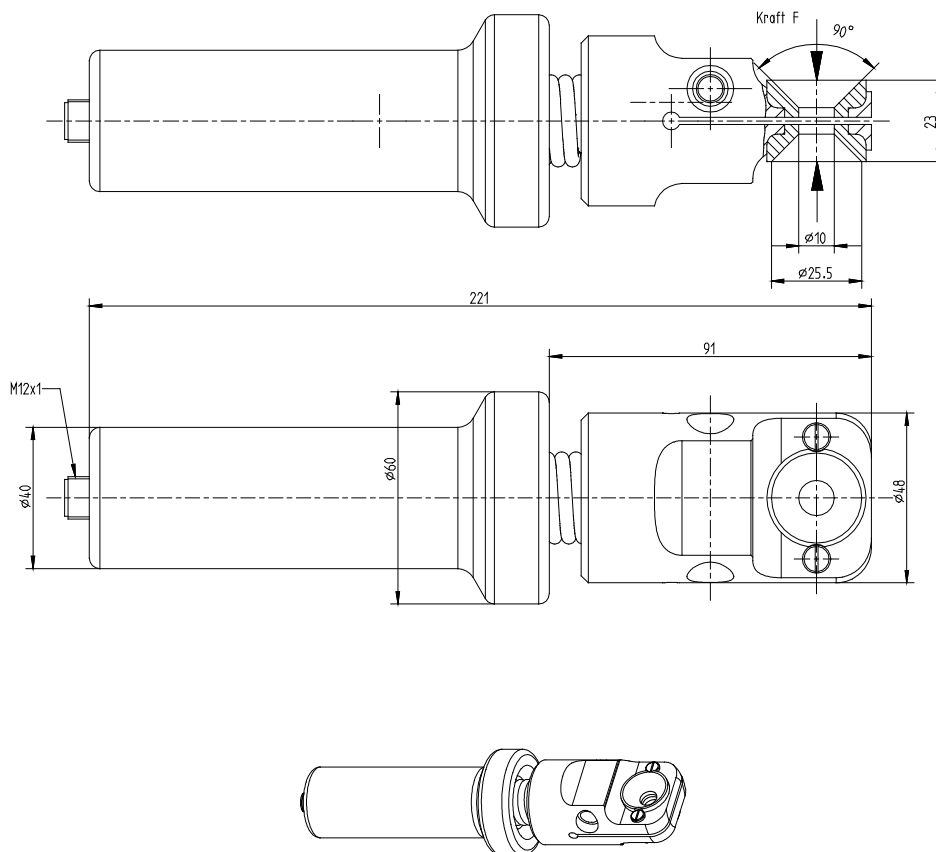

Subject to change without notice