

Clamp-on Sensor

with integrated amplifier



Description

The tecsis wire rope transducer is the first choice for retrofitting an overload safety system to hoists and cranes. Changes in the machine construction or a construction analysis are not necessary.

The task of the transducer is to survey the rope tension in an easy, robust and precisely way. The condition to use this sensor is a "dead end", where the rope is not in motion and fixed. The sensor is easily mounted to the rope with a clamp-on design in short time.

Operating this sensor in an overload protection system, the signal is monitored in a scalable load limiting electronic according to customer needs.

Features

- For overload protection on cranes, hoists and for tension measurement on ropes
- Ideal for retrofitting
- Stainless steel
- IP67
- Optional safety chain available
- Integrated amplifier
- Redundant output signal (optional)

Measuring ranges

- From 1t to 30t
(for rope diameter 8-44 mm)
- other measuring ranges on request

Applications

- Overload protection
- Tension measurement on ropes

Model: F9304

Technical data

Model	F9304	Option
Nominal load F_{nom}	1-30 t	
Rope diameter	8-44 mm	
Repeatability application	$<\pm 1.0\%$ of F.S.	
Limit load	$150\% F_{nom}$	
Breaking load	$> 300\% F_{nom}$	
Nominal temperature range	-20 ... +80°C	
Service temperature range	-40 ... +80°C	
Temperature effect - Span	$0,2\% F_{nom} / 10K$	
Temperature effect - Zero	$0,2\% F_{nom} / 10K$	
Isolation resistance	$>50G\Omega/50V$	
Analogue output		
- Output signal	4 ... 20 mA	2 x 4 ... 20 mA
- Excitation voltage	10 ... 30 VDC	others on request
Electrical connection	Plug M12x1	
Protection type (acc. to EN 60 529 / IEC 529)	IP67	
Material of measuring device	Stainless steel	
Accessories		Safety chain 1 m

Of F.S. = of full scale

Dimensions

Version 1 (<25 mm rope diameter)

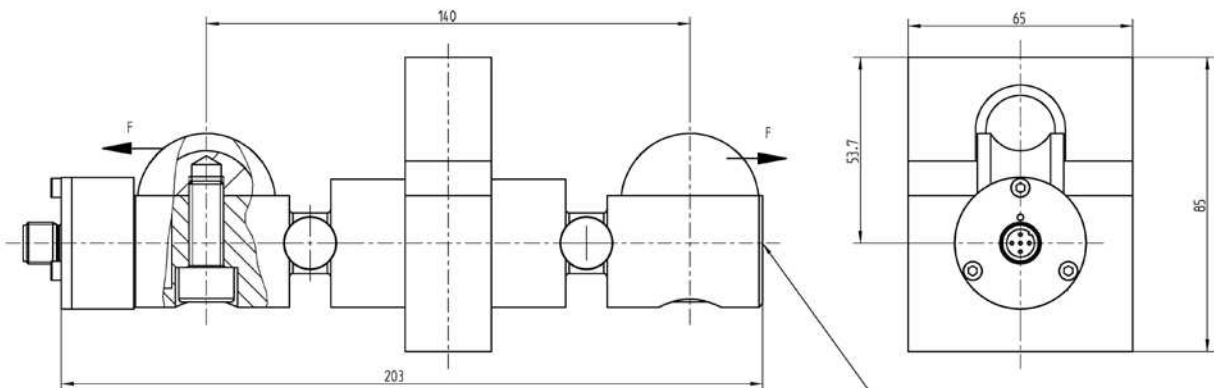

Version 2 (<25 mm rope diameter)

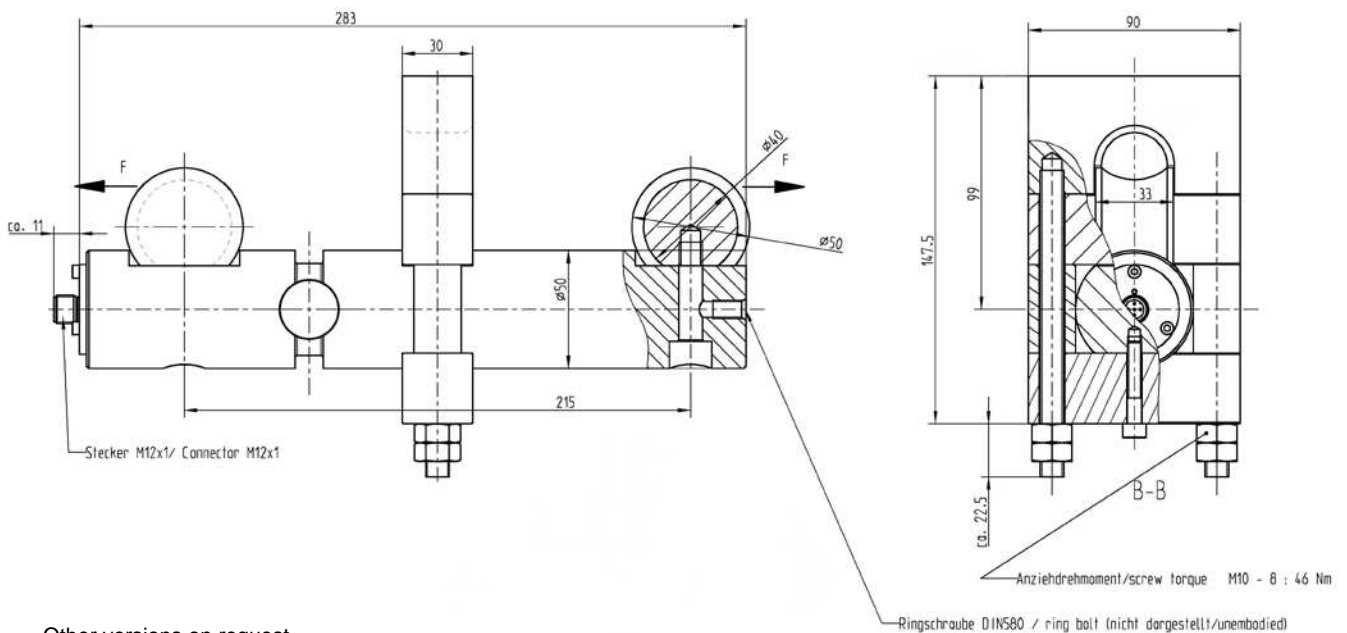

Other versions on request

Electrical connection

Output signal 4..20mA (2-wire)

Circular connector M12x1, 4-pin

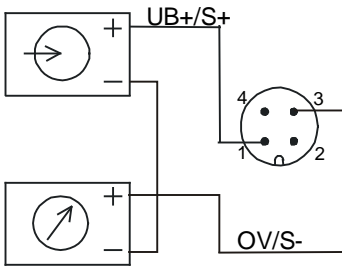

940E01

Cable outlet

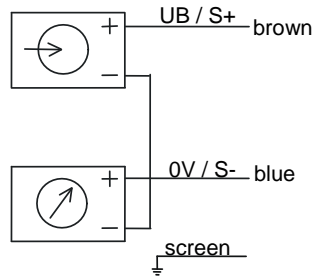

940E03

Output signal 0...10V (3-wire)

Circular connector M12x1, 4-pin

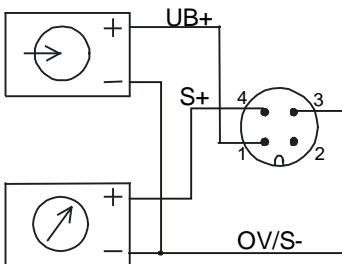

940E04

Cable outlet

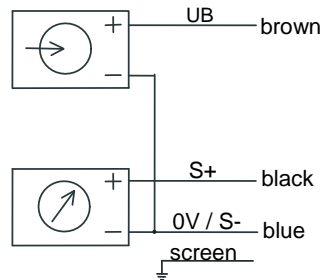

940E06

Pin configuration of connector M12x1 (4-pin) /

Open cable outlet of the tecsis standard connection cable (STL 288, black)

Analogue output Electrical connection	4...20 mA (2 – wire)		0...10 VDC (3 – wire)	
	pin	cable outlet	pin	cable outlet
Supply: UB+	1	brown	1	brown
Supply: 0V	3	blue	3	blue
Signal: S+	1	brown	4	black
Signal: S-	3	blue	3	blue
⊕	thread M12x1	screen	thread M12x1	screen

Subject of technical changes