

Pneumatic pressure balance Model CPB5000



WIKA data sheet CT 31.01



for further approvals
see page 7

Applications

- Primary standard for defining the pressure scale in a pneumatic range of up to 100 bar (1,500 psi) or with a gas to oil separator up to 400 bar (5,000 psi)
- Reference instrument for factory and calibration laboratories for the testing, adjustment and calibration of pressure measuring instruments
- Complete, stand-alone system, also suitable for on-site use

Special features

- Total measurement uncertainty to 0.008 % of reading
- Factory calibration included as standard, traceable to national standards; with DKD/DAkkS calibration possible as an option
- High long-term stability with recommended recalibration interval every five years
- Masses manufactured from stainless steel and aluminium, can be adjusted to local gravity
- Quick and safe replacement of the piston-cylinder system for measuring range changes via patented ConTect quick-release system as an option

Description

Proven primary standard

Pressure balances (dead-weight testers) are the most accurate instruments available on the market for the calibration of electronic or mechanical pressure measuring instruments. The direct measurement of the pressure ($p = F/A$), as well as the use of high-quality materials enable a very small measurement uncertainty, in conjunction with an excellent long-term stability.

The pressure balance (dead-weight tester) has therefore been used for years in factory and calibration laboratories in industry, national institutes and research laboratories.

Stand-alone operation

Due to its integrated pressure generation and the purely mechanical measuring principle, the model CPB5000 is ideal for on-site use for maintenance and service.



Pneumatic pressure balance, model CPB5000

Basic principle

Pressure is defined as the quotient of force and area. The core component of the CPB5000 is therefore a very precisely manufactured piston-cylinder system, onto which a mass load is applied in order to generate the individual test points.

The mass load is proportional to the target pressure and this is achieved through optimally graduated masses. As standard, these masses are manufactured to the standard gravity (9.80665 m/s^2), though they can be adjusted to a specific location and also DKD/DAkkS calibrated.

Easy operation

The pressure setting depends on the instrument version and is either done via an integrated pump or from external pressure supply via a metering valve. For further pressure increases and fine adjustment, a very precisely controllable spindle pump is fitted, which only runs within the pump body.

The piston-cylinder system

Both the piston and cylinder are manufactured from tungsten carbide. This pairing of materials, in comparison to other materials, has very low pressure and temperature coefficients of expansion, which results in a very good linearity for the effective area of the piston and a very high accuracy.

Piston and cylinder are very well protected against contact, impacts or contamination from outside in a solid stainless-steel case. At the same time, overpressure protection is integrated, which prevents the piston from being forced out vertically and avoids damage to the piston-cylinder system in the event of masses removal under pressure.

The masses are stacked on a mass carrier, which sits on the piston shaft. The construction of the mass carrier provides a very low centre of gravity for the stacked masses, which minimises both the side thrust on the piston-cylinder system and the friction. For relatively low starting pressures, a lighter aluminium plate can be used instead of the mass carrier.

The overall design of the piston-cylinder system and the very precise manufacturing of both the piston and the cylinder, ensures excellent operating characteristics with long free-rotation time and low sink rates. Thus a high long-term stability is ensured. Therefore, the recommended recalibration interval is two to five years dependent on the conditions of use.

As soon as the measuring system reaches equilibrium, there is a balance of forces between the pressure and the masses applied. The excellent quality of the system ensures that this pressure remains stable over several minutes, so that the pressure value for comparative measurements can be read without any problems, or also so that more complex adjustments can be carried out on the test item.

The connection of the piston-cylinder system is a M30 x 2 male thread as standard.

The patented ConTect quick-release connector, for easy measuring range changes without the need for tools, is available as an option.

High-performance instrument range

The CPB5000 basic instruments are available in the following three designs:

- Pneumatic base, low pressure
 - up to max. 10 bar (150 psi)
 - with integrated pressure generation through priming pump and spindle pump
- Pneumatic base, high pressure/vacuum
 - up to max. 100 bar (1,500 psi)
 - connection for external pressure supply or vacuum
- Pneumatic base with integrated gas to oil separator
 - up to max. 400 bar (5,000 psi)
 - connection for external pressure supply
 - for use with hydraulic piston-cylinder systems with M30 x 2 connection
 - test items can be easily, dryly and cleanly calibrated with air

As standard, all basic instruments are fitted with a connection for the piston-cylinder system with a M30 x 2 female thread. The optional, integratable, patented ConTect quick-release connector enables a quick and safe changing of the measuring range without tools. Thus one can build a price-optimised complete system out of a universal system base and up to 3 ConTect piston-cylinder systems of different measuring ranges, which can be operated with only one mass set.

The hydraulic measuring ranges of the model CPS5000 piston-cylinder systems can be used on the instrument base of the CPB5800 hydraulic pressure balance. For this, the ConTect quick-release connector is needed.

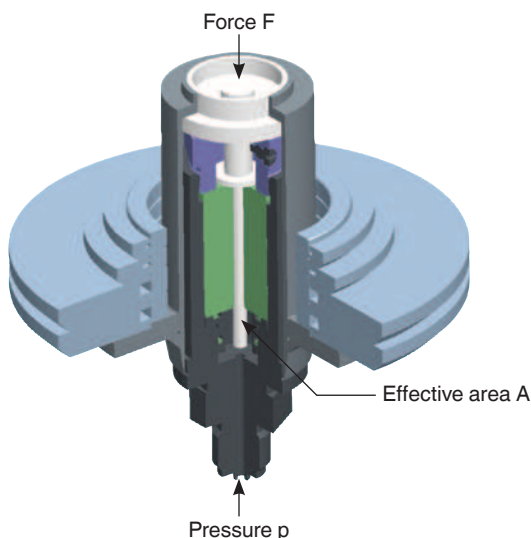

Piston-cylinder system model CPS5000

Tables of masses

The following tables show the number of masses within a mass set with their nominal mass values and the resulting nominal pressures for the respective measuring ranges. Should the instrument not be operated under reference conditions (ambient temperature 20 °C (68 °F), atmospheric pressure 1,013 mbar (14.69 psi), relative humidity 40 %),

the relevant corrections must be made, for example with the CPU6000 CalibratorUnit, see page 9.

The masses are manufactured, as standard, to the standard gravity (9.80665 m/s²) although they can be adjusted for any local gravity.

Pneumatic models

Measuring range [bar]	-0.03 ... -1		0.03 ... 2		0.2 ... 10		0.4 ... 50		0.4 ... 100	
	Quantity	Nominal pressure per piece [bar]	Quantity	Nominal pressure per piece [bar]	Quantity	Nominal pressure per piece [bar]	Quantity	Nominal pressure per piece [bar]	Quantity	Nominal pressure per piece [bar]
Piston	1	0.03	1	0.03	1	0.2	1	0.4	1	0.4
Mass carrier	-	-	1	0.16	1	0.8	1	4	1	4
Piston plate	1	0.07	1	0.01	1	0.05	1	0.25	1	0.25
Masses 4 kg	-	-	-	-	-	-	-	-	-	-
Masses 2 kg	-	-	-	-	-	-	-	-	5	10
Masses 1 kg	-	-	9	0.2	9	1	9	5	9	5
Masses 0.5 kg	8	0.1	1	0.1	1	0.5	1	2.5	1	2.5
Masses 0.25 kg	1	0.05	-	-	-	-	-	-	-	-
Masses 0.2 kg	-	-	1	0.04	1	0.2	1	1	1	1
Masses 0.12 kg	-	-	1	0.024	1	0.12	1	0.6	1	0.6
Masses 0.1 kg	2	0.02	1	0.02	1	0.1	1	0.5	1	0.5
Masses 0.07 kg	-	-	1	0.014	1	0.07	1	0.35	1	0.35
Masses 0.05 kg	1	0.01	1	0.01	1	0.05	1	0.25	1	0.25

Measuring range [psi]	-0.435... -14		0.435... 30		2.9 ... 150		5.8 ... 500		5.8 ... 1,000		5.8 ... 1,500	
	Quantity	Nominal pressure per piece [psi]	Quantity	Nominal pressure per piece [psi]	Quantity	Nominal pressure per piece [psi]	Quantity	Nominal pressure per piece [psi]	Quantity	Nominal pressure per piece [psi]	Quantity	Nominal pressure per piece [psi]
Piston	1	0.435	1	0.435	1	2.9	1	5.8	1	5.8	1	5.8
Mass carrier	-	-	1	2.22	1	11.1	1	55.5	1	55.5	1	55.5
Piston plate	1	0.565	1	0.22	1	1.1	1	5.5	1	5.5	1	5.5
Masses 3.5 kg	-	-	-	-	-	-	-	-	-	-	-	-
Masses 1.4 kg	-	-	5	4	5	20	-	-	5	100	8	100
Masses 1 kg	-	-	2	3	2	15	2	75	2	75	2	75
Masses 0.7 kg	4	2	4	2	4	10	4	50	4	50	9	50
Masses 0.35 kg	4	1	3	1	3	5	3	25	3	25	3	25
Masses 0.19 kg	-	-	1	0.548	1	2.74	1	13.7	1	13.7	1	13.7
Masses 0.175 kg	1	0.5	-	-	-	-	-	-	-	-	-	-
Masses 0.14 kg	-	-	1	0.4	1	2	1	10	1	10	1	10
Masses 0.12 kg	-	-	1	0.345	1	1.725	1	8.625	1	8.625	1	8.625
Masses 0.07 kg	2	0.2	1	0.2	1	1	1	5	1	5	1	5
Masses 0.035 kg	1	0.1	-	-	-	-	-	-	-	-	-	-

Hydraulic models

Measuring range [bar]	0.2 ... 60		0.2 ... 100		1 ... 250		1 ... 400		2 ... 600		2 ... 1,000	
	Quantity	Nominal pressure per piece [bar]	Quantity	Nominal pressure per piece [bar]	Quantity	Nominal pressure per piece [bar]	Quantity	Nominal pressure per piece [bar]	Quantity	Nominal pressure per piece [bar]	Quantity	Nominal pressure per piece [bar]
Piston	1	0.2	1	0.2	1	1	1	1	1	2	1	2
Mass carrier	1	1.6	1	1.6	1	8	1	8	1	16	1	16
Piston plate	1	0.1	1	0.1	1	0.5	1	0.5	1	1	1	1
Masses 4 kg	6	8	11	8	5	40	11	40	6	80	11	80
Masses 2 kg	2	4	2	4	2	20	2	20	2	40	2	40
Masses 1 kg	1	2	1	2	1	10	1	10	1	20	1	20
Masses 0.5 kg	1	1	1	1	1	5	1	5	1	10	1	10
Masses 0.25 kg	-	-	-	-	-	-	-	-	-	-	-	-
Masses 0.2 kg	1	0.4	1	0.4	1	2	1	2	1	4	1	4
Masses 0.12 kg	-	-	-	-	-	-	-	-	-	-	-	-
Masses 0.1 kg	1	0.2	1	0.2	1	1	1	1	1	2	1	2
Masses 0.07 kg	-	-	-	-	-	-	-	-	-	-	-	-
Masses 0.05 kg	1	0.1	1	0.1	1	0.5	1	0.5	1	1	1	1

Measuring range [psi]	2.9 ... 1,000		14.5 ... 5,000		29 ... 10,000		29 ... 14,500	
	Quantity	Nominal pressure per piece [psi]	Quantity	Nominal pressure per piece [psi]	Quantity	Nominal pressure per piece [psi]	Quantity	Nominal pressure per piece [psi]
Piston	1	2.9	1	14.5	1	29	1	29
Mass carrier	1	23.1	1	115.5	1	231	1	231
Piston plate	1	1.1	1	5.5	1	11	1	11
Masses 3.5 kg	9	100	9	500	9	1,000	14	1,000
Masses 1.4 kg	1	40	1	200	1	400	1	400
Masses 1 kg	1	30	1	150	1	300	1	300
Masses 0.7 kg	2	20	2	100	2	200	2	200
Masses 0.35 kg	1	10	1	50	1	100	1	100
Masses 0.19 kg	-	-	-	-	-	-	-	-
Masses 0.175 kg	1	5	1	25	1	50	1	50
Masses 0.14 kg	1	4	1	20	1	40	1	40
Masses 0.12 kg	-	-	-	-	-	-	-	-
Masses 0.07 kg	1	2	1	10	1	20	1	20
Masses 0.035 kg	-	-	-	-	-	-	-	-

Specifications

Piston-cylinder systems model CPS5000							
Pneumatic version							
Measuring range ¹⁾	bar	-0.03 ... -1	0.03 ... 2	0.2 ... 10	0.4 ... 50	0.4 ... 100	
Required masses	kg	5	10	10	10	20	
Smallest step ²⁾ (Standard mass set)	bar	0.01	0.01	0.05	0.25	0.25	
Nominal effective area of the piston	cm ²	5	5	1	0.2	0.2	
Pneumatic version							
Measuring range ¹⁾	psi	-0.435 ... -14	0.435 ... 30	2.9 ... 150	5.8 ... 500	5.8 ... 1,000	5.8 ... 1,500
Required masses	kg	5	10	10	7	13	20
Smallest step ²⁾ (Standard mass set)	psi	0.1	0.2	1	5	5	5
Nominal effective area of the piston	cm ²	5	5	1	0.2	0.2	0.2
Hydraulic version							
Measuring range ¹⁾	bar	0.2 ... 60	0.2 ... 100	1 ... 250	1 ... 400	2 ... 600	2 ... 1,000
Required masses	kg	30	50	25	40	30	50
Smallest step ²⁾ (Standard mass set)	bar	0.1	0.1	0.5	0.5	1	1
Nominal effective area of the piston	cm ²	0.5	0.5	0.1	0.1	0.05	0.05
Hydraulic version							
Measuring range ¹⁾	psi	2.9 ... 1,000	14.5 ... 5,000	29 ... 10,000	29 ... 14,500		
Required masses	kg	34	34	34	50		
Smallest step ²⁾ (Standard mass set)	psi	2	10	20	20		
Nominal effective area of the piston	cm ²	0.5	0.1	0.05	0.05		
Accuracy ³⁾	0.015 % of reading optional: 0.008 % of reading ⁴⁾						
Material							
Piston	Tungsten carbide						
Cylinder	Tungsten carbide						
Mass set	1.4305 stainless steel and aluminium, non-magnetic						
Weight							
Piston-cylinder system (incl. mass carrier and piston plate in optional storage case)	1.5 kg / 5.7 kg (3.3 lbs / 12.6 lbs)						
bar vacuum mass set (incl. piston-cylinder system in carrying case)	13.1 kg (29.0 lbs)						
bar basic mass set, pneumatic (incl. carrying case)	16.2 kg (35.8 lbs)						
bar extension mass set, pneumatic (incl. carrying case)	14.0 kg (30.9 lbs)						
bar basic mass set, hydraulic (incl. carrying case)	36.0 kg (79.6 lbs)						
bar extension mass set, hydraulic (incl. carrying case)	24.0 kg (53.0 lbs)						
psi vacuum mass set (incl. piston-cylinder system in carrying case)	13.0 kg (28.7 lbs)						
psi basic mass set, pneumatic (incl. carrying case)	12.5 kg (27.6 lbs)						

1) Theoretical starting value; corresponds to the pressure value generated by the piston (by its own weight). To optimise the operating characteristics more masses should be loaded.

2) The smallest pressure change value that can be achieved based on the standard mass set. To reduce this, a set of fine increment masses is also available.

3) The accuracy from 10 % of the measuring range is based on the measured value. In the lower range, a fixed error based on 10 % of the range applies.

4) Measurement uncertainty assuming reference conditions (ambient temperature 20 °C (68 °F), atmospheric pressure 1,013 mbar (14.69 psi), relative humidity 40 %). For operation without a CalibratorUnit, corrections must be made if required.

Piston-cylinder systems model CPS5000



psi extension mass set 1, pneumatic (incl. carrying case)	11.0 kg (24.3 lbs)
psi extension mass set 2, pneumatic (only for 1,500 psi) (incl. carrying case)	18.5 kg (40.9 lbs)
psi basic mass set, hydraulic (incl. carrying case)	42.0 kg (92.8 lbs)
psi extension mass set, hydraulic (incl. carrying case)	21.5 kg (47.5 lbs)
Dimensions (W x H x D)	
Carrying case for basic mass set	400 x 310 x 310 mm (15.8 x 12.2 x 12.2 in)
Carrying case for extension mass set	215 x 310 x 310 mm (8.5 x 12.2 x 12.2 in)
Storage case for the piston-cylinder system (optional)	300 x 265 x 205 mm (11.8 x 10.4 x 8.1 in)

- 1) Theoretical starting value; corresponds to the pressure value generated by the piston (by its own weight). To optimise the operating characteristics more masses should be loaded.
- 2) The smallest pressure change value that can be achieved based on the standard mass set. To reduce this, a set of fine increment masses is also available.
- 3) The accuracy from 10 % of the measuring range is based on the measured value. In the lower range, a fixed error based on 10 % of the range applies.
- 4) Measurement uncertainty assuming reference conditions (ambient temperature 20 °C (68 °F), atmospheric pressure 1,013 mbar (14.69 psi), relative humidity 40 %). For operation without a CalibratorUnit, corrections must be made if required.

Base, model CPB5000

Base version	
Pneumatic, low pressure	up to max. 10 bar (150 psi); with internal pressure generation
Pneumatic, high pressure/vacuum	up to max. 100 bar (1,500 psi); for external supply and vacuum
Pneumatic, with separator	up to max. 400 bar (5,000 psi); for external supply with integrated gas to oil separator for use with hydraulic pistons with M30 x 2 connection
Pressure transmission medium	
Pneumatic	Clean, dry, non-corrosive gases (e.g. air or nitrogen)
Connections	
Connection for piston-cylinder system	Standard: M30 x 2 female thread Option: ConTect quick-release connector
Test item connection	Quick connector G ½ B female thread as standard, freely rotating, changeable, for further threaded inserts, see accessories
External pressure connection	6 mm SWAGELOK® threaded pipe connection; max. 110 % of the assigned measuring range; only with pneumatic high-pressure/vacuum base version and with separator
Material	
Piping in base	pneumatic low pressure: plastic tubing from polyurethane, 4 x 0.75 mm pneumatic high pressure/vacuum and with separator: 1.4571 stainless steel, 3 x 1 mm
Weight	
Pneumatic base, low pressure (incl. optional ConTect quick-release connector)	18.0 kg / 19.0 kg / (39.8 lbs / 42.0 lbs)
Pneumatic base, high pressure (incl. optional ConTect quick-release connector)	18.0 kg / 19.0 kg / (39.8 lbs / 42.0 lbs)
Pneumatic base, separator	16.5 kg (36.5 lbs)
Permissible ambient conditions	
Operating temperature	18 ... 28 °C (64 ... 82 °F)
Dimensions (W x H x D)	
Base	401 x 375 x 265 mm (15.8 x 14.8 x 10.4 in), for details, see technical drawings

Approvals

Logo	Description	Country
	EC declaration of conformity Pressure equipment directive	European Community
	Uzstandard Metrology/measurement technology	Uzbekistan
-	MTSCHS Permission for commissioning	Kazakhstan

Certificates

Certificate	
Calibration	Standard: 3.1 calibration certificate per DIN EN 10204 Option: DKD/DAkkS calibration certificate
Recommended recalibration interval	2 to 5 years (dependent on conditions of use)

Approvals and certificates, see website

Transport dimensions for complete instrument

The complete instrument, in its standard version and standard scope of delivery, consists of 3 packages on a single pallet. The dimensions are 1,200 x 800 x 500 mm (47.3 x 31.5 x 19.7 in). The overall weight is dependent on the measuring range.

Version in bar	Weight	
	net	gross
Pneumatic		
-1 bar	32.5 kg (71.8 lbs)	47.5 kg (105.0 lbs)
2 bar / 10 bar / 50 bar	36.0 kg (79.6 lbs)	51.0 kg (112.7 lbs)
100 bar	50.0 kg (110.5 lbs)	65.0 kg (143.7 lbs)
Pneumatic with separator		
60 bar / 250 bar	54.0 kg (119.3 lbs)	69.0 kg (152.5 lbs)
100 bar / 400 bar	78.0 kg (172.4 lbs)	93.0 kg (205.5 lbs)
Hydraulic with CPB5800 base		
60 bar / 250 bar / 600 bar	56.5 kg (124.9 lbs)	71.5 kg (158.0 lbs)
100 bar / 400 bar / 1,000 bar	80.5 kg (177.9 lbs)	95.5 kg (211.1 lbs)

Version in psi	Weight	
	net	gross
Pneumatic		
-14 psi	32.0 kg (70.7 lbs)	47.0 kg (103.9 lbs)
30 psi / 150 psi / 1,000 psi	43.0 kg (95.0 lbs)	58.0 kg (128.2 lbs)
500 psi	32.0 kg (70.7 lbs)	47.0 kg (103.9 lbs)
1,500 psi	61.5 kg (135.9 lbs)	76.5 kg (169.1 lbs)
Pneumatic with separator		
1,000 psi / 5,000 psi	60.0 kg (132.6 lbs)	75.0 kg (165.8 lbs)
Hydraulic with CPB5800 base		
1,000 psi / 5,000 psi / 10,000 psi	62.5 kg (138.1 lbs)	77.5 kg (171.3 lbs)
14,500 psi	84.0 kg (185.6 lbs)	99.0 kg (218.8 lbs)

Dimensions in mm (in)

The figure shows a CPB5000 pneumatic high-pressure base unit with the ConTect quick-release connector option. The versions for pneumatic low pressure and pneumatic with integrated gas to oil separator do not differ from it dimensionally, only in the arrangement of the control elements.

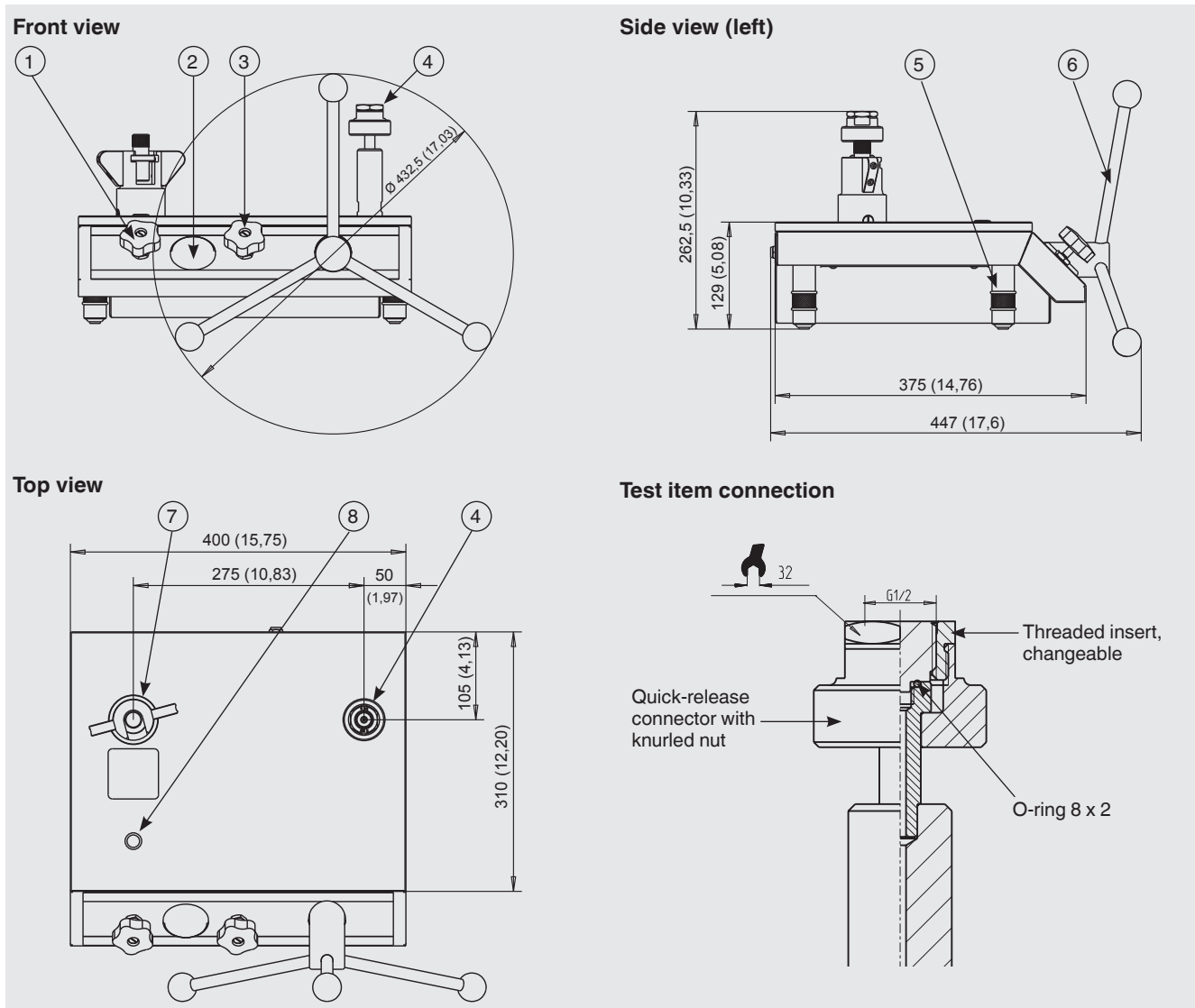

Pneumatic base, low pressure

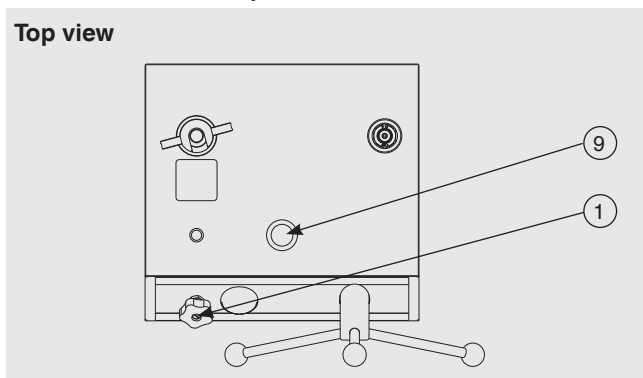

- ① Outlet valve
- ② Test pressure gauge
- ③ Inlet valve (not for pneumatic low pressure)
- ④ Test item connection
- ⑤ Rotatable feet

Pneumatic base with integrated gas to oil separator

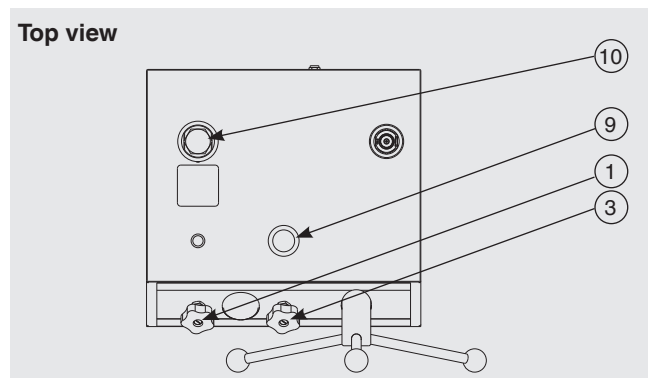

- ⑥ Spindle pump with star handle, removable
- ⑦ Connector for piston-cylinder system
- ⑧ Level
- ⑨ Priming pump
- ⑩ Connector for piston-cylinder system with integrated gas to oil separator

CalibratorUnit model CPU6000

The models of the CPU6000 series are compact tools for use with a pressure balance (dead-weight tester). In particular when highly accurate measuring values, with measurement uncertainties of less than 0.025 %, are required, complicated mathematical calculations and corrections are necessary. With the CPU6000 in combination with the CPB-CAL (iPad® app) and/or WIKA-CAL (PC software) all critical ambient parameters can be registered and automatically corrected.

The CPU6000 series is made up of three instruments

Weather station, model CPU6000-W

The CPU6000-W provides measured values such as atmospheric pressure, relative humidity and the ambient temperature of the laboratory environment.

Pressure balance sensor box, model CPU6000-S

The CPU6000-S measures the piston temperature and displays the floating position of the masses.

Digital multimeter, model CPU6000-M

The CPU6000-M fulfils the function of a digital multimeter and power supply unit when electronic pressure transmitters must be calibrated.

Typical application

CPB-CAL iPad® app

The iPad® application calculates the masses for pressure balances (dead-weight testers) or the reference pressure while taking the measured parameters from the CPU6000 into account. The conversion can be carried out in all common pressure units. As an additional parameter, the local gravity can be given for location-independent measurements.

WIKA-CAL PC software - Weight calculator

With the demo version of the WIKA-CAL software and a CPB series pressure balance (dead-weight tester), the masses to be applied and the corresponding reference pressure can be determined. The pressure balance data (dead-weight tester data) can be entered into the database manually or imported automatically via an XML file available online.

All ambient parameters and piston temperature can be entered manually into WIKA-CAL or can be measured automatically with the CPU6000 series, so that the highest accuracy can be achieved. WIKA-CAL demo version can be downloaded free of charge from the WIKA website.

Further specifications on the CPU6000 series can be found in data sheet CT 35.02.

For details of the WIKA-CAL calibration software see data sheet CT 95.10.



CPU6000 series and iPad® app CPB-CAL



Model CPU6000-W, CPU6000-S, CPB5800 and PC with WIKA-CAL software

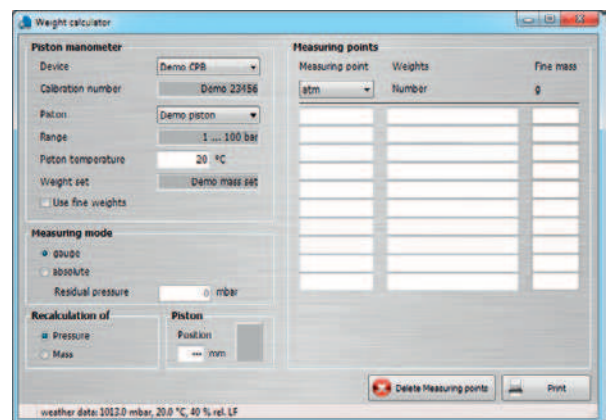

WIKA-CAL PC software - Weight calculator

Further pressure balances / dead-weight testers within our calibration technology programme

Dead-weight tester in compact design, model CPB3800

Measuring ranges:

Hydraulic 1 ... 120 to 10 ... 1,200 bar
(10 ... 1,600 to 100 ... 16,000 psi)

Accuracy: 0.05 % of reading
0.025 % of reading (optional)

For specifications see data sheet CT 31.06



Dead-weight tester in compact design, model CPB3800

Hydraulic pressure balance, model CPB5800

Measuring ranges:

Hydraulic Single-piston measuring ranges:
1 ... 120 to 2 ... 300 bar
(10 ... 1,600 to 30 ... 4,000 psi)

Dual-piston measuring ranges:

1 ... 60 bar / 10 ... 700 bar to
1 ... 60 bar / 20 ... 1,400 bar
(10 ... 800 psi / 100 ... 10,000 psi to
10 ... 800 psi / 200 ... 20,000 psi)

Accuracy: 0.015 % of reading
up to 0.006 % of reading (optional)

For specifications see data sheet CT 31.11



Hydraulic pressure balance, model CPB5800

Pressure balance for high pressure, model CPB5000HP

Measuring ranges:

Hydraulic 25 ... 2,500, 25 ... 4,000 or 25 ... 5,000 bar
(350 ... 40,000, 350 ... 60,000 or
350 ... 70,000 psi)

Accuracy: 0.025 % of reading
0.02 % of reading (optional)

For specifications see data sheet CT 31.51



Pressure balance for high pressure, model CPB5000HP

Pressure balance for differential pressure, model CPB5600DP

Measuring ranges (= static pressure + differential pressure):

Pneumatic 0.03 ... 2 to 0.4 ... 100 bar
(0.435 ... 30 to 5.8 ... 1,500 psi)

Hydraulic 0.2 ... 60 to 25 ... 1,600 bar
(2.9 ... 1,000 to 350 ... 23,200 psi)

Accuracy: 0.015 % of reading
0.008 % of reading (optional)

For specifications see data sheet CT 31.56



Pressure balance for differential pressure, model CPB5600DP

Accessories

Set of fine increment masses M1 and F1

The masses included in the standard scope of delivery are ideally suited for everyday use. If even smaller intermediate values need to be generated, using one of the class M1 or F1 set of fine increment masses with the following masses is recommended:

1 x 50 g, 2 x 20 g, 1 x 10 g, 1 x 5 g, 2 x 2 g, 1 x 1 g,
1 x 500 mg, 2 x 200 mg, 1 x 100 mg, 1 x 50 mg, 2 x 20 mg,
1 x 10 mg, 1 x 5 mg, 2 x 2 mg, 1 x 1 mg



Set of fine increment masses

Adapter sets for quick-release connector

As a standard, the pressure balance is equipped with a quick-release connector for connecting the test item. For this purpose, the following threaded inserts, which can be easily changed, are available:

- Adapter set: G ¼, G ⅜, ½ NPT, ¾ NPT and M20 x 1.5
- Adapter set NPT: ⅛ NPT, ¼ NPT, ⅜ NPT and ½ NPT

Additionally, the adapter sets include spare O-rings as well as a spanner with SW32 flats and SW14 flats, for changing the adapters.

Other threaded inserts are available on request.



Adapter set

Dirt trap

For strongly soiled test items, a dirt trap should be used. This helps prevent the ingress of contaminants into the pressure balance.



Dirt trap

Designation/Version	Order no.
Set of fine increment masses (1 mg up to 50 g), class F1	7093874
Set of fine increment masses (1 mg up to 50 g), class M1	14025325
Adapter set for quick-release connector in case with G ¼, G ⅜, ½ NPT, ¾ NPT and M20 x 1.5 threaded inserts for insertion in the knurled nut on the test item connector	2036941
Adapter set "NPT" for quick-release connector in case with ⅛ NPT, ¼ NPT, ⅜ NPT and ½ NPT threaded inserts for insertion in the knurled nut on the test item connector	12563626
90° angle connection, for test items with back mounting connection	1564838
Dirt trap, -1 ... +1,000 bar (14,500 psi), volume 0.2 litre	2015820
Dirt trap, -1 ... +1,000 bar (14,500 psi), volume 0.03 litre	2015714
O-ring set consisting of 5 pcs. 8 x 2 and 5 pcs. 4 x 2.2	12328562
Operating fluid for CPB5000 up to max. 4,000 bar (60,000 psi), 1 litre	2099882
Cleaning set for ConTect systems, pneumatic	12485943
Cleaning set for ConTect systems, hydraulic	12481425
Special test port with quick-release connector, for connection to the ConTect system entry, operation as a comparison test pump is possible	2152634

Scope of delivery

- Base with dust protection cover
- Priming pump (not on pneumatic base high pressure/ vacuum)
- Spindle pump for filling, pressure generation and fine pressure adjustment
- Piston connection with M30 x 2 female thread
- Quick connector for test items
- Piston-cylinder system with mass carrier
- Basic mass set in carrying case
- Extension mass set in carrying case (depending on the measuring range)
- Masses manufactured to local gravity (standard value: 9.80665 m/s²)
- VG22 mineral oil, 0.25 litre (for separator version)
- Sealing set for base CPB5000
- Operating instructions in German and English language
- Factory calibration certificate

Options

- Systems with increased accuracy to 0.008 %
- Further pressure units
- Piston connection with ConTect quick-release connector
- Storage case for piston-cylinder systems
- Masses, manufactured to local gravity
- Tool set
- DKD/DAkkS calibration certificate

Ordering information

Instrument base

CPB5000 / Instrument version / Connection of the piston-cylinder system / Piston-cylinder system / Mass set in carrying case / Calibration for mass set / Additional ordering information

Piston-cylinder system

CPS5000 / Version / Connection of the piston-cylinder system / Accuracy / Measuring range / Storage case for piston-cylinder systems / Calibration for ConTect system / Additional ordering information

© 2008 WIKA Alexander Wiegand SE & Co. KG, all rights reserved.
The specifications given in this document represent the state of engineering at the time of publishing.
We reserve the right to make modifications to the specifications and materials.

