

Infrared calibrator Model CTI5000

WIKA data sheet CT 41.42



for further approvals see
page 2

Applications

- Testing and calibration of non-contact temperature measuring instruments
- Heating source for on-site laboratories for the calibration of infrared thermometers
- Also suitable for on-site calibration

Special features

- Testing of infrared thermometers across a wide temperature range; 50 ... 500 °C (122 ... 932 °F)
- Large surface area of the black body (Ø 57 mm / 2.24 in) for all types of pyrometers
- Bore to accept a reference sensor
- Low weight and compact design
- Simple operation



Infrared calibrator, model CTI5000

Description

Aim – shoot – test

For the calibration of infrared thermometers above ambient temperature, the model CTI5000 is suitable up to 500 °C (932 °F). Due to its stability, the new portable infrared calibrator is particularly suited to the calibration of infrared hand-held thermometers.

The black body has a large diameter so that a wide variety of infrared thermometers can be tested, no matter which lenses are fitted.





The emissivity is fixed at 0.95 and the temperature can be controlled in steps of 0.1 °C.

To check the black body, there is a bore located directly behind the surface so that the measurement can be made with contact and the quality monitored.

Specifications Model CTI5000

Infrared calibrator	
Indication	
Application range	50 ... 500 °C (122 ... 932 °F)
Stability	±0.1 K to 100 °C (212 °F) ±0.2 K to 350 °C (662 °F) ±0.4 K to 500 °C (932 °F)
Resolution	0.1 K
Temperature control	
Heating time	30 min from T _{amb.} to 500 °C (T _{amb.} to 932 °F)
Cooling time	40 min from 500 °C to 100 °C (from 932 °F to 212 °F)
Stabilisation time	approx. 15 ... 20 min
Measuring surface	
Emissivity	0.95
Diameter of the measuring surface	57 mm (2.24 in)
Permissible ambient conditions	
Relative humidity	35 ... 85 % r. h. (non-condensing)
Operating temperature	5 ... 35 °C (41 ... 95 °F)
Voltage supply	
Power supply	AC 230 V, 50/60 Hz
Power consumption	275 VA
Case	
Dimensions (W x D x H)	190 x 248 x 113 mm (7.5 x 9.8 x 4.5 in)
Weight	2.1 kg (4.6 lbs)

Approvals

Logo	Description	Country
	EU declaration of conformity ■ EMC directive ■ Low voltage directive ■ RoHS directive	European Union
	EAC ■ EMC directive ■ Low voltage directive	Eurasian Economic Community
-	MTSCHS Permission for commissioning	Kazakhstan
	BelGIM Metrology, measurement technology	Belarus
	Uzstandard Metrology, measurement technology	Uzbekistan

Approvals and certificates, see website

Dimensions in mm (in)

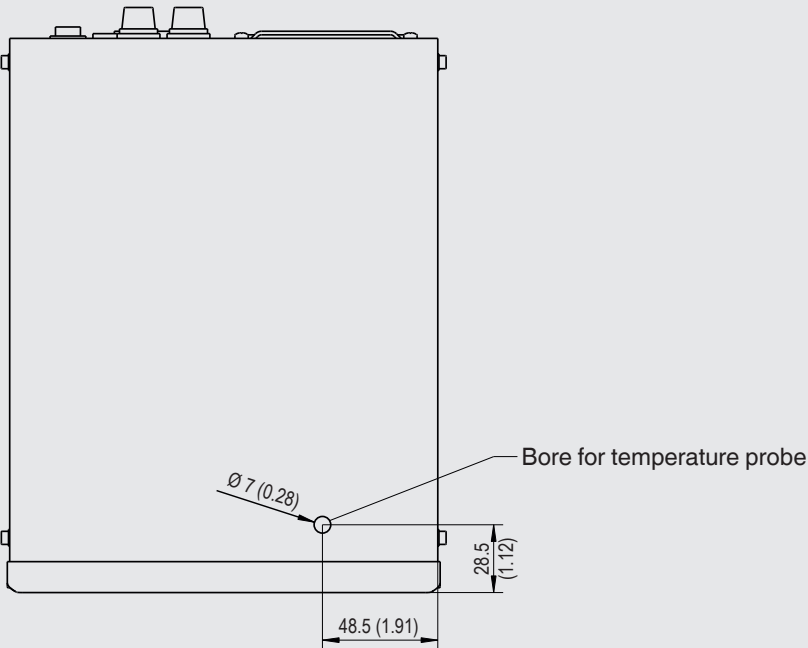
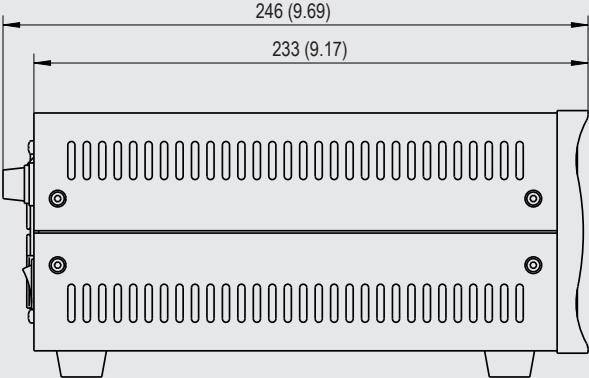
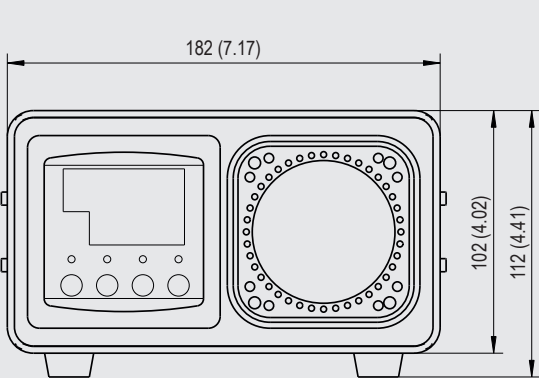

Controls

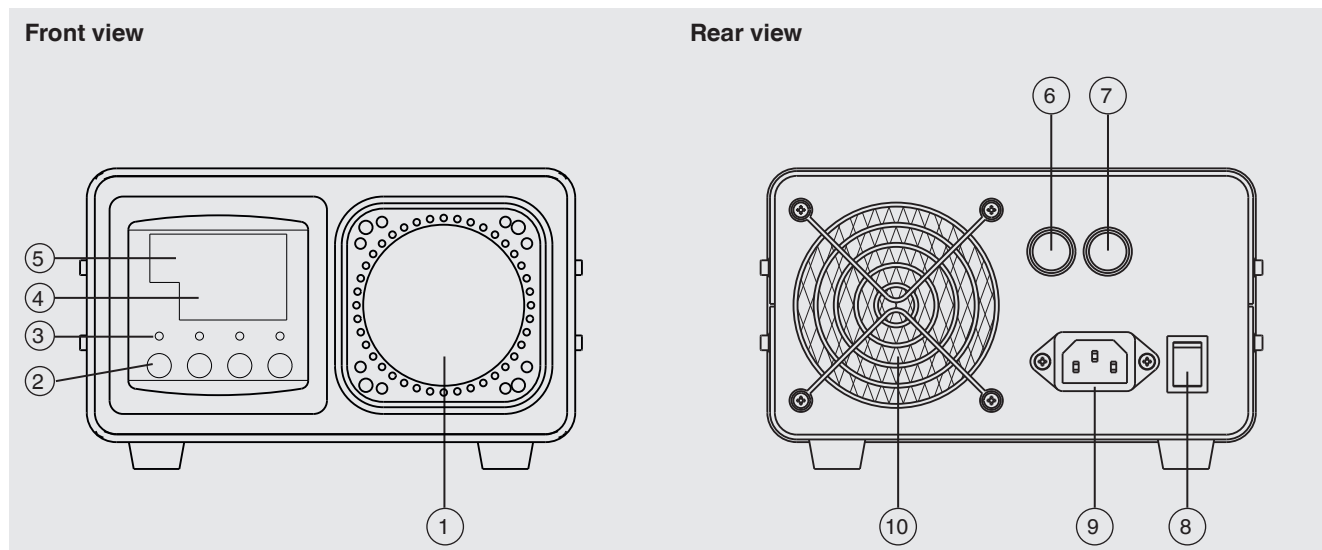

- | | |
|--------------------------------------------------------|---------------------------|
| ① Measuring surface | ⑥ Fuse for the heating |
| ② Control panel | ⑦ Fuse for the control |
| ③ Status LED's | ⑧ ON/OFF switch |
| ④ Indication of the currently-selected set temperature | ⑨ Mains connection socket |
| ⑤ Indication of the current block temperature | ⑩ Fan |

Scope of delivery

- Infrared calibrator model CTI5000
- Operating instructions
- Power cord

Ordering information

Model / Mains voltage / Further approvals / Additional ordering information

© 03/2009 WIKA Alexander Wiegand SE & Co. KG, all rights reserved.
The specifications given in this document represent the state of engineering at the time of publishing.
We reserve the right to make modifications to the specifications and materials.



WIKAL Alexander Wiegand SE & Co. KG
Alexander-Wiegand-Straße 30
63911 Klingenberg/Germany
Tel. +49 9372 132-0
Fax +49 9372 132-406
info@wika.de
www.wika.de