

Hydraulic test pumps

Models CPP1000-M, CPP1000-L, hand spindle pump

Models CPP1000-X, CPP1600-X, CPP7000-X, comparison test pump

WIKA data sheet CT 91.05

EAC

Applications

- Simple test pressure generation on site, in the laboratory or in the workshop
- For the testing, adjustment and calibration of all types of pressure measuring instruments
- Hydraulic pressure generation up to 7,000 bar (100,000 psi)

Special features

- Ergonomic handling through the smooth-running, internally operating, precision spindle
- Integrated oil reservoir
- Removable star handle
- Freely rotating test connections (i.e. measuring instruments can be aligned)
- Proven technology of the model CPB5800 pressure balance

Description

Application areas

Test pumps serve as pressure generators for the testing, adjustment and calibration of mechanical and electronic pressure measuring instruments through comparative measurements. These pressure tests can take place in the laboratory or workshop, or on site at the measuring point.

Easy operation

If one connects the test item and a sufficiently accurate reference measuring instrument to the test pump, on actuating the pump, the same pressure will act on both instruments. By comparison of the two measured values at any given pressure value, a check of the accuracy and/or adjustment of the pressure measuring instrument under test can be carried out.

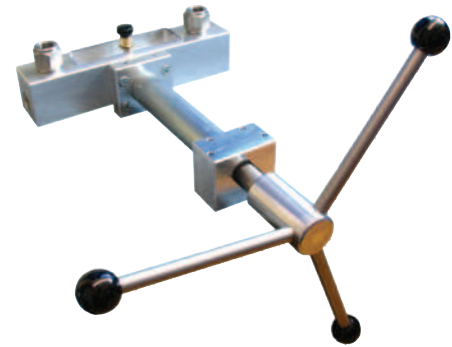

Hand spindle pump, model CPP1000-M



Comparison test pump, model CPP1000-X

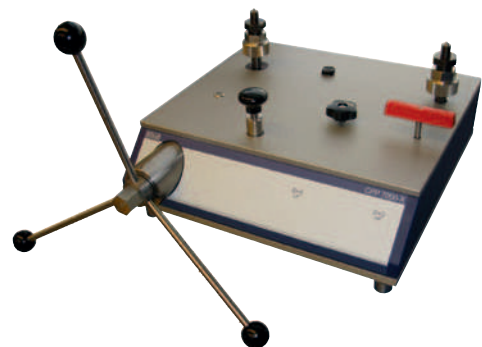

Comparison test pump, model CPP7000-X

CPP-X series offers exceptional ease-of-use

For a precise approach to the measuring points, the test pumps are fitted with a spindle for fine control. In particular, the smooth running of the hand spindle enables this, even at very high pressures. Furthermore, the spindles for this model range only run within the pump body.

This eliminates any harmful bending moment from an externally running spindle and, especially for field operation, there is the advantage that dimensions of these pumps do not alter during operation through the rotation of the spindle.

With the integrated priming pump, large test volumes can be easily filled and primed for the models CPP-X.

Due to the design of the base, the CPP-X models have a high durability and offer the highest ease-of-use with the proven technology of the model CPB5800 pressure balance.

Specifications Hand spindle pump

	CPP1000-M	CPP1000-L
Pressure range	0 ... 1,000 bar (0 ... 14,500 psi)	
Pressure transmission medium	Hydraulic fluid based on mineral oil or single distilled water ¹⁾ (water-based hydraulic fluids are not suitable)	
Reservoir	110 cm ³	55 cm ³
Pressure connections		
Test connection	2 x G ½ female thread, freely rotating, with O-ring	
Distance between test connections	200 mm (7.9 in)	115 mm (4.5 in)
Piston of spindle pump		
Piston diameter	8 mm (0.3 in)	
Swept volume per revolution	approx. 0.1 cm ³	
Overall swept volume	approx. 3.9 cm ³	
Fine pressure adjustment	optional, see accessories	Fine adjustment valve on the side
Required force at		
250 bar (3,600 psi)	2.0 Nm	
500 bar (7,200 psi)	4.0 Nm	
1,000 bar (14,500 psi)	8.0 Nm	
Material		
Cylinder	Brass	
Piston	Stainless steel	
Rear flange	Aluminium	
Sealings	FKM, NBR (standard), optional EPDM ²⁾	
Stationary mounting	2 x Ø 6.4 mm (0.25 in) through-bores in the front flange	
Instrument base		
Dimensions (L x W x H)	420 x 280 x 103 mm (16.5 x 11.0 x 4.1 in)	420 x 240 x 103 mm (16.5 x 9.5 x 4.1 in)
Weight	6.3 kg (13.89 lbs.)	5.6 kg (12.35 lbs.)

1) Other pressure transmission media on request.

2) Using the EPDM variant (for aggressive media), Skydrol® or brake fluid is permissible as pressure transmission medium.



Comparison test pump

	CPP1000-X	CPP1600-X	CPP7000-X
Pressure range	0 ... 1,000 bar (0 ... 14,500 psi)	0 ... 1,600 bar (0 ... 23,200 psi)	0 ... 7,000 bar (0 ... 100,000 psi)
Pressure transmission medium	Hydraulic fluid based on mineral oil / clean water, free of calcium-carbonate ¹⁾		Sebacate oil
Reservoir	250 cm ³		250 cm ³
Pressure connections			
Test connection	2 x G ½ female threaded quick-connectors, freely rotating, exchangeable, with O-ring		2 x M16 x 1.5 male thread, freely rotating, exchangeable, with sealing cone
Distance between test connections	300 mm (11.8 in)		346 mm (13.6 in)
Piston of the comparison test pump			
Piston diameter	8 mm (0.3 in)		7.5 mm (0.3 in)
Swept volume per revolution	approx. 0.1 cm ³		approx. 0.08 cm ³
Overall swept volume	approx. 3.9 cm ³		approx. 2.5 cm ³
Required force at			
250 bar (3,600 psi)	2.0 Nm		1.5 Nm
500 bar (7,200 psi)	4.0 Nm		3.0 Nm
1,000 bar (14,500 psi)	8.0 Nm		6.0 Nm
3,000 bar (43,500 psi)	--		18 Nm
5,000 bar (72,500 psi)	--		30 Nm
7,000 bar (100,000 psi)	--		42 Nm
Material			
Cylinder	Brass		Stainless steel
Piston	Stainless steel		hardened stainless steel
Piping	1.4404 stainless steel, 6 x 2 mm (0.2 x 0.1 in)		1.4404 stainless steel, 6 x 2 mm (0.2 x 0.1 in)
Rear flange	Aluminium		--
Sealings	FKM, NBR (standard), optional EPDM ²⁾		NBR
Stationary mounting	Stable base		Stable base
Instrument base			
Dimensions (L x W x H)	400 x 375 x 265 mm (15.8 x 14.8 x 10.4 in)		460 x 445 x 265 mm (18.1 x 17.5 x 10.4 in)
Weight	20 kg (44.1 lbs.)		32,5 kg (71.7 lbs.)

1) Other pressure transmission media on request.

2) Using the EPDM variant (for aggressive media), Skydrol® or brake fluid is permissible as pressure transmission medium.

Approvals

Logo	Description	Country
	EC declaration of conformity for model CPP1600-X Pressure equipment directive (PS > 1,000 bar; module A, pressure accessory)	European Community
	EAC ■ Pressure equipment directive ■ Machinery directive	Eurasian Economic Community

Approvals and certificates, see website

Hand spindle pump model CPP1000 version M and L, up to 1,000 bar (14,500 psi), hydraulic

The model CPP1000-M and CPP1000-L hand spindle pumps, with their compact size and low weight, are the basic versions in the CPP series of test pumps.

They have been designed primarily for the test and calibration of pressure measuring instruments with small volumes. Test items and reference instruments with larger volumes should either be pre-filled offline from the test pump or also simply and conveniently filled directly from the hand spindle pump, using the shut-off valves available as an accessory for the test connections.

The CPP1000-L is the case version with a narrow rear flange, sealed reservoir and a fine adjustment valve built-in as standard.

For the CPP1000-M, the fine adjustment valve is available as an accessory and can be fitted as an option. When using the fine adjustment valve, only one shut-off valve can be fitted for one test connection.

The test connections are G ½ female. Corresponding thread adapters are available for the calibration of instruments with different connection threads.

Dimensions in mm (in)

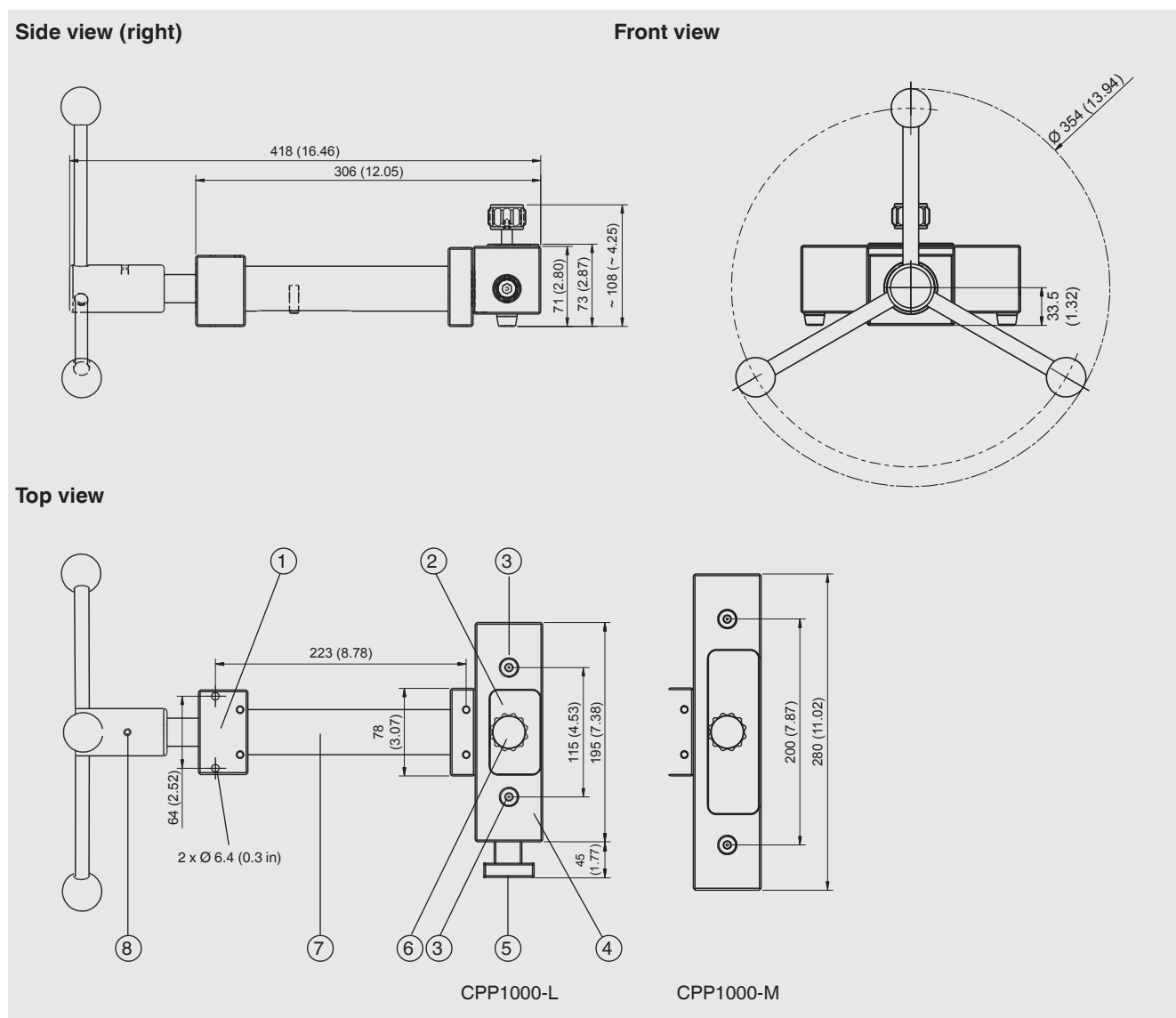

- ① Front flange with 2 fixing bores, $\varnothing 6.4$ mm (0,3 in)
- ② Medium reservoir
- ③ Test connection, G ½ female thread, freely rotating, with O-ring
- ④ Rear flange
- ⑤ Fine adjustment valve (at CPP1000-M as an option)
- ⑥ Shut-off valve for reservoir (optional)
- ⑦ Cylinder with spindle and piston
- ⑧ Star handle with spring-loaded thrust pad

Comparison test pumps models CPP1000-X and CPP1600-X, up to 1,000 bar (14,500 psi) or 1,600 bar (23,200 psi), hydraulic

The model CPP1000-X and CPP1600-X comparison test pumps have been designed around a solid base and, with the proven technology of the CPB5800 pressure balance, offer exceptional ease-of-use. With the integrated priming pump and the 250 ml tank, large test volumes can also be easily filled and primed.

Both test connections on both pump models are fitted with quick-release connectors with knurled nuts and exchangeable threaded inserts (as standard G ½ female thread). Corresponding threaded inserts are available for the calibration of instruments with different connection threads.

Dimensions in mm (in)

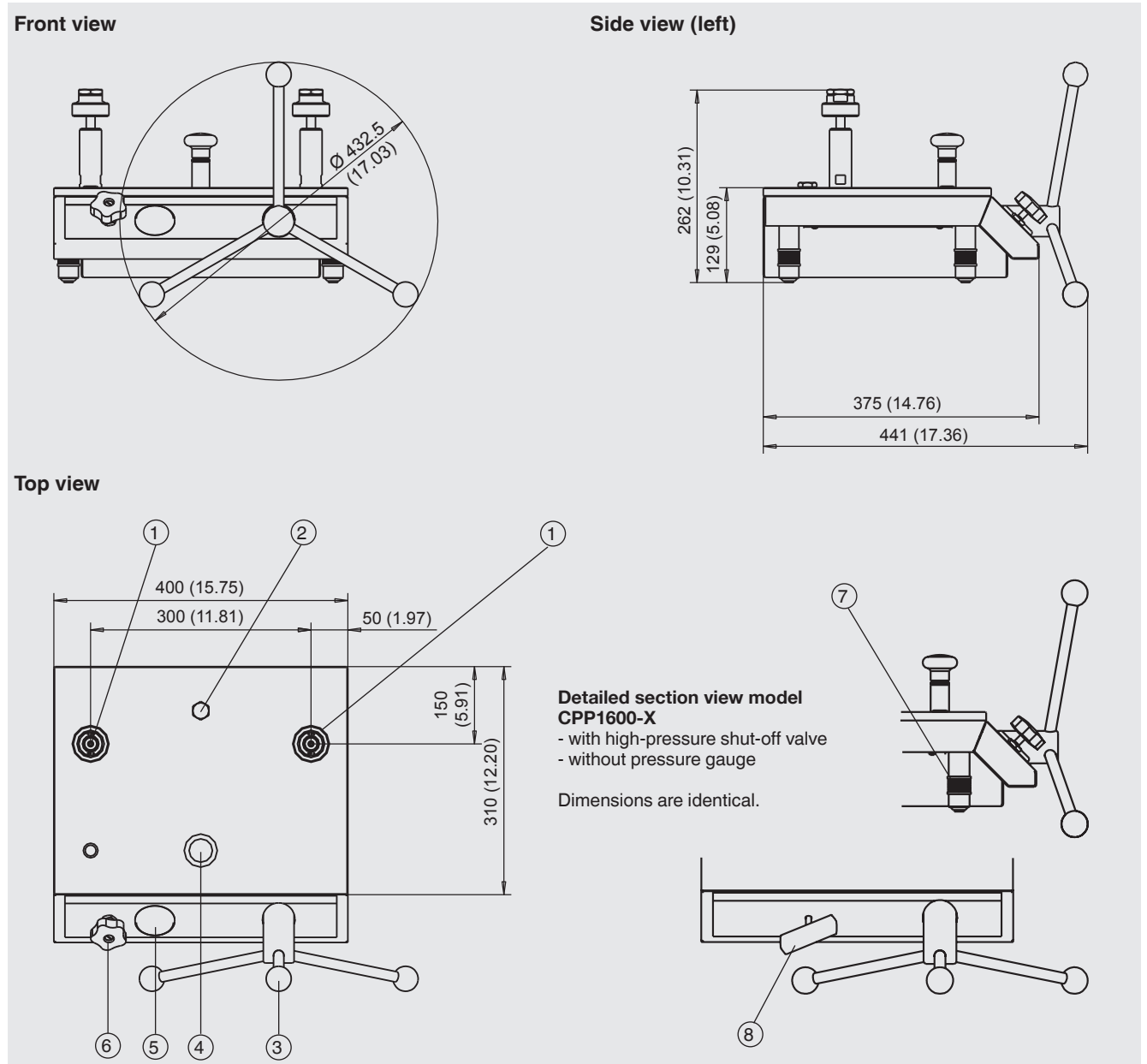

- ① Test connections (quick-release connector with G ½ female thread, exchangeable, freely rotating, with O-ring)
- ② Plug screw for medium reservoir
- ③ Spindle pump with star handle
- ④ Priming pump
- ⑤ Test pressure gauge
- ⑥ Shut-off valve 1,000 bar (14,500 psi)
- ⑦ Rotatable feet
- ⑧ High-pressure shut-off valve 1,600 bar (23,200 psi)

Comparison test pump model CPP7000-X, up to 7,000 bar (100,000 psi), hydraulic

The model CPP7000-X comparison test pump has been designed around a solid base and, with the proven technology of the CPB5000HP high-pressure pressure balance, offers exceptional ease-of-use. With the integrated priming pump and the 250 ml tank, large test volumes can also be easily filled and primed.

Both test connections are fitted with knurled nuts and exchangeable thread adapters with sealing cones (as standard M16 x 1.5 male threads). Corresponding thread adapters are available as accessories for the calibration of instruments with other connection threads.

Dimensions in mm (in)

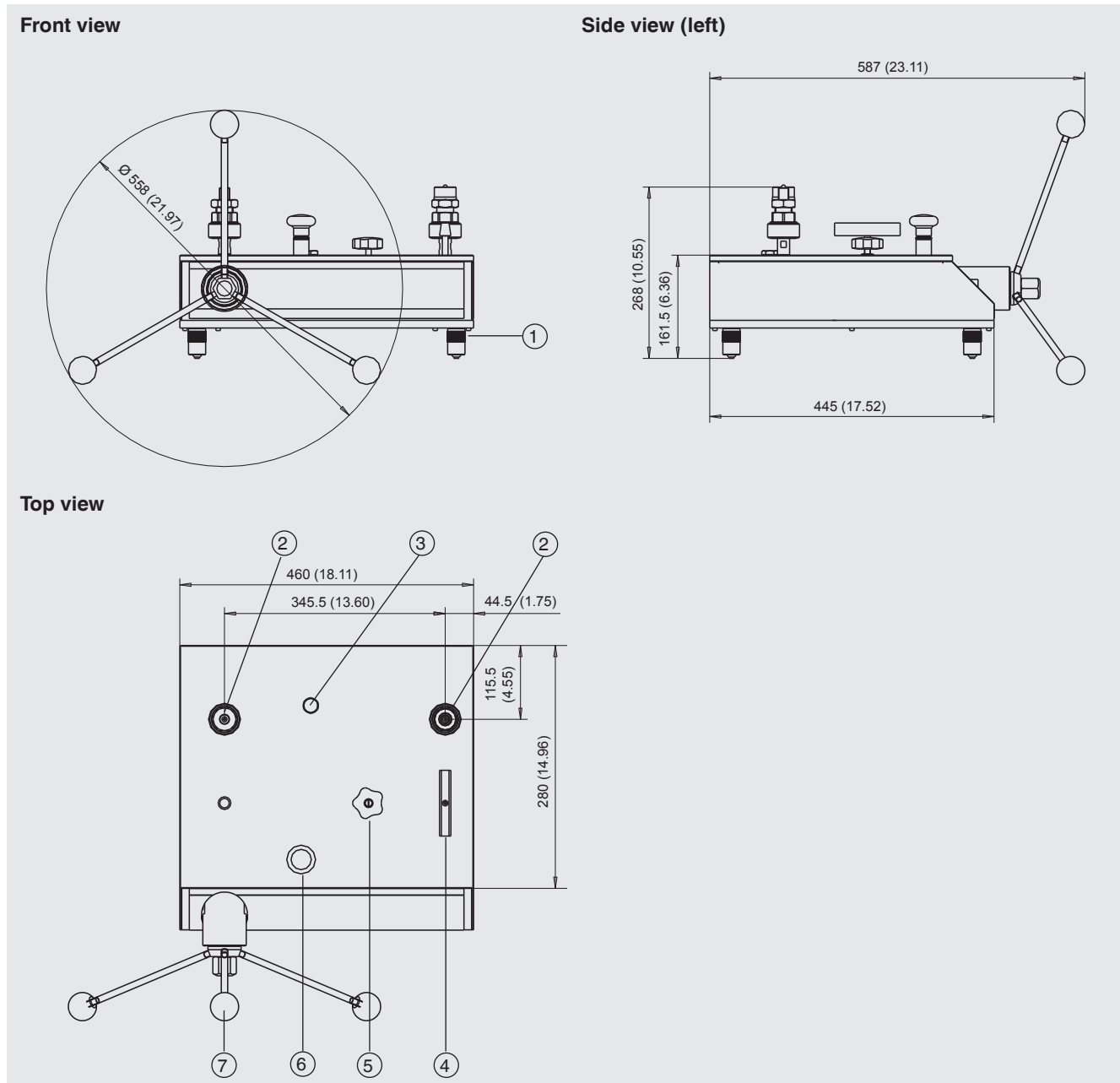

- ① Rotatable feet
- ② Test connections (knurled nut with M16 x 1.5 male thread adapter, exchangeable, freely rotating, with sealing cone)
- ③ Plug screw for medium reservoir
- ④ High-pressure shut-off valve (HP)
- ⑤ Low-pressure shut-off valve (LP)
- ⑥ Priming pump
- ⑦ Spindle pump with star handle

Recommended reference pressure measuring instruments:

Precision digital pressure gauge model CPG1000

Measuring ranges: up to 700 bar (10.000 psi)

Accuracy: 0.05 % of span

For further specifications see data sheet CT 10.01



Hand-held pressure indicator model CPH6300

Measuring ranges: up to 1,000 bar (14,500 psi)

Accuracy: 0.2 % of span

For further specifications see data sheet CT 12.01



Precision hand-held pressure indicator model CPH6400

Measuring ranges: up to 6,000 bar (85,000 psi)

Accuracy: up to 0.025 % of span

For further specifications see data sheet CT 14.01



ProcessCalibrator model CPH6000

Measuring ranges: up to 8,000 bar (115,000 psi)

Accuracy: up to 0.025 % of span

For further specifications see data sheet CT 15.01



Calibration software

WIKA-CAL calibration software for creating calibration certificates or logger protocols

For specifications see data sheet CT 95.10



Complete test and service cases with pressure generation

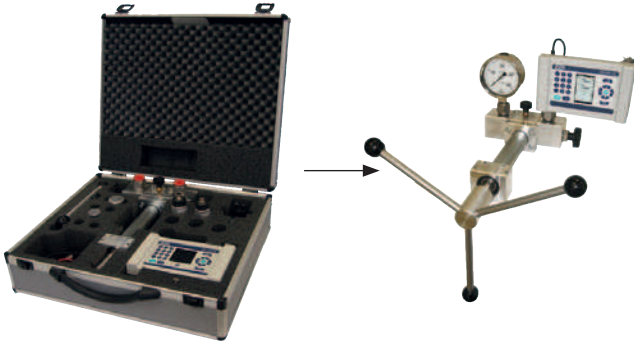

Calibration case with model CPH6000 ProcessCalibrator and model CPP1000-L hand spindle pump for pressures up to 1,000 bar (14.500 psi) consisting of:

- Transport case with model CPH6000 ProcessCalibrator
- Hydraulic hand spindle pump model CPP1000-L up to 1,000 bar (14.500 psi)
- Sensor cable for external operation of sensor
- Test cable set with connection terminals
- Charger
- Interface cable
- Sealing set
- Spaces for several CPT6000 reference pressure sensors

Basic version incl. hydraulic pressure generation

For further specifications see data sheet CT 15.01.

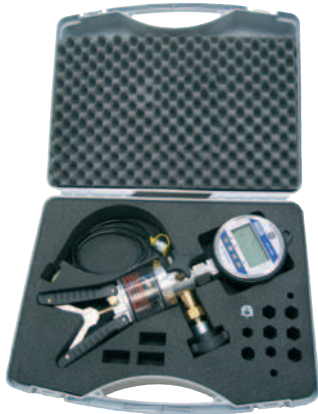

Calibration case with model CPG1000 precision digital pressure gauge and model CPP700-H hand test pump, for pressures 0 ... 700 bar (0 ... 10.000 psi), consisting of:

- Plastic service case with foam insert
- Precision digital pressure gauge model CPG1000
- Hydraulic hand test pump model CPP700-H; 0 ... 700 bar (0 ... 10.000 psi)

Basic version incl. hydraulic pressure generation

For further specifications see data sheet CT 10.01 or CT 91.07



Calibration case with model CPH6400 precision hand-held pressure indicator and model CPP30 hand test pump for pressures of -0.95 ... +35 bar (-13,8 ... +500 psi), consisting of:

- Service case with foam insert
- Precision hand-held pressure indicator model CPH6400
- Pneumatic hand test pump model CPP30, -0.95 ... +35 bar (-13,8 ... +500 psi)
- Sensor cable for external operation of sensor
- Charger
- Spaces for several CPT6400 reference pressure sensors

Basic version incl. pneumatic pressure generation

For further specifications see data sheet CT 91.06 or CT 14.01

Hand spindle pumps models CPP1000-M and CPP1000-L

Scope of delivery

- Spindle pump for filling, pressure generation and fine pressure adjustment
- Star handle
- Two test connections with G ½ female thread, loose union connection, with O-ring
- Fine adjustment valve and/or shut-off valve for model CPP1000-M as an option
- Shut-off valve for model CPP1000-L as an option (fine adjustment valve is a standard)
- Operating instructions

Accessories

Adapters

- Connection adapter, G ½ male to G ⅛ female, max. 250 bar (3,600 psi), mat.: brass
- Connection adapter, G ½ male to G ⅜ female, max. 600 bar (8,700 psi), mat.: brass
- Connection adapter, G ½ male to G ¼ female, max. 1,000 bar (14,500 psi), mat.: 1.4571
- Connection adapter, G ½ male to M20 x 1.5 female, max. 1,000 bar (14,500 psi), mat.: 1.4571
- Connection adapter, G ½ male to ¼ NPT female, max. 1,000 bar (14,500 psi), mat.: 1.4571
- Connection adapter, G ½ male to ½ NPT female, max. 1,000 bar (14,500 psi), mat.: 1.4571
- Blind plug, G ½ male, mat.: brass

Valves

- Shut-off valve for test connection, enabling the easy filling of instruments with large volumes with filling medium, directly from the hand spindle pump. Max. permissible pressure: 1,000 bar (14,500 psi). For test items and

reference instruments with a large volumes, two shut-off valves are recommended.

- Shut-off valve (recommended for connected volumes > 4 cm³), standard version
- Shut-off valve (recommended for connected volumes > 4 cm³), EPDM version
- Fine adjustment valve for retrofitting to the CPP1000-M; enables precise approach to the measuring points
 - Fine adjustment valve, standard version
 - Fine adjustment valve, EPDM version

Pressure transmission medium

- Hydraulic fluid based on VG22 mineral oil in plastic bottle, content 1 litre

Other

- Set of O-rings, consisting of 10 seals for the test connections, mat.: FKM/FPM, standard version
- Set of O-rings, consisting of 10 seals for the test connections, mat.: EPDM
- 90° angle connection for test items with back mounting connection, standard version
- 90° angle connection, for test items with back mounting connection, NBR sealing
- Replacement tank cover incl. shut-off valve, standard version
- Replacement tank cover incl. shut-off valve, EPDM version
- Replacement seal for tank cover

Tools

- Maintenance set for hydraulic hand spindle pumps, standard version
- Maintenance set for hydraulic hand spindle pumps, EPDM version

Comparison test pump of model CPP1000-X and CPP1600-X

Scope of delivery

- Priming pump for filling, spindle pump for pressure generation and fine pressure adjustment
- Two test connections with G ½ female thread, loose union connection, with O-ring
- Operating instructions

Accessories

Adapters

- Adapter set for quick-release connector in case with G ¼, G ⅜, ½ NPT, ¾ NPT and M20 x 1.5 female, mat.: stainless steel
- "NPT" adapter set for quick-release connector in case with ⅛ NPT, ¼ NPT, ⅜ NPT und ½ NPT female, mat.: stainless steel
- Adapter for connection column, G ½ male to M16 x 1.5 male with sealing cone, mat.: stainless steel

Pressure transmission medium

- Hydraulic fluid based on VG22 mineral oil in plastic bottle, content 1 litre

Other

- Set of O-rings, consisting of 10 replacement seals (8 x 2) for the test connections, mat.: NBR
- Set of O-rings, consisting of 10 replacement seals (8 x 2) for the test connections, mat.: EPDM
- 90° angle connection for test items with back mounting connection, standard version
- 90° angle connection, for test items with back mounting connection, NBR sealing
- Replacement seal set for needle valve, standard version
- Replacement seal set for needle valve, EPDM version

Tools

- Maintenance set for hydraulic volume adjuster, standard version
- Maintenance set for hydraulic volume adjuster, EPDM version
- Sealing and maintenance set for instrument base (without volume adjuster), standard version
- Sealing and maintenance set for instrument base (without volume adjuster), EPDM version

Comparison test pump model CPP7000-X

Scope of delivery

- Priming pump for filling, spindle pump for pressure generation and fine pressure adjustment
- Two test connections with M16 x 1.5 male thread, loose union connection, with sealing cone
- Operating instructions

Accessories

Adapters

- Adapter for connection column, M16 x 1.5 male with sealing cone, mat.: hardened stainless steel
- Adapter for connection column, M20 x 1.5 male with sealing cone, mat.: hardened stainless steel
- Adapter for connection column, 9/16-18 UNF male with sealing cone, mat.: hardened stainless steel
- Adapter for connection column, G ½ female with O-ring, max. 1,600 bar (23,200 psi), mat.: 1.4571

Pressure transmission medium

- Sebacate oil in plastic bottle, content 0.5 litre

Ordering information

CPP1000-M / Package / Version / Operating fluid / Left valve / Right valve / Valve mounting / Accessories / Additional ordering information

CPP1000-L / Package / Operating fluid / Left valve / Valve mounting / Accessories / Additional ordering information

CPP1000-X / Package / Medium / Adapter set / Angle connection / Accessories / Additional ordering information

CPP1600-X / Package / Medium / Adapter set / Angle connection / Accessories / Additional ordering information

CPP7000-X / Package / Additional adapter / Accessories / Additional ordering information

© 2006 WIKA Alexander Wiegand SE & Co. KG, all rights reserved.
The specifications given in this document represent the state of engineering at the time of publishing.
We reserve the right to make modifications to the specifications and materials.

