

Optoelectronic level switch

For industrial applications

Model OLS-C01

WIKA data sheet LM 31.31

Applications

- Machine tools
- Hydraulics
- Plant construction and machine building
- Pump technology
- For liquids such as oils, water, distilled water, aqueous media

Special features

- Compact design, no moving components
- Mounting position as required
- Accuracy ± 2 mm
- Visual indication of the switching status
- Choice of electrical connections: PUR, PVC cable or circular connector M8

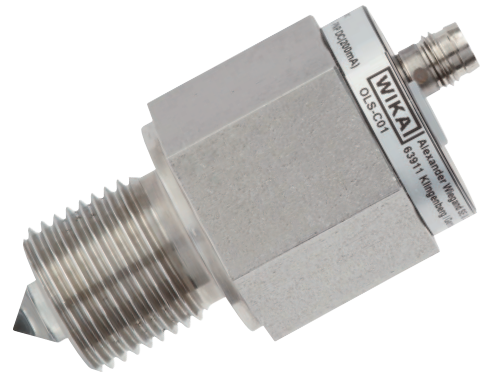

Optoelectronic OEM level switch, model OLS-C01, with circular connector M8

Description

The model OLS-C01 optoelectronic OEM level switch is used for monitoring the level of liquids. The optoelectronic sensor consists of an infrared LED and a light receptor.

The light from the LED is directed at a prism which forms the tip of the sensor. So long as the tip is not immersed in liquid, the light is reflected within the prism to the receiver.

When the liquid rises within the vessel and surrounds the tip, the light beam is refracted by the liquid, so that the receiver is no longer or only weakly reached by the light and reacts to this change by triggering a switching operation.

The switching status can be read directly on the sensor (yellow LED).

Specifications

General data	
Measurement accuracy	±2 mm
Minimum distance from the glass tip to an opposite surface	≥ 10 mm ≥ 20 mm with electropolished surface
Mounting position	as required
Visual indication of the switching status	1 LED
Process connection G	G 3/8", G 1/2" or M12 x 1 (male)

Design data	
Responsiveness	Preset for the detection of aqueous media and oils Option: Adjustable responsiveness (trimmer) for other liquids and foaming media
Medium temperature	-30 ... +100 °C
Ambient temperature	-25 ... +70 °C
Operating pressure	0 ... 2.5 MPa (0 ... 25 bar)
Materials	
■ Light guide	Borosilicate glass, fixed with silicone adhesive (Option: Fixed with epoxy resin)
■ Case and process connection G 3/8" and M12 x 1	Stainless steel 1.4305
■ Case and process connection G 1/2"	Stainless steel 1.4571

Electrical data	
Power supply	DC 12 ... 32 V
Max. current supply	40 mA
Electrical connection	
■ PUR, PVC cable	Cable length freely definable Diameter: 3 x 0.25 mm ² Cable end: Cut to length
■ Circular connector	M8 x 1 (3-pin)
Output signal	PNP transistor, protected against reverse polarity, 200 mA switching current
Switching function	Normally open (closed in medium) or normally closed (open in medium)
Ingress protection	IP65
Number of switch points	1

Switching delay of up to 7 s on request

Options

- Other versions on request

Dimensions in mm

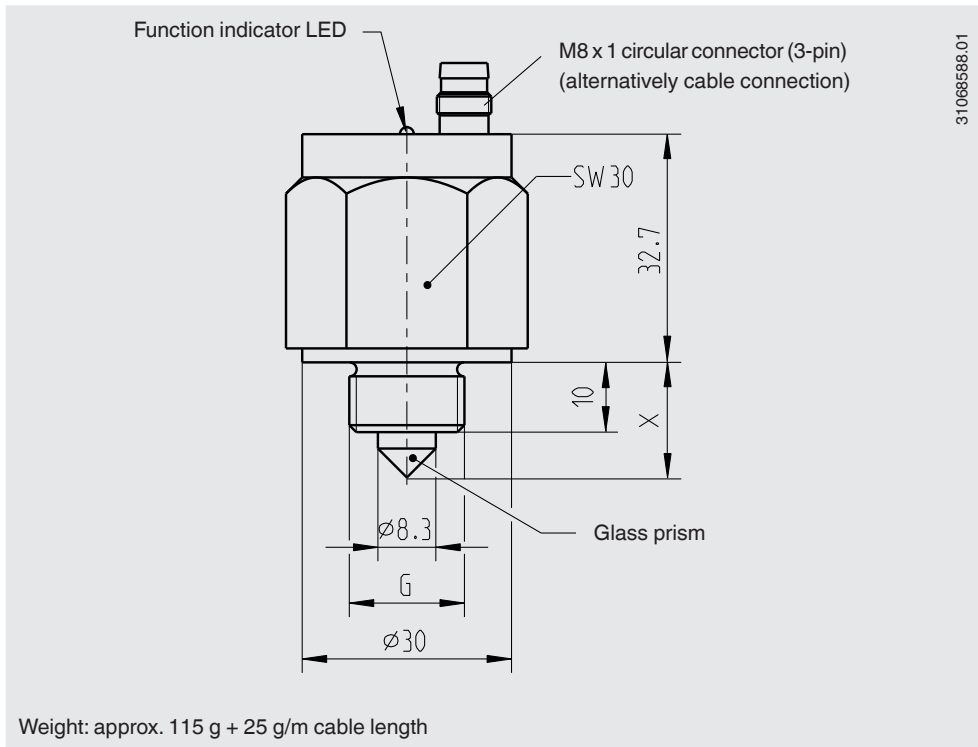



Process connection G	X
G 3/8"	17 mm
M12 x 1	17 mm
G 1/2"	27 mm

Electrical connection diagram

Cable assignment		
	BN	U ₊
	WN	U ₋
	GN	SP

Assignment, M8 x 1 circular connector		
	1	U ₊
	3	U ₋
	4	SP

Accessories

Description	Order no.
M8 connector with moulded cable	
 Straight version, cut to length, 3-pin, 2 m (6.6 ft), PUR cable, UL listed, IP67	14159311
	14159313
 Angled version, cut to length, 3-pin, 2 m (6.6 ft), PUR cable, UL listed, IP67	14159309
	14159310

Approvals

Logo	Description	Country
	EU declaration of conformity <ul style="list-style-type: none"> ■ EMC directive EN 61326 emission (group 1, class B) and interference immunity (industrial application) ■ RoHS directive 	European Union

Manufacturer's information and certificates

Logo	Description
-	China RoHS directive

Approvals and certificates, see website

Ordering information

Model / Process connection / Electrical connection / Switching function / Cable length / Options

© 08/2014 WIKA Alexander Wiegand SE & Co. KG, all rights reserved.
The specifications given in this document represent the state of engineering at the time of publishing.
We reserve the right to make modifications to the specifications and materials.

