

Gas density transmitter

Model GD10-L, with angular connector

Model GD10-C, with cable connection

WIKA data sheet SP 60.11

Applications

- Gas density monitoring of closed SF₆ tanks
- For indoor and outdoor installation in SF₆-gas-insulated switchgear

Special features

- Measuring ranges from 0 ... 10 to 0 ... 80 g/litre
- Output signal 4 ... 20 mA, 2-wire
- Wetted parts and case made of stainless steel, fully welded
- Ingress protection IP 54 up to 68, depending on the electrical wiring
- Excellent long-term stability, high EMI performance

Description

The gas density transmitter is electronically compensated. The compensation follows the nonlinear behavior of SF₆ gas. The basic principle is the calculation following virial equation. The gas density transmitter picks up the physical variables pressure and temperature of the SF₆ gas contained in the device (tank). The current gas density is ascertained from both variables by means of an electronic evaluation system. Thermal induced pressure changes are dynamically compensated and do not affect the output signal.

The gas density transmitter generates a density proportional, standardized signal of 4 ... 20 mA.

A recalibration of the zero signal as well as maintenance service will no longer be necessary due to the high long-term stability of the gas density transmitter.



Gas density transmitter

Fig. left: with angular connector, model GD10-L
Fig. right: with cable connection, model GD10-C

As a standard, wetted parts are made of stainless steel. The hermetically welded measuring cell guarantees high long-term tightness. The specific structure of the measuring cell requires absolutely no internal sealing elements so that any leakage of the instruments can be excluded. Due to these features the gas density transmitter is also independent of atmospheric pressure fluctuations and variations of the mounting height.

The EMI properties of the transmitter are tested according to industrial standards (see page 3) and guarantee a safe pick-up of the signal which is especially suited to conditions prevailing in high-voltage switching units.

Dimensions in mm

Electrical connection

2-pin angular connector (model GD10-L)

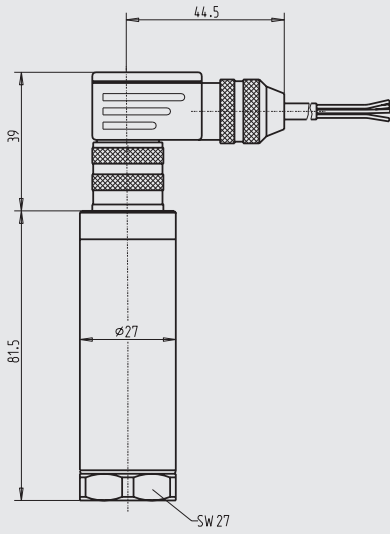

with flying leads (model GD10-C)

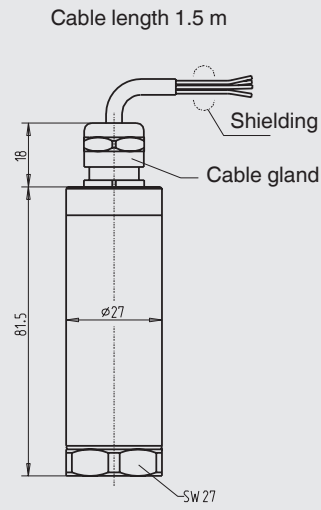

Process connection, socket

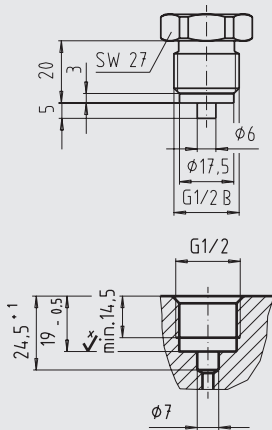

Wiring details

2-wire connection

2-pin angular connector (model GD10-L)

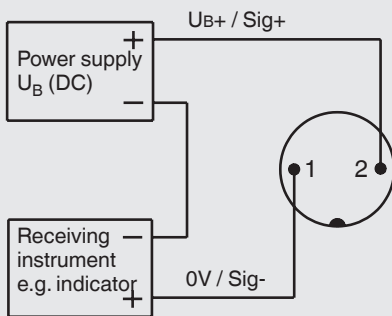

with flying leads (model GD10-C)

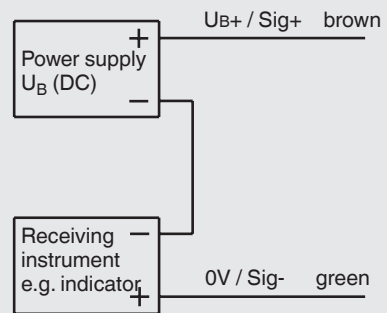

Specifications

Specifications, model GD10-L, model GD10-C							
Density ranges	g/Litre	10	16	25	40	60	80
(Pressure ranges related to 20 °C)	(bar abs.)	(1.64)	(2.59)	(3.97)	(6.16)	(8.87)	(11.33)
Over pressure safety	bar abs.	14	14	14	29	29	67
Burst pressure of sensor	bar abs.	17	17	17	35	35	80
Designed for sensing		pure SF ₆ gas					
Principle		piezoresistive					
Pressure reference		absolute pressure					
Process connection		G ½ B male (other connections on request)					
Materials							
■ Wetted parts		stainless steel					
■ Case / terminal case		stainless steel					
Internal transmitting fluid		synthetic oil					
Power supply U _B		DC 10 ... 30 V					
Signal output and maximum load R _A		4 ... 20 mA, 2-wire, R _A ≤ (U _B - 10 V) / 0.02 A with R _A in Ohm and U _B in Volt					
Accuracy		-40 °C: 3 % of span, 20 °C: 1 % of span, 60 °C.: 2.3 % of span (optimal accuracy point)					
		-40 °C: 4 % of span, 20 °C: 2 % of span, 60 °C: 3.3 % of span (beginning and end of measuring range)					
1-year stability		≤ 0.3 % of span (at reference conditions)					
Permissible ambient temperature							
■ Nominal temperature		-40 ... +60 °C (-40 ... +140 °F) [gas phase!]					
■ Storage temperature		-40 ... +80 °C (-40 ... +176 °F)					
CE conformity		EN 61326-1					
EMC directive		2004/108/EC, EN 61326 Emission (Group 1, Class B) and Immunity (industrial locations)					
High voltage strength		DC 750 V (wiring versus case)					
Electro-magnetic immunity (EMI) / RFI per IEC 61000-4		IEC 61000-4-2 (ESD): test level 4 (8 kV) IEC 61000-4-3 (Field): test level 3 (10 V/m) IEC 61000-4-4 (Burst): test level X (±2 kV) IEC 61000-4-5 (Surge): test level 2 (±1 kV) IEC 61000-4-6 (Conducted RFI): test level 3 (10 V)					
Cable gland and ingress protection per EN 60529 / IEC 529		Model GD10-L: 2-pin plug, IP 67 {L-junction box brass, nickel-plated, IP 67} Model GD10-C: cable gland with flying lead 1.5 m; IP 68					
Wiring protection		protected against reverse polarity and overvoltage					
Weight		max. 0.5 kg					
Dimensions		see drawing					

Items in curved brackets { } are optional extras for additional price.

Ordering information

Model / Density range / Process connection / Options

© 2010 WIKA Alexander Wiegand SE & Co. KG, all rights reserved.
The specifications given in this document represent the state of engineering at the time of publishing.
We reserve the right to make modifications to the specifications and materials.

