

The new K Series.

High-capacity bead mills with conical slot agitator.



The new K Series.

Perfection through continuous innovation.

K Series – perfected bead mill for applications ranging from laboratories to large-scale production. The tried and trusted K Series enjoys an outstanding reputation in a wide variety of industries where wet grinding and dispersing processes are of central importance.

The steady increase in requirements for existing and new technologies has propelled the further development of the

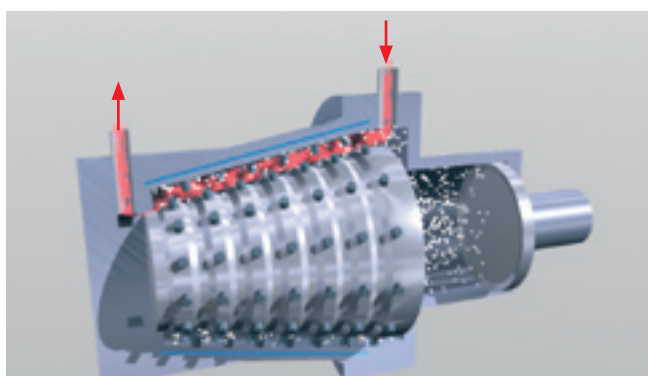

K Series. Knowledge gained from intensive research and productive applications at the sites of our demanding customers has been continuously and systematically transformed into practical innovations and has been incorporated into the machine design. For example, the average life cycle of the K240 in the large-scale production of highly abrasive carbon black based pigment dispersions has been multiplied!

The heart of the K design is its conical slot agitator with the dynamic grinding gap relief feature and intensive stator and rotor cooling system. It allows the processing of products across a wide viscosity range and offers high flexibility in terms of grinding formulation quality.

The processing zones of stainless steel and ceramic materials, which has been optimized on the basis of experience, maximize life cycles while minimizing the maintenance requirements.

In the machines equipped with a PLC control system, the control of important process parameters allows fully automatic operation. Process data registration ensures perfect documentation.

Printing inks and concentrates

Medium- to high-viscosity products with solids contents up to 70%. Maximum throughput rates with excellent cooling characteristics and life cycles.



High-viscosity pastes

Thanks to the dynamic relief of the separating slot and the conical processing zone, K Technology is excellently suited to dealing with extremely high viscosities.



Pastes for the electronics industry

Ceramic processing zones of SiC or ZrO₂ ensure contamination-free wet grinding and dispersion processes as well as excellent cooling characteristics (SiC).



Cosmetics and pharmaceuticals

Integrated, fully automatic production systems made of stainless steel satisfy the most rigorous requirements in terms of sanitation and cleaning (SIP/CIP).



The series.

Highlights from lab to production scale.

K8

For laboratory and research applications and for small-scale production. Flexible desk-top unit, installed within a short time and easy to operate.

- Process data registration and trending
- Ceramic design of ZrO_2 and SiC for contamination-free processes
- Frequency converter for controlled grinding media pressure



K60

The K60 is considered the most universal bead mill currently available in the marketplace, especially for batch sizes starting at 50 kg.

- Ceramic design of SiC for contamination-free processes
- Optimized agitator geometry for maximum cooling action and long life cycle
- Stainless steel version, Cleaning and Sanitation in place
- Frequency converter for controlled grinding media pressure (option)



K120

High-capacity bead mill for top throughput rates and batch sizes starting at 100 kg.

- Optimized agitator geometry for maximum cooling action and long life cycle
- Siemens S7 PLC with graphic user interface and touch-screen
- Frequency converter for controlled grinding media pressure (option)



K240

Tailor-made bead mill for integration in high-capacity production systems or for batch sizes starting at 200 kg.

- Bead mill geometry optimized on the basis of experience for handling highly abrasive materials
- Unsurpassed life cycle in the processing of carbon black based pigment dispersions
- Frequency converter for controlled grinding media pressure (option)



Technical data.

The K Series	K8	K60	K120	K240
Grinding volumes	0.5 l	5 l	10 l	20 l
Installed motor power	4 kW	24–30 kW	45–55 kW	90 kW
Throughput	10%	100%	200%	400%
Application	Laboratory	Universal	Average batches	Large-scale production

Outstanding scale-up characteristics from laboratory mill to high-capacity production machine.

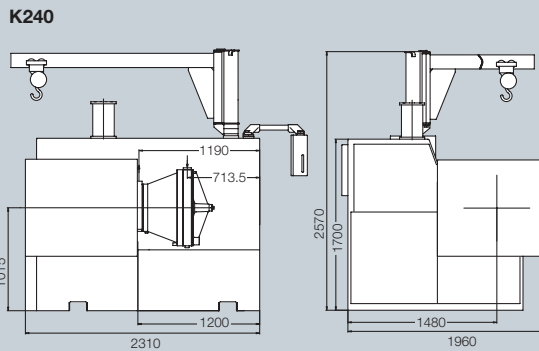
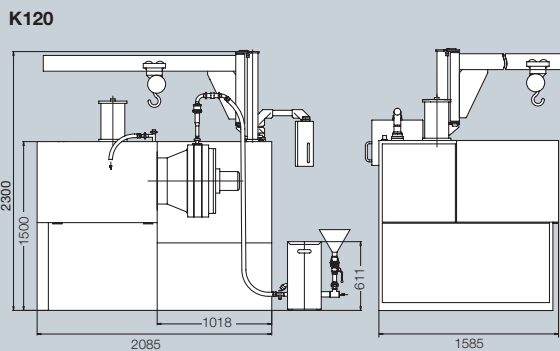
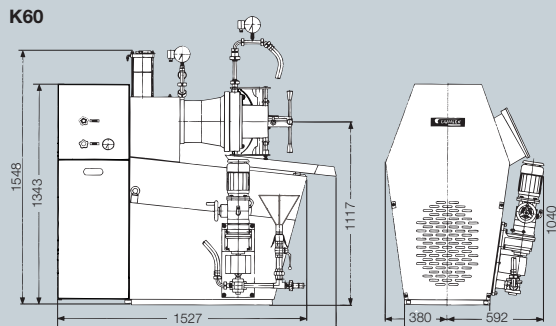
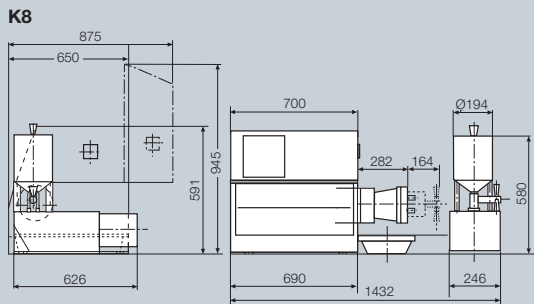

Technical data, weights, etc.

Type	K8	K60	K120	K240
Cooling water usage at 3 bar, m ³ /h	0.9	1.8	4.5	4.5
Control air pressure in bar	6–10	6–10	6–10	6–10
Product flow rate in dm ³ /h	0.5–30	8–400	40–800	60–1200
Grinding media Ø in mm	0.3–2.5	0.4–2.5	0.6–2.5	1.6–2.5
Unpacked (weight in kg)	200	1050	2500	4185
Rail-packed (weight in kg)	220	1180	2650	4490
Sea-packed (weight in kg)	250	1300	3000	4980
Volume of seaworthy packing in m ³	1.5	4.6	11	18.7

Equipment concept

	K8	K60	K120	K240
S = Standard version	K8	K60	K120	K240
O = Optional equipment				
Intensive rotor/stator cooling	S	S	S	S
Separating ring cooling	–	S	S	S
Double-acting mechanical seal	S	S	S	S
High-precision slot separator	S	S	S	S
Separating ring reusable several times	S	S	S	S
Stopping via product pressure	S	S	S	S
Stopping via product temperature	S	S	S	S
Handling unit	–	–	O	O
Material pump	O	O	O	O
Cleaning unit	–	O	O	O
Explosion-proofed version	O	O	O	O
Frequency converter	S	O	O	O
SiC ceramic agitator	O	O	–	–
ZrO ₂ ceramic agitator	O	–	–	–

Flexibility in plant design. Fully automatic processes using K Technology.

K Technology is distinguished by its high flexibility in processing different grinding formulations:

- Unsurpassed life cycle in processing highly abrasive products
- Constant output quality with variable premixes
- Wide viscosity range

These characteristics allow a high degree of freedom in the design of high-capacity production systems.

At the sites of leading manufacturers of all types of printing ink, the K240 in combination with Buhler three-roll mills form the heart of the production system and therefore enjoy a leading market position.



Fully automatic offset line. Throughput 1000 kg/h.

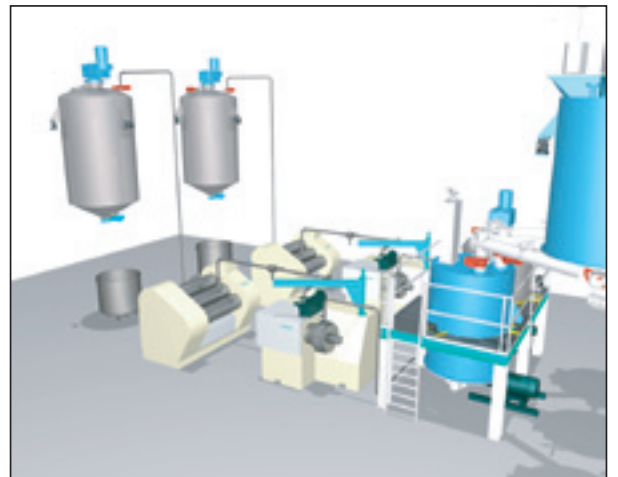

System engineering using state-of-the-art planning tools.



Cosmetics: Top cleaning and sanitation requirements.
Cleaning and sanitation in place – CIP/SIP.

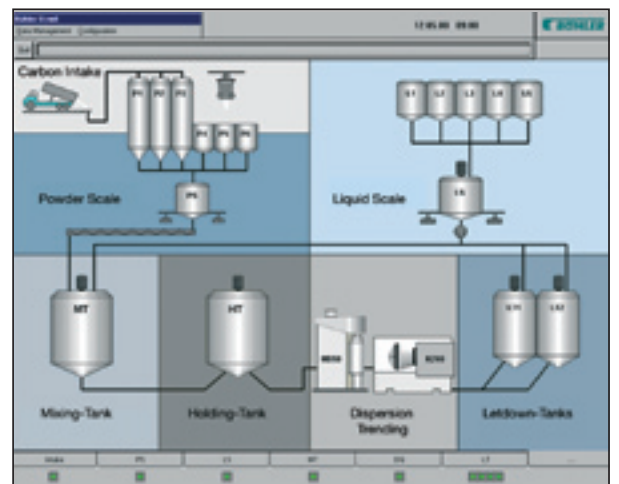

Process control system with visualized process monitoring.

Bühler AG
CH-9240 Uzwil, Switzerland
T +41 71 955 34 91
F +41 71 955 31 49
E-Mail: grinding.dispersion@buhlergroup.com
www.buhlergroup.com

