

Bornemann pumps and systems for tank storage, -terminals and refineries

For the efficient and economic
storage and transport of mineral oil products

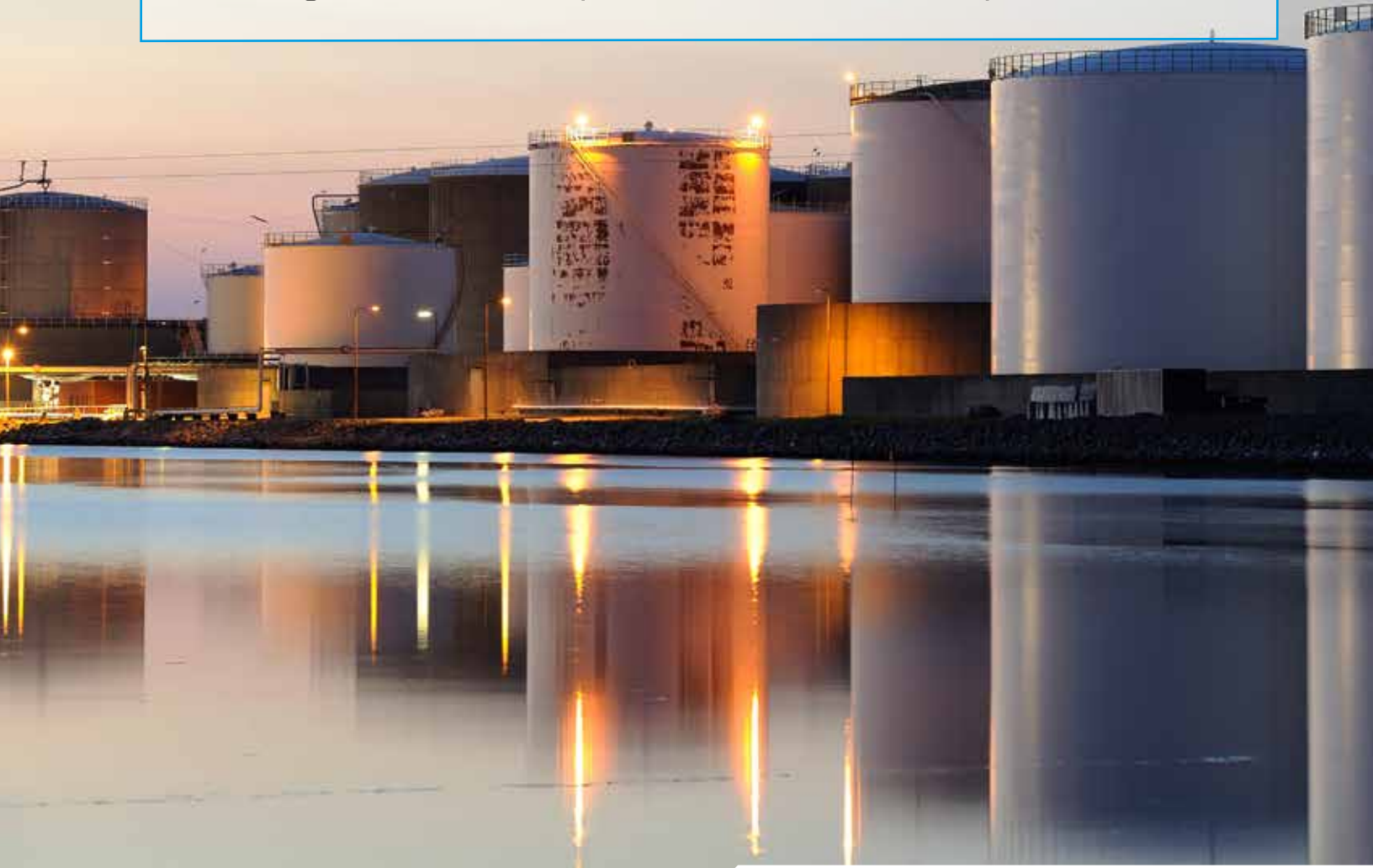

Our expertise for tank storage and -terminals and refineries



Reliable performance, day by day

Application advantages

- Loading and unloading with wide range of capacity
- Circulation from tank to tank
- Stripping of tank and pipes
- Operation with wide range of product viscosity
- Operation at high or low pressure
- Full Control in all kind of operation modes
- Reduced installation costs for pipes and valves
- High safety due to variable operation
- Low Pulsation
- No fixed duty points

Bornemann twin screw pumps prove their worth in pumping applications of all kinds throughout the world, which must perform under extreme environmental conditions.

Their advantages are operational safety, reliability and consistent performance, long life and low operating costs.

Bornemann twin screw pumps are rotary positive displacement pumps; the gearwheels and roller bearings are externally mounted and never come in contact with the pumped media.

Around 80 models are available, in various materials, sizes and forms, providing application-optimized solutions.

Bornemann twin screw pumps are double-flow and self priming. There is no metal-to-metal contact between the pump screws and the housing.

As the pumping elements rotate, the intermeshing of the two screws along with the pump housing form chambers. These chambers fill with the pumped fluid and transfer it from the suction side to the higher pressure discharge side of the pump.

The pump is designed to allow for reverse flow by simply changing the shaft direction. The suction becomes the discharge and vice versa, all without any modifications to the pump.

Tank Farms and Tank Terminals are usually situated close to oil refineries or in locations where marine tankers containing products can discharge their cargo. Some depots are attached to pipelines from which they draw their supplies.

Bornemann pumps have a wide field of application in tank farms and terminals. They can be employed at all

places where a high suction capability is required. Loading and unloading of ships, rail tankers, road tankers and conveying into storage tanks is just as possible as extraction from tanks, even with high viscosity and long pipes.

A refinery performs three basic steps: separation, conversion and treatment. Each function in the refining process is designed to maximize the value of the

refined petroleum products produced.

Refineries run twenty-four hours a day. Bornemann twin screw pumps are the ideal solution for transfer within terminals where both low and high viscosity products have to be moved or metered. Product applications: mazut, bitumen, tar, heavy fuel and light products.





W/V universal pump
8 models up to 2,800 m³/h



HC/VHC high capacity pump
6 models up to 4,500 m³/h



HP high pressure pump
4 models up to 800 m³/h



SLI compact pump
3 models up to 180 m³/h

	Capacity		Differential pressure		Viscosity mm ² /s cSt	Max. Product Temperature	
	m ³ /h	gpm	bar	psi		°C	°F
W/V universal pump	10 - 2,800	50 - 12,300	up to 40/60	up to 600/900	0,5 - 200,000	up to 350	up to 660
HC/VHC high capacity pump	up to 4,500	up to 19,800	up to 16	up to 230	1 - 20,000	up to 120	up to 250
HP high pressure pump	20 - 800	100 - 3,500	up to 100	up to 1,500	1 - 10,000	up to 120	up to 250
SLI Compact pump	up to 180	up to 790	up to 16	up to 230	up to 100,000	up to 120	up to 250

Technological competence and extensive flexibility

- Bornemann twin screw pumps are self priming
- Twin screw pumps are ideally suited for low and high viscous media
- Overall efficiency with different working points
- Compact design ensures space-saving set-up
- Functional principle ensures low-pulsation and low-noise operation
- Short-term dry run operation possible
- High suction lift up to 8,5 m (25 feet)
- Constant flow at varying pressures and volumes
- Intensive research and development to increase efficiency and profitability
- In conformity with ATEX 94/9/EG, API 676 and the German TA Luft 2002

Positive displacement pumps

- Create constant flow. Volume is moved from suction to discharge side
- Without discharge pipe the liquid would exit at atmospheric pressure
- Suitable for applications where a constant flow is required also handling at variable system pressure
- Speed/capacity range 1:10

Centrifugal pumps

- Create constant pressure, in accordance with the pump curve
- Kinetic energy is transformed into pressure
- Without discharge pipe the liquid would exit at this developed pressure
- Limited flexibility in variable operation
- Fixed working points*
- Sensible for viscosity/density

Performance Curve Twin Srew Pumps - Centrifugal Pumps by Change of Viscosity

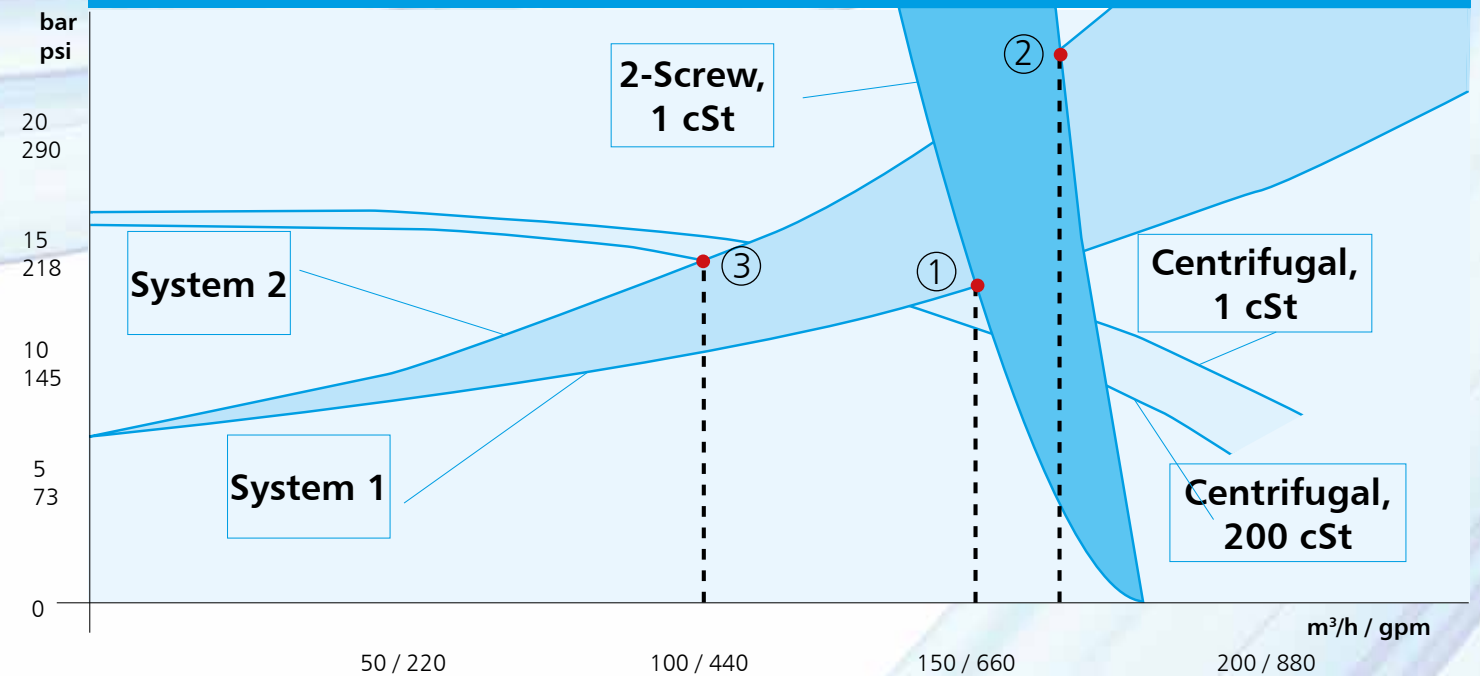

1 - Basis for centrifugal and screw pump 1 cSt (system 1)
 The change of viscosity occurs a new system performance curve (system 2)
 2,3 - The new performance curve shows the capacity decrease for centrifugal pumps and the capacity increase for screw pumps.
 The higher the viscosity the higher the capacity (applicable for Twin Screw Pumps)

* duty point will vary with changing pressure, throttle valve necessary

Higher flexibility of operation with one installation and control system only



Pump I
1500 m³/h @ 100 mlc,
max. 150 cSt / VLCC



Pump II
1000 m³/h @ 100 mlc,
max. 150 cSt / Barges



Pump III
150 m³/h @ 100 mlc,
max. 150 cSt / Railcars



Is one pump able to handle all applications?

One for all

Advantages

- High flow rate
- Casted pump casing
- High efficiency up to 80 %
- Handling of wide ranges of viscosities and differential pressures with one pump
- Self priming and excellent NPSH value
- Large capacity control by speed variation control
- Wide range of screw pitch sizes per model
- Smooth and low pulsation hand-ling of the product (very little shear forces transported into the liquid)

HC or W Type



Twin Screw Pump with Control System
Capacity range:
50m³/h - 4500 m³/h
Viscosity range:
0.5 cSt - 2500 cSt
Compact design

VLCC



Barges



Railcars



Control and protection by control system

General features

- Safe design for human and environment
 - independent operating ESD system
 - pump protection system
 - pump control system
- Design in accordance with European or American Standards
- Ready for operation in hazardous area
- Standard components in use
- Pre-tested operational system with FAT at the Bornemann workshop
- ATEX Zone I

Electrical design

- Completely engineered system
- KIS-operation (Keep-It-Simple)
 - Human Machine Interface (HMI) in the control room
 - Local control panel on skid
 - HMI on the skid (if requested)
- All necessary pump protection procedures programmed
- Manual and automatic pump operation procedures
- The control system is ready to communicate to a station control system by Profibus, Modbus, Device-net or Ethernet



Above: Operation by Local control panel
Below: KIS Operation

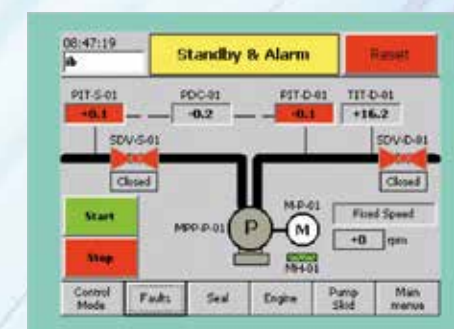

HC Pump - with an excellent rate of performance to size/weight

A key design feature of Bornemann Twin Screw Pump Type HC/VHC is their unique screw geometry.

These deep-chamber screws allow for an optimum diameter/length ratio, ensuring deflection-free performance and maximum output capacity.

Bornemann twin screw pumps are the ideal solution for transfer within terminals where both low and high viscosity products have to be moved or metered. All fluids whether neutral, alkaline or acid and aggressive, abrasive or gaseous are sucked up safely, dosed and pumped.

Due to Bornemann's unique design of separately manufactured shafts and screws, many different material combinations are available.

Many benefits speak for themselves

- Wide range of performance
- Optimum diameter / length ratio
- High pressure ratings
- Flow rate is increased by up to 30%*
- Total efficiency is improved by up to 15%*
- Suction lift capacity is increased by up to 8,5 m* (27,8 feet)
- Pump weight is reduced by up to 35%*
- Space savings of up to 30%*
- Pumps can be mounted vertically or horizontally
- Low price
- Capacity up to 4500 m³/h
- Cast housing
- Standardization

*Compared to the standard



More Power - Sustained Performance up to 4500 m³/h

This two-piece design also allows the screws and shafts to be replaced independently of one another, maximizing interchange ability while reducing maintenance cost and downtime.

The optional relief valve is designed to ensure a quick response and minimum pressure increase upon opening.

All relief valves are designed for 100 % of the rated capacity.

The HC/VHC pump's axial bearings are a rugged dual angular ball-bearing style that ensures reliable performance under high axial load conditions. The bearings and timing gears are lubricated in an oil bath. A specially developed gear adjustment mechanism makes service much easier by eliminating the need for gear re-adjustment during maintenance of the pump.



Capacity for HC-series

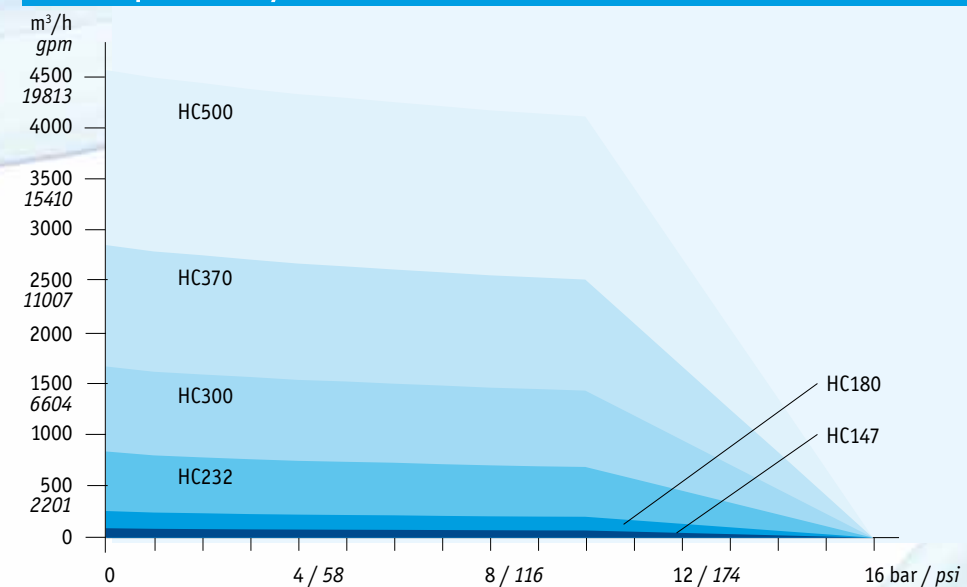

Material Execution

- Nodular cast iron (GGG-40.3)
- Cast steel (GS-C 25)

Mechanical seals

- M7N 90 (standard)
- EN 12756

Performance Data

- Screw diameter up to Ø 465 mm
- Max. suction pressure 10 bar
- Max. discharge pressure 16 bar
- Max. differential pressure 16 bar
- Speed range 200 – 1500 min⁻¹
- Viscosity range 1 – 20.000 cSt
- Operating temperature up to 120 °C
- Flow rate 100 – 4500 m³/h
- Oil lubrication drive end
- Heating food (optional)

Tank storage plant equipped with Bornemann pumps

A flexible Terminal facility for the storage and handling of petroleum products, chemicals and heavy products requires high capacity pumps.

Bornemann Pumps will assure a reliable performance and a quick turn around.

Applications

- Loading and unloading of barges and tankers via jetties
- Loading and unloading of tank trucks or rail cars
- Tank to tank circulation
- Transfer
- Stripping

In dedicated installations to handle only one tank or in multi-connected installations to serve several tanks.

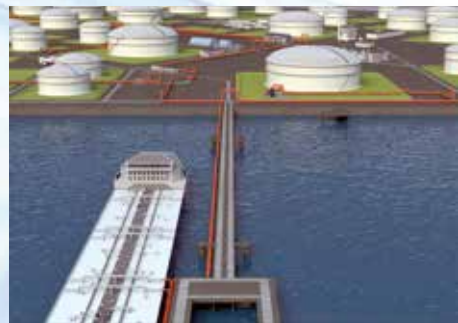

Loading and unloading of barges and tankers via jetties



Dedicated and multi-connected installation

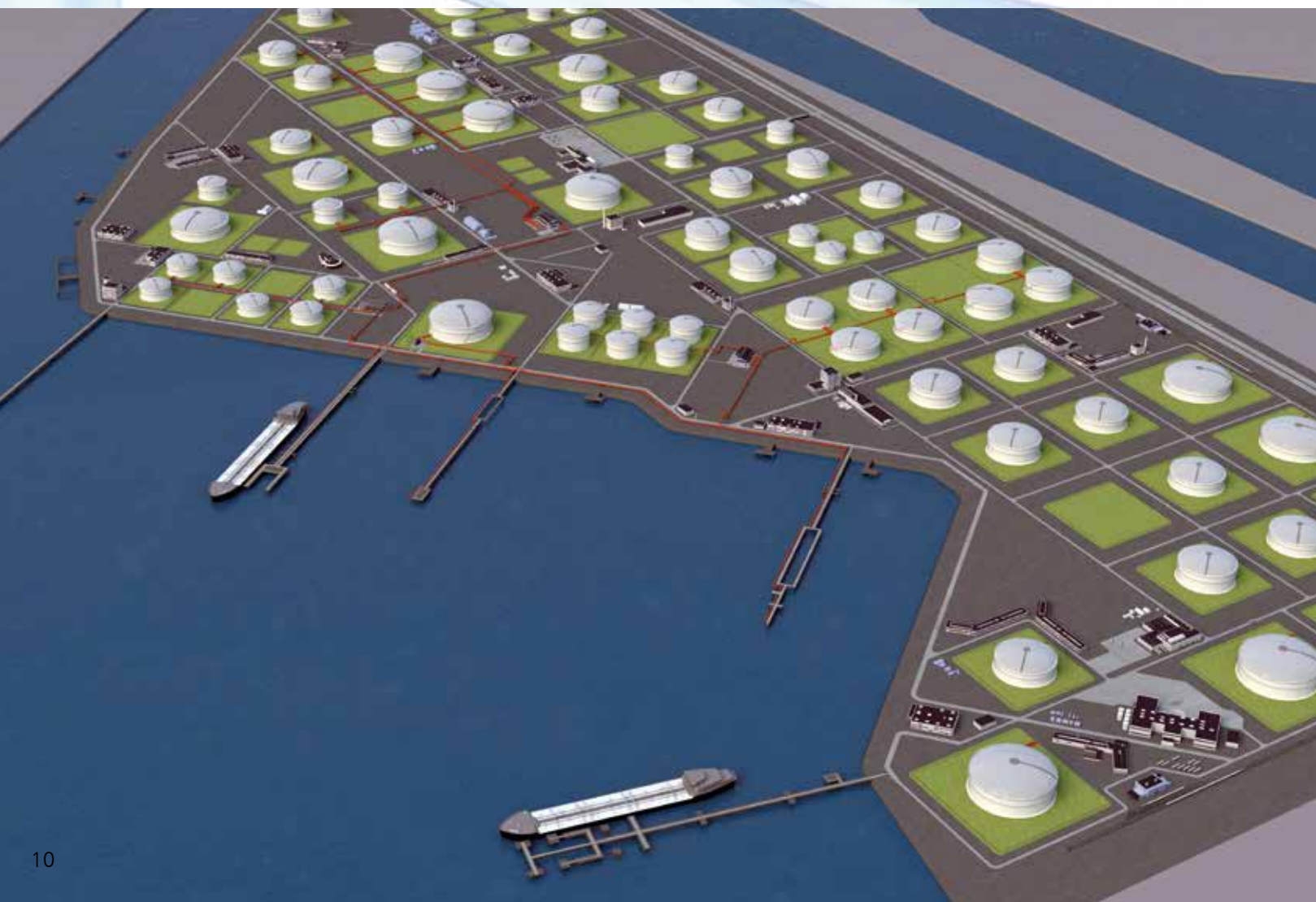

Applications in oil terminals and tank farms for the professional and economic Storage

Installation of HC 370 incl. Control System, The Netherlands

Pump type HC 370
 Liquid Diesel Oil, Naphta
 Pressure 1 - 10 bar (15 - 150 psi)
 Capacity 150 - 1,500 m³/h (660 - 6,600 gpm)



Russia
 Pump type W8.5zk
 Heating jackets
 Capacity 1000 m³/h (4400 gpm)
 Pressure 8 bar (116 psi)



Argentina

Pump type HP 255
 Capacity 248 m³/h (1100 gpm)
 Pressure 39 bar (570 psi)



The Netherlands

Pump type W9.6zk
 Capacity 800 m³/h (3500 gpm)
 Pressure 7 bar (100 psi)



Singapore

Pump type W7.2z
 Capacity 200 m³/h (880 gpm)
 Pressure 8 bar (116 psi)



China

Pump type HC 232
 Capacity 200-600 m³/h (-2600gpm)
 Pressure 8 bar (116 psi)



The Netherlands

Pump type W9.6zk
 Capacity 1500 m³/h (5300 gpm)
 Pressure 10 bar (150 psi)
 Fuel oil 850 cSt - 50 °C
 Gasoil 10 cSt



Middle East

Pump type W9.5zk
 Capacity 1400 m³/h (6200 gpm)
 Pressure 12 bar (175 psi)



Unique solutions made by the specialist



ITT Bornemann GmbH

Industriestraße 2
31683 Obernkirchen
Germany
Fon: +49 5724 390-0
Fax: +49 5724 390-290
info@bornemann.com
www.bornemann.com



Germany – Headquarter

Canada

Bornemann Inc.

320 441, 5th Avenue S.W.
Calgary, Alberta
Canada T2P 2V1
CANADA
Fon: +1 403 294 0777
Fax: +1 403 262 4073
info.ca@bornemann.com
www.bornemann-ca.com

USA

ITT Bornemann USA, Inc.

10375 Richmond Avenue,
Suite 1575
TX 77042 Houston
UNITED STATES OF AMERICA
Fon: +1 832 320 2500
info.usa@bornemann.com
www.bornemann-usa.com

Argentina

Bombas Bornemann S.R.L.

Mariano Moreno 4380
B1605BOD Munro
Prov. Buenos Aires
ARGENTINA
Fon: +54 11 475 680 08
Fax: +54 11 475 655 41
info.ar@bornemann.com
www.bornemann-ar.com

Mexico

Bornemann S.A. de C.V.

Mariano Escobedo 510 piso 12 y PH 33
11590 Col. Anzures, Distrito Federal
MEXICO
Fon: +52 55 2000 0589
info.mx@bornemann.com
www.bornemann-mx.com

Singapore

Bornemann Pumps Asia Pte. Ltd.

10 Jalan Kilang #06-01 Sime Darby
Enterprise Centre
159410 Singapore
SINGAPORE
Fon: +65 6561 4882
Fax: +65 6561 6784
info.sg@bornemann.com
www.bornemann-sg.com

China

Bornemann Pumps & Systems (Tianjin) Co., Ltd.

Jinbin General Building No. 6,
No. 45 Muning Road
TEDA, Tianjin
P. R. China 300457
CHINA
Fon: +86 22 662 978 00
Fax: +86 22 253 267 99
info.service@bornemann-cn.com
www.bornemann-cn.com

Bornemann Pumps International Tianjin

Room 1101
Tianjin Binjiang International Hotel
No. 105 Jianshe Road
Heping District, Tianjin
CHINA
Fon: +86 22 5881 2997
Fax: +86 22 5881 2996
info.sales@bornemann-cn.com
www.bornemann-cn.com

UAE

Bornemann Middle East FZE

Dubai Airport Freezone
Office 530 / 6WA West Wing
PO Box 293 582
Dubai
UNITED ARAB EMIRATES
Fon: +971 4 214 6511
Fax: +971 4 214 6512
info.ae@bornemann.com
www.bornemann-ae.com