

Contents

Introduction p. 398

Choosing a system p. 400

Modular system p. 404

Modular profiles p. 416

Accessories p. 428

Fax enquiry p. 448

Protection and partitioning system

Protection and partitioning system

Introduction

Due to the ever increasing automation of manufacturing processes and equipment, the protection of people from sources of danger is growing in importance.

The safety guard has a grid design and therefore reduces the effort required from the user in planning, construction and assembly to a minimum.

It complies with the new Machinery Directive 2006/42/EC.

A modern connector that meets the legal requirements for safety devices safely fixes post and safety guard element. Posts and safety guard elements come with all attachments on delivery, so safety guard elements can be installed without tools. After the posts are secured to the substrate, the safety guard elements need only be inserted at the bottom and pressed in at the top – done!



<p>Introduction</p>	<ul style="list-style-type: none"> ■ Choosing a system p. 400 ■ Safety distances p. 402 	<p>Introduction</p>
<p>Modular system</p>	<ul style="list-style-type: none"> ■ Function/Planning/Requirements..... p. 404 ■ Pillar p. 406 ■ Pillar profiles p. 408 ■ Supporting/Levelling shims p. 408 ■ Panels p. 409 ■ Hinged door p. 412 ■ Double-wing hinged door p. 413 ■ Sliding door p. 414 ■ Lifting door p. 415 ■ Modular profiles p. 416 	<p>Selection guide</p> <p>Structural profiles</p>
<p>Accessories</p>	<ul style="list-style-type: none"> ■ Base clamp from p. 428 ■ Fasteners from p. 429 ■ Support from p. 429 ■ Corner joint from p. 430 ■ Connection element -S- (Click & Safe) from p. 432 ■ Bracing plate from p. 434 ■ Cover profile from p. 434 ■ Profile seal from p. 435 ■ Door gap seal from p. 435 ■ Rim from p. 435 ■ Hinges from p. 436 ■ Ball catch from p. 437 ■ Magnetic lock from p. 437 ■ Door stopper from p. 440 ■ Handle from p. 440 ■ Door lock -KL- from p. 441 ■ Roller module from p. 442 ■ Roller carriage module from p. 443 ■ Safety switch from p. 444 ■ Panels from p. 447 	<p>Functional profiles</p> <p>Heavy duty profiles</p> <p>Protection and partitioning system</p> <p>RK Easywork</p>
		<p>Appendix</p>

Choosing a system

Partitioning system

Condition:

No danger to personnel e.g. from plant or machinery! It does not have to be anchored to the floor.

Application:

Screening
Sound insulation
Division of rooms
Flexible cubicles e.g. welding booths

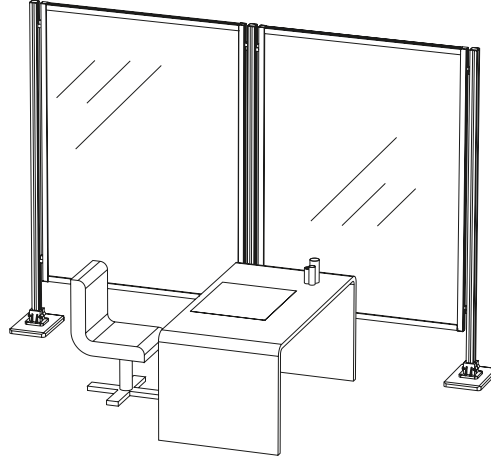

Safety guard to cordon off danger zones

Condition:

Must be anchored to the floor

Application:

For enclosing danger zones, e.g. plant and machinery

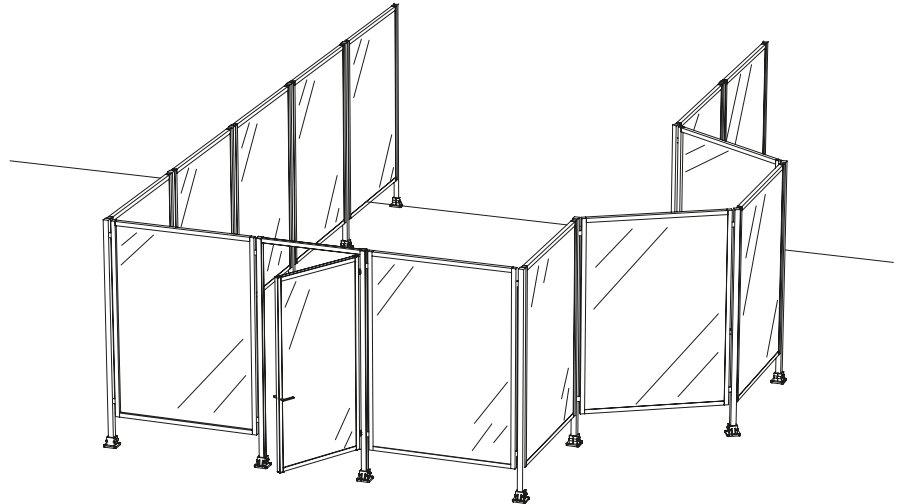

It is imperative to observe the safety distances under DIN EN ISO 13857 to prevent danger zones being reached!

Safety distances

Safety distances

Distance from danger zone
for frame height 2200 mm

to DIN EN ISO 13857
(upper limbs and lower limbs)

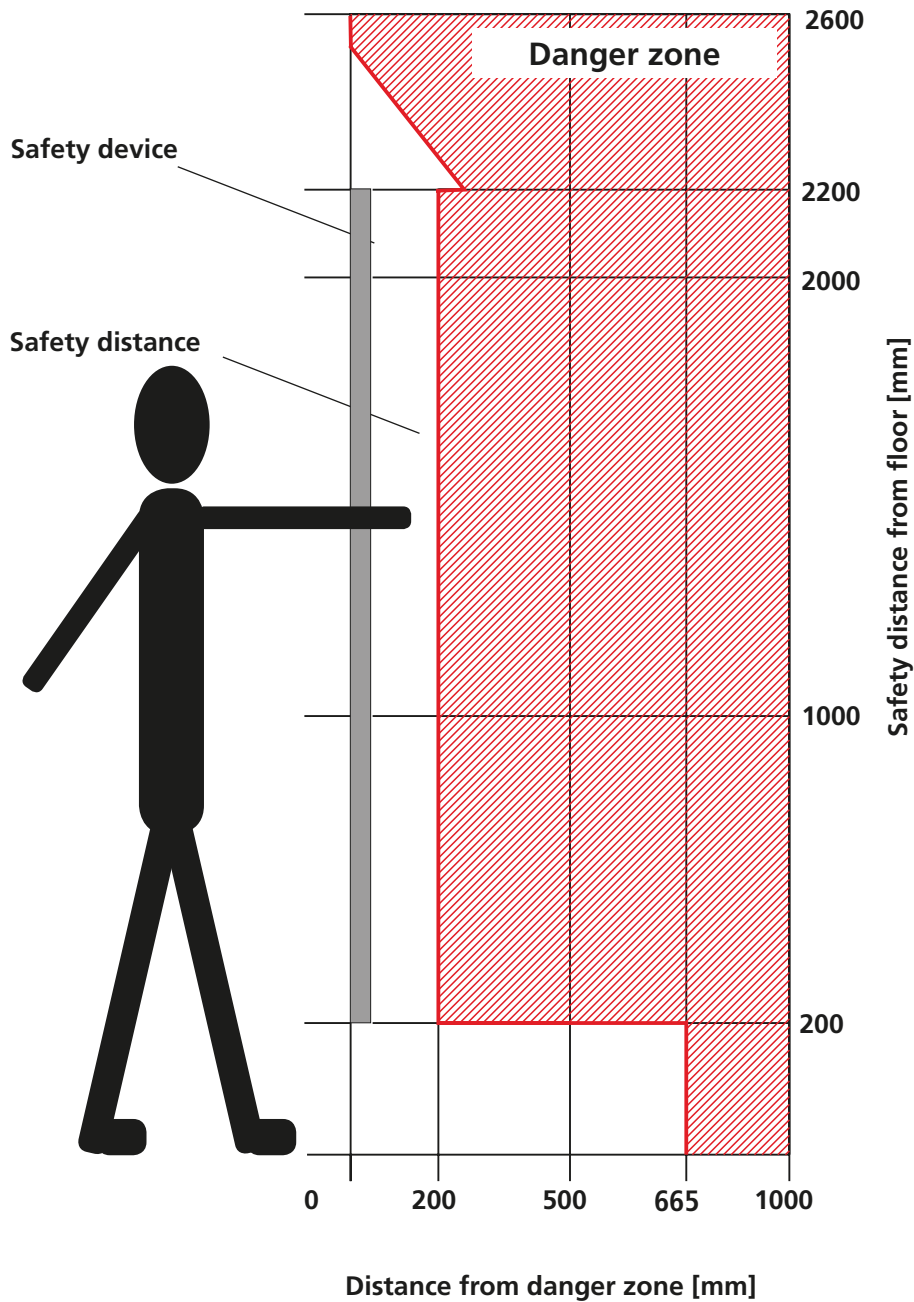

Distance from danger zone
for frame height 1600 mm

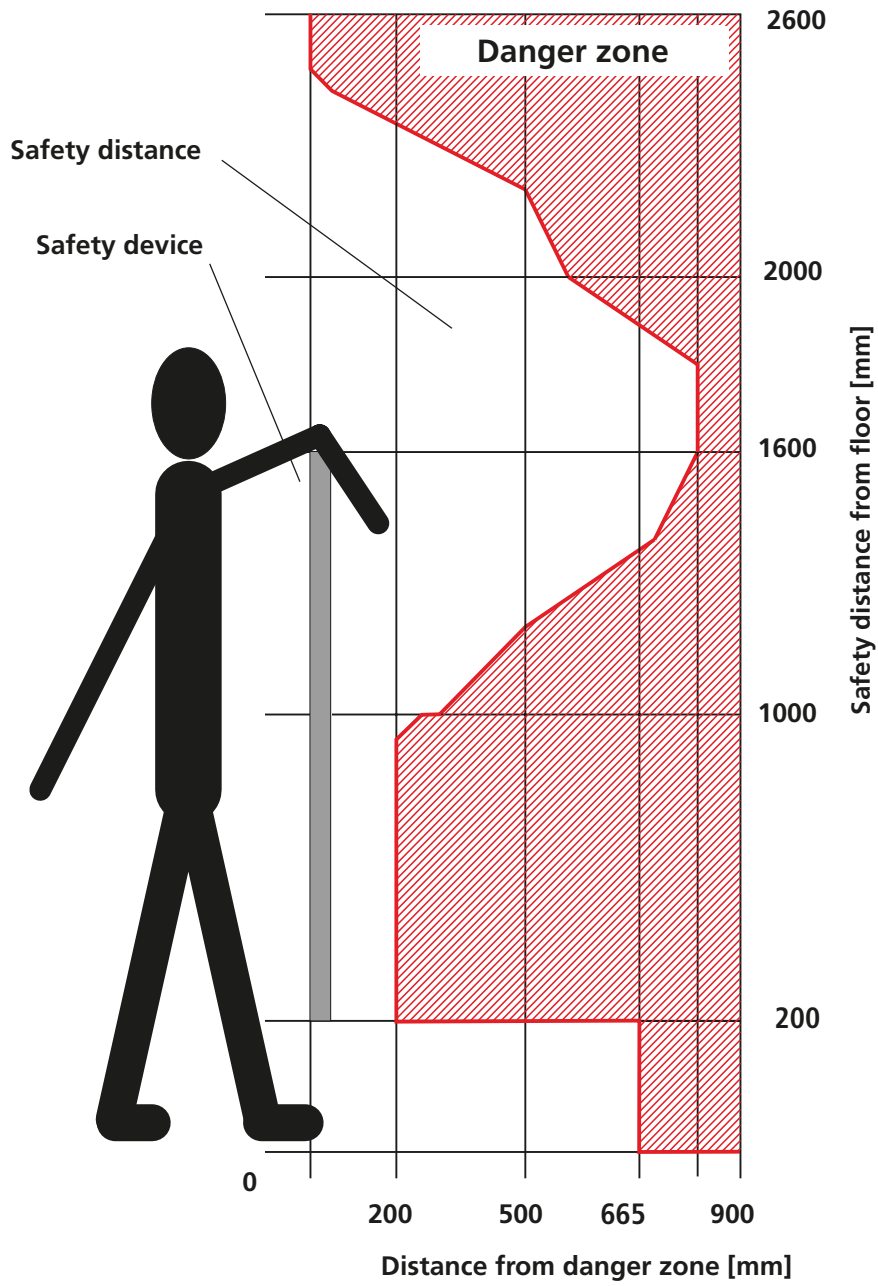

Modular system

The modular system

The modular system allows the user to concentrate on the most important thing – the safety function and its design with minimal time expenditure.

Features:

- Quick and easy on-site installation (with Click&Safe connection element, see page 432)
- Fast assembly and dismantling of individual frames, e.g. for maintenance work on the machine
- Frames with the same module size are interchangeable

Clamping or inserting profile available in the cross-sections 30 mm and 40 mm. (see page 418–424)

Pillar profile 50, S-profile 40x40 or F-profile 50x50 (see page 406–408 Page 426–427)

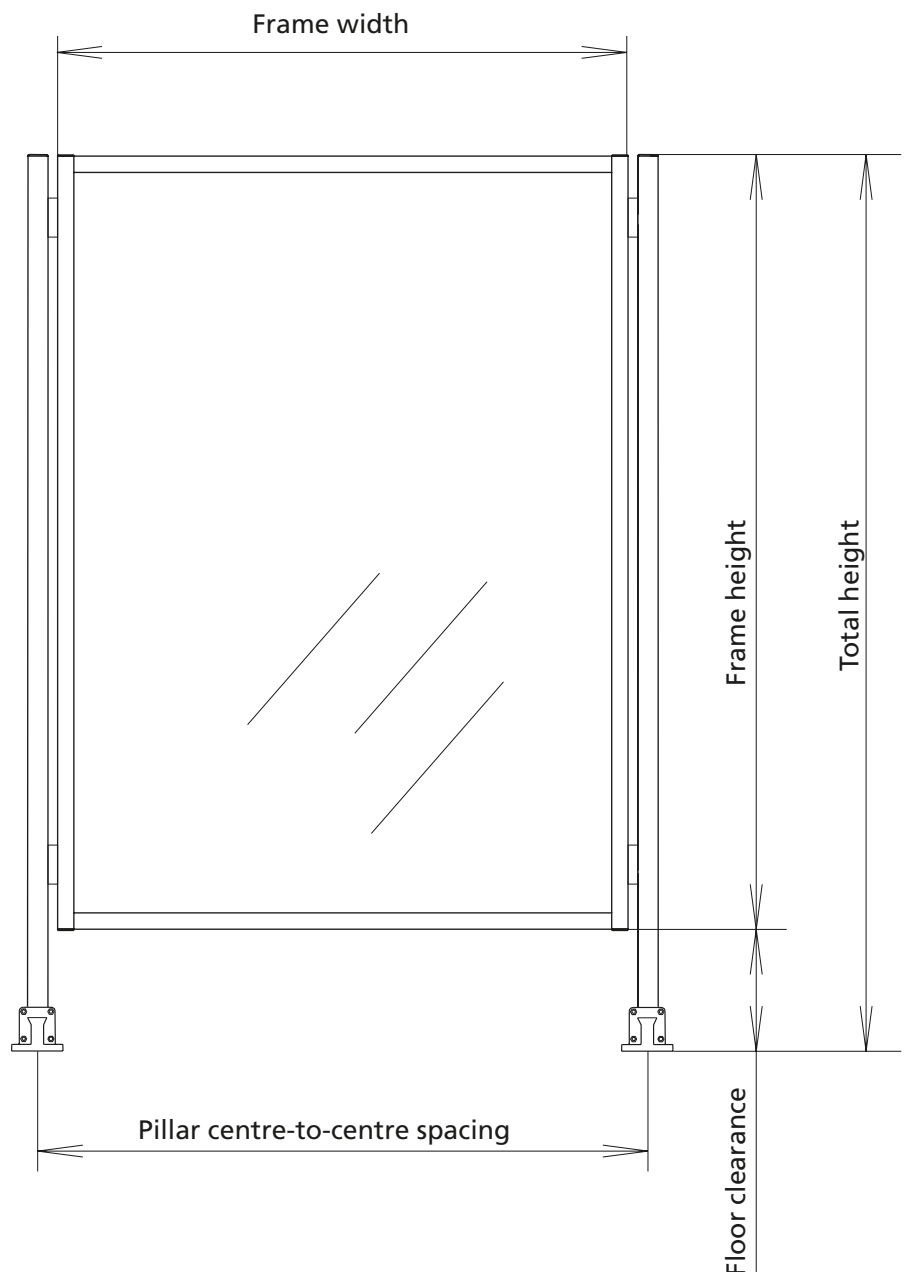

Procedure

1. Planning

a) Calculate the required lengths

Example:

The machine to be protected has the dimensions 5.50 m x 3.50 m. Allowing for the safety distance, you get a rectangle of approx. 6 m x 4 m.

b) The protection system can now be designed in line with requirements with the aid of the different module sizes.

In our example, one solution is as follows:

4 m side = 2 x 2.0 m module

6 m side = 4 x 1.5 m module

Number of pillars = 12

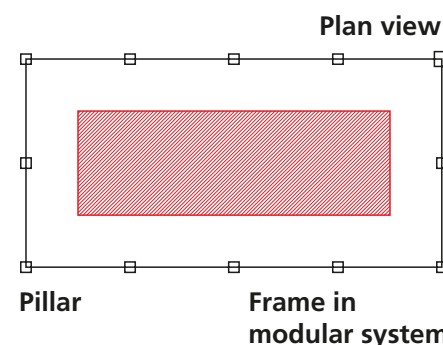

2. Material requirements

a) Pages 409–411 list the different frame versions with different panels.

b) Furthermore, sliding, hinged and lifting doors are available, which are also configured in

the modular system (page 404).

c) Page 406 shows the pillars. The following distinction must be made in relation to the pillars:

■ Protection system = pillar with base clamp (type 1 and 2)

■ Safety guard = pillar with base plate (type 3)

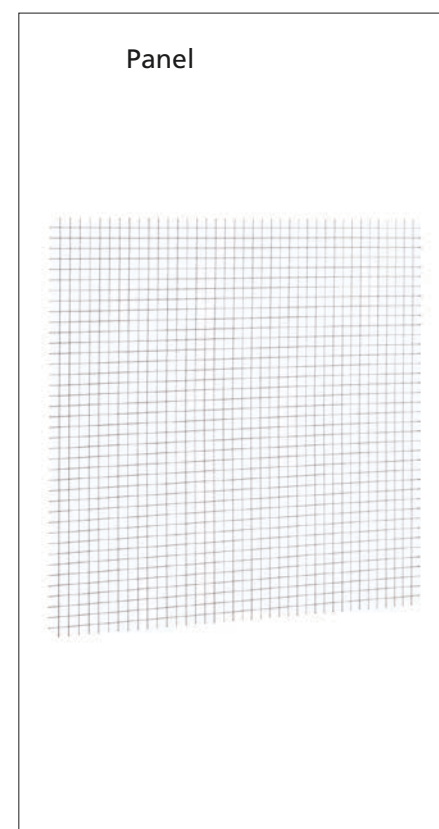
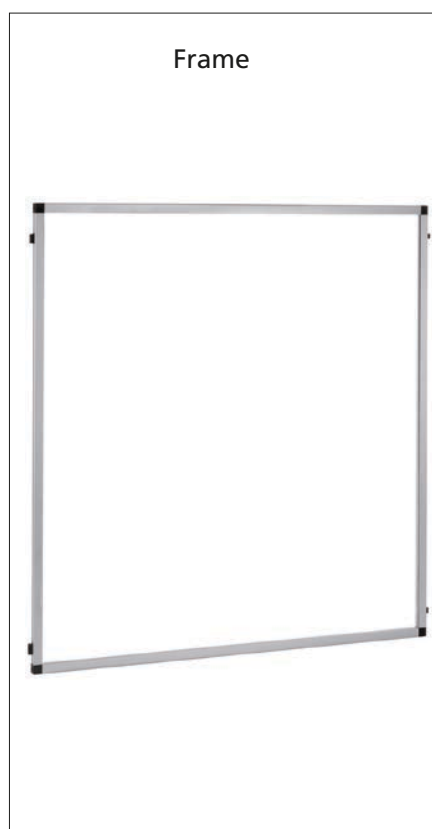
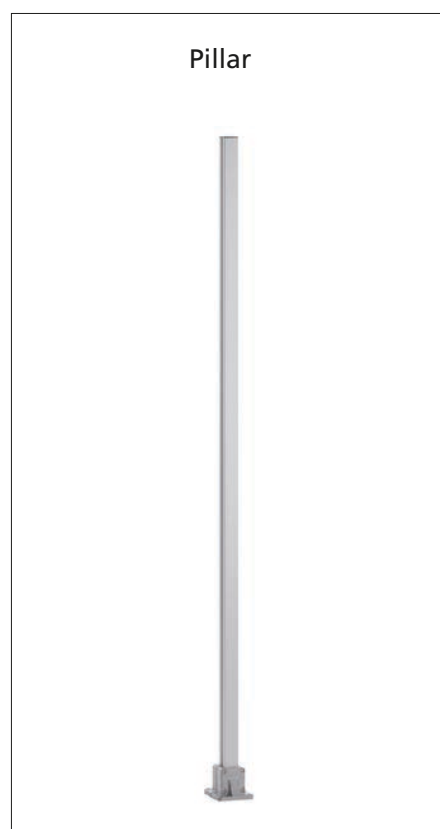

Modular system

Pillar

- Consisting of pillar profile 50 / S-profile 40x40 / F-profile 50x50
- Choice of base versions

Application:

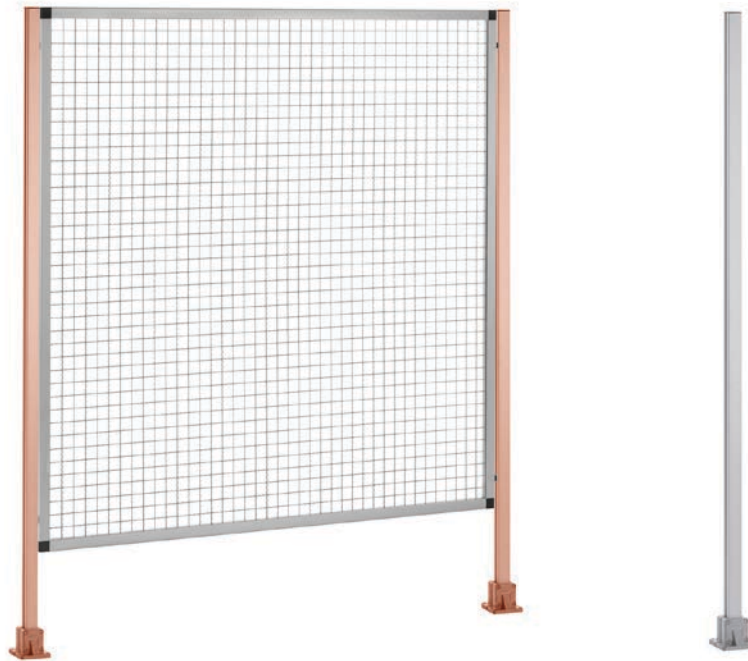



Type 1 (FVV)

For pillar profile S-40x40

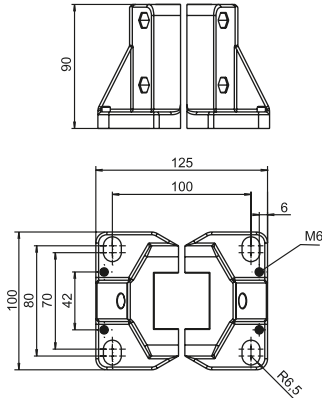

For pillar profile 50, F-50x50

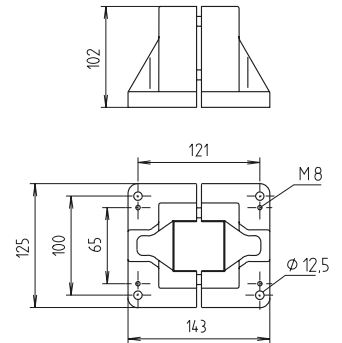

Type 2 (FVA)

For pillar profile 50, F-50x50

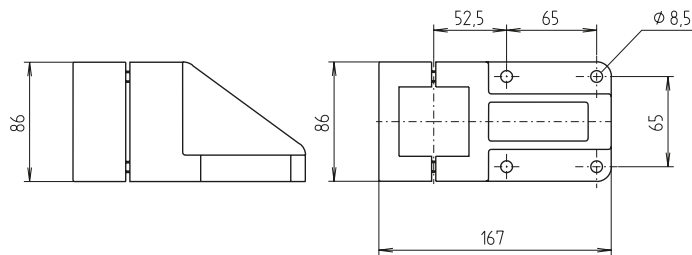

Type 3 (FP)

For pillar profile 50, F-50x50, S-40x40

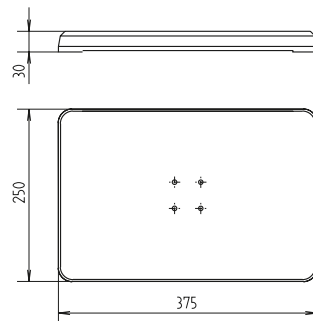

Modular system



Pillar profile S-40x40



Pillar profile F-50x50

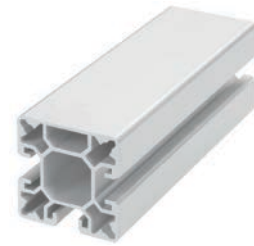

Pillar profile SP-50x50

Order example: Pillar F-50 1600 0000 X

Pillar profile F-50,
Height = 1600,
Version = Type 1 (FVV)

Pillar profile	Tall pillar (max. 6000 mm)	Base version
S-40x40	--- 0000	---
F-50x50	--- 0000	---
SP-50x50	--- 0000	---

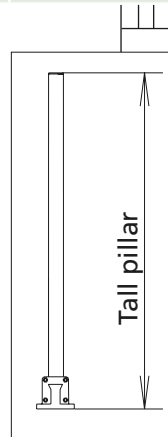

X = type 1 (FVV)
Y = type 2 (FVA, not available for F-40)
Z = type 3 (FP)

Supporting/Levelling shims

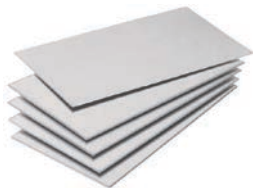

- For levelling with the aid of set screws
- For preventing the set screws from digging into the floor
- Give the base clamp a full contact surface

Material: Galvanised steel

Code No.	Version	Base version	Includes
4080500	Supporting shim 50	Type 1 for pillar profile 50, F-50x50	1 1-mm shim
4014301	Levelling shims 40	Type 1 for pillar profile S-40x40	4 1-mm shims, 1 0.5-mm shim
4014302	Levelling shims 50	Type 1 for pillar profile F-50x50	4 1-mm shims, 1 0.5-mm shim



Panel module version -A-

- Consisting of frame, panels and connection elements

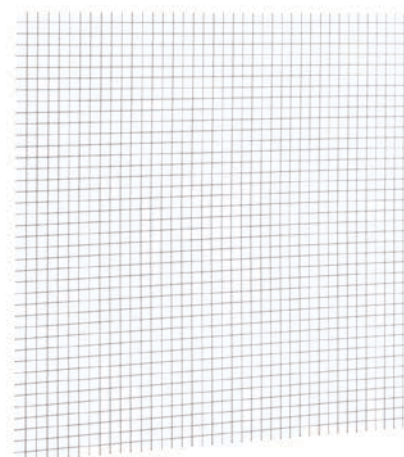
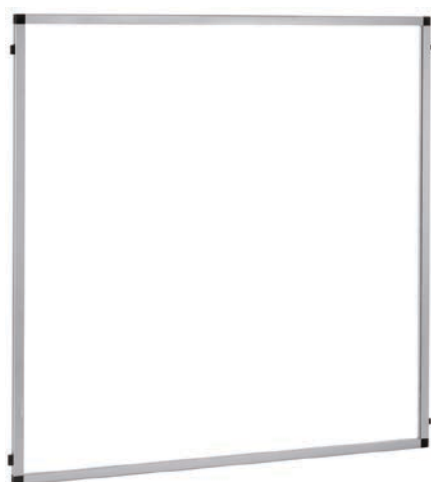

Frame profile, see p. 418-421	Frame height see p. 404	Frame width see p. 404	Choice of panels
Module A, ESP 30	Up to 1900 mm	Up to 1000 mm	A, G
Module A, ESP 40	Up to 1900 mm	Up to 1500 mm	A, I
Module A, ESP 30/2	Up to 1900 mm	Up to 1000 mm	A, G
Module A, ESP 40/2	Up to 1900 mm	Up to 1500 mm	A, I
Module A, ESP 30/2 (40)	Up to 1900 mm	Up to 1000 mm	A, I
Module A, KL 30-II	Up to 1900 mm	Up to 1000 mm	All
Module A, KL 40-II	Up to 1900 mm	Up to 2000 mm	All

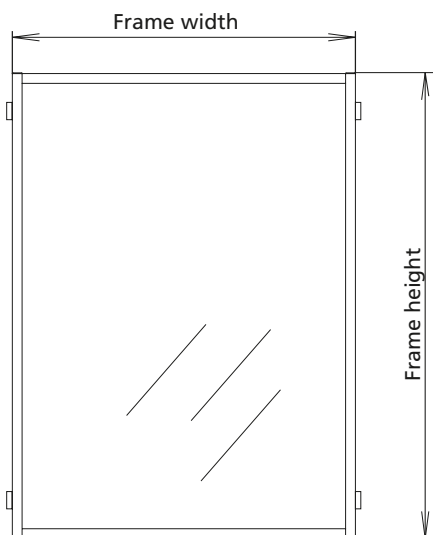

- A = Without panel
- B = Acrylic glass, 6 mm, clear
- C = Acrylic glass, 6 mm, tinted
- D = Makrolon glass, 6 mm, clear
- E = Trespa, 6 mm, brown solid core panel available in widths up to 1500 mm
- F = Composite, 6 mm, anodised, available in widths up to 1500 mm
- G = Wire mesh, 30x30x3, galv. steel
- I = Wire mesh, 40x40x4, galv. steel

Further versions available on request.

Order example:
 Module A, ESP 30 1500 0900 G

Frame profile ESP 30,
 Height=1500,
 Width=900,
 Panel = wire mesh 30x30x3 galv. steel

Modular system

Panel module version -B-

■ Consisting of frame, panels and connection elements, vertical division (in centre)

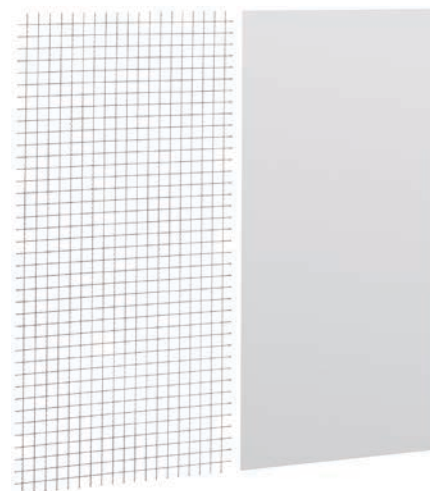

Frame profile, see p. 418-421	Frame height, see p. 404	Frame width, see p. 404	Panel 1 Choice of:	Panel 2 Choice of:
Module B, ESP 30	Up to 1900 mm	Up to 1500 mm	A, G	A, G
Module B, ESP 40	Up to 2500 mm	Up to 2000 mm	A, I	A, I
Module B, ESP 30/2	Up to 1900 mm	Up to 1500 mm	A, G	A, G
Module B, ESP 40/2	Up to 2500 mm	Up to 2000 mm	A, I	A, I
Module B, ESP 30/2 (40)	Up to 1900 mm	Up to 1500 mm	A, I	A, I
Module B, KL 30-II	Up to 1900 mm	Up to 1500 mm	All	All
Module B, KL 40-II	Up to 2500 mm	Up to 2000 mm	All	All



- A = Without panel
- B = Acrylic glass, 6 mm, clear
- C = Acrylic glass, 6 mm, tinted
- D = Makrolon glass, 6 mm, clear
- E = Trespa, 6 mm, brown solid core panel available in widths up to 1500 mm
- F = Composite, 6 mm, anodised, available in widths up to 1500 mm
- G = Wire mesh, 30x30x3, galv. steel
- I = Wire mesh, 40x40x4, galv. steel

Further versions available on request.

Order example:
 Module B, KL 40 2000 1200 BI
 Frame profile KL 40-II,
 Height = 2000,
 Width = 1200,
 Panel 1 = Acrylic glass, 6 mm, clear
 Panel 2 = wire mesh 40x40x4 galv. steel

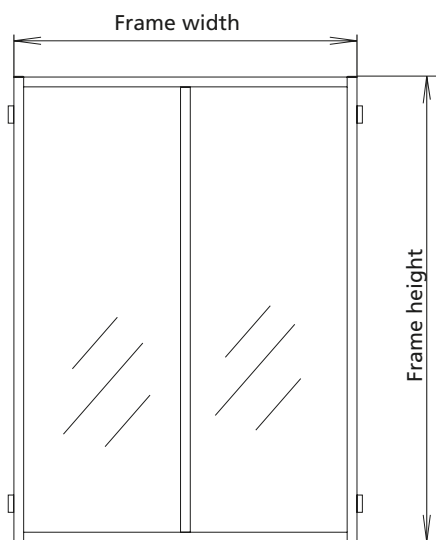

Panel module version -C-

- Consisting of frame, panels and connection elements, horizontal division (in centre)



Frame profile, see p. 418-421	Frame height, see p. 404	Frame width, see p. 404	Panel 1 Choice of:	Panel 2 Choice of:
Module C, ESP 30	Up to 1900 mm	Up to 1500 mm	A, G	A, G
Module C, ESP 40	Up to 2500 mm	Up to 2000 mm	A, I	A, I
Module C, ESP 30/2	Up to 1900 mm	Up to 1500 mm	A, G	A, G
Module C, ESP 40/2	Up to 2500 mm	Up to 2000 mm	A, I	A, I
Module C, ESP 30/2 (40)	Up to 1900 mm	Up to 1500 mm	A, I	A, I
Module C, KL 30-II	Up to 1900 mm	Up to 1500 mm	All	All
Module C, KL 40-II	Up to 2500 mm	Up to 2000 mm	All	All

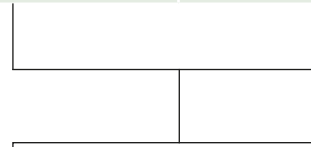

- A = Without panel
- B = Acrylic glass, 6 mm, clear
- C = Acrylic glass, 6 mm, tinted
- D = Makrolon glass, 6 mm, clear
- E = Trespa, 6 mm, brown solid core panel available in widths up to 1500 mm
- F = Composite, 6 mm, anodised, available in widths up to 1500 mm
- G = Wire mesh, 30x30x3, galv. steel
- I = Wire mesh, 40x40x4, galv. steel

Further versions available on request.

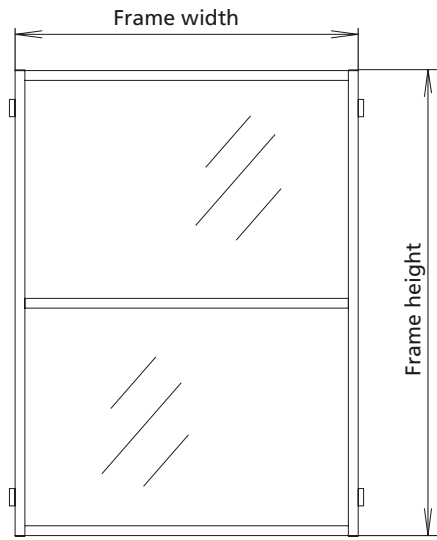

Order example:
 Module C, KL 40 2000 0850 BI

Frame profile KL 40-II,
 Height = 2000,
 Width = 850,
 Panel 1 = Acrylic glass, 6 mm, clear
 Panel 2 = wire mesh 40x40x4 galv. steel

Modular system

Hinged door

- Consisting of pillar profile 50 with base version type 1, top cross strut
- Choice of door lock

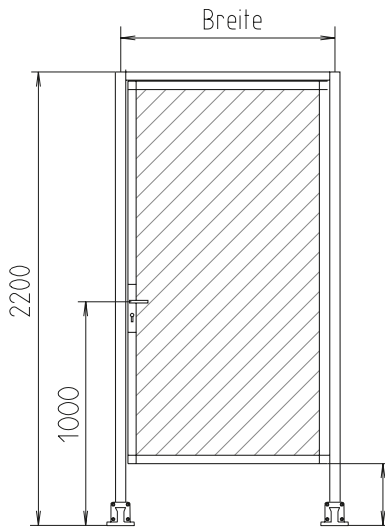

Please indicate floor clearance in the order

Fixed knob on outside in panic lock version



Version DIN right

Type	Mounting	Height	Width	Panel	Door lock	Frame profile
Hinged door	-	----	----	-	-	KL 30-II
	-	----	----	-	-	KL 40-II

W = Panic lock
 X = Cylinder lock with handle set
 Y = Magnetic lock with handle
 Z = Ball catch with handle

A = Without panel
 B = Acrylic glass, 6 mm, clear
 C = Acrylic glass, 6 mm, tinted
 D = Makrolon glass, 6 mm, clear
 E = Trespa, 6 mm, brown solid core panel available in widths up to 1500 mm
 F = Composite, 6 mm, anodised, available in widths up to 1500 mm
 G = Wire mesh, 30x30x3, galv. steel
 I = Wire mesh, 40x40x4, galv. steel

F = DIN right mounting
 G = DIN left mounting

Standard height:
 2200 = 2200 mm

Standard width:
 0800 = 0800 mm
 1000 = 1000 mm

Further widths/heights available on request.

Order example:
 Hinged door F 2200 1000 DY
 DIN right,
 Height = 2200,
 Width = 1000,
 Panel = Makrolon,
 Door lock = Magnetic lock

Double-winged hinged door

- Consisting of pillar profile 50 with base version type 1, top cross strut
- Choice of door lock
- Pillar roller available as an optional extra

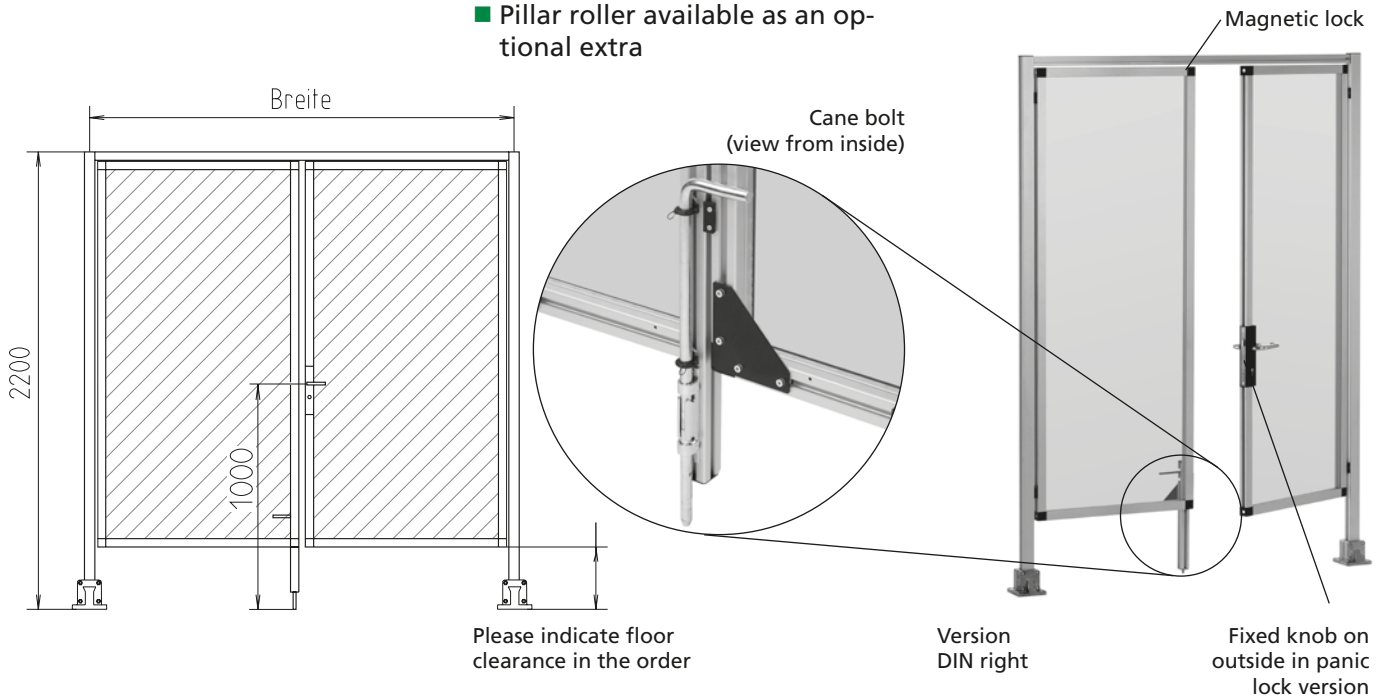

Type	Mounting	Height	Width	Panel	Door lock	Frame profile
Double-wing hinged door	-	---	---	-	-	KL 40-II

L = DIN right mounting
M = DIN left mounting

Standard height:
2200 = 2200 mm

Standard width:
1500 = 1500 mm
2000 = 2000 mm

Further widths/heights available on request.

W = Panic lock
X = Cylinder lock with handle set
Y = Magnetic lock with handle
Z = Ball catch with handle

A = Without panel
B = Acrylic glass, 6 mm, clear
C = Acrylic glass, 6 mm, tinted
D = Makrolon glass, 6 mm, clear
E = Trespa, 6 mm, brown solid core panel available in widths up to 1500 mm
F = Composite, 6 mm, anodised, available in widths up to 1500 mm
G = Wire mesh, 30x30x3, galv. steel
I = Wire mesh, 40x40x4, galv. steel

Order example:
Double-wing hinged door L 2200 1500 DW
DIN right,
Height = 2200,
Width = 1500,
Panel = Makrolon,
Door lock = panic lock

Modular system

Sliding door

- Consisting of pillar profil 50 with base version type 1
- Guide with sliding door profile 40 and roller carriage

Sliding door profile, roller carriage (view from inside)

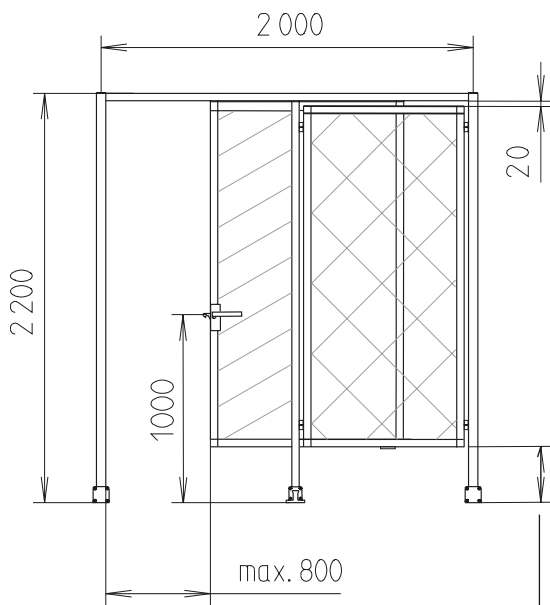

Please indicate floor clearance in the order

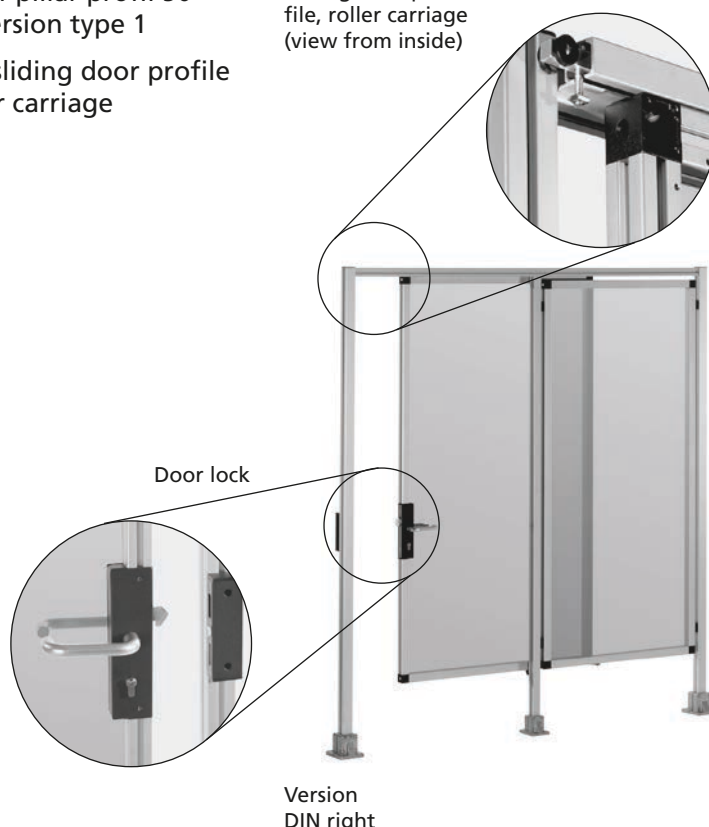

Type	Mounting	Height	Width	Panel	Frame profile
Sliding door	-	---	---	-	KL 40-II

N = DIN right mounting
P = DIN left mounting

Standard height: 2200 = 2200 mm
Standard width: 2000 = 2000 mm

A = Without panel
B = Acrylic glass, 6 mm, clear
C = Acrylic glass, 6 mm, tinted
D = Makrolon glass, 6 mm, clear
E = Trespa, 6 mm, brown solid core panel available in widths up to 1500 mm
F = Composite, 6 mm, anodised, available in widths up to 1500 mm
G = Wire mesh, 30x30x3, galv. steel
I = Wire mesh, 40x40x4, galv. steel

Further widths/heights available on request.

Order example:
Sliding door N 2200 2000 IB

Sliding door right,
Height = 2200,
Width = 2000,
Panel1 = Wire mesh,
Panel2 = Clear acrylic

Lifting door

- Consisting of pillar profile F-profile 80-L with base version type 1
- Incl. pulleys, counterweights and infinitely adjustable brake

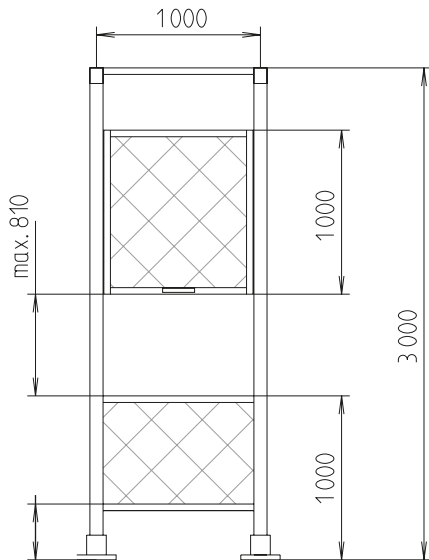

Please indicate floor clearance in the order

Door limiter with shock absorbers, counterweight pulley system

Infinitely adjustable holding brake in handle

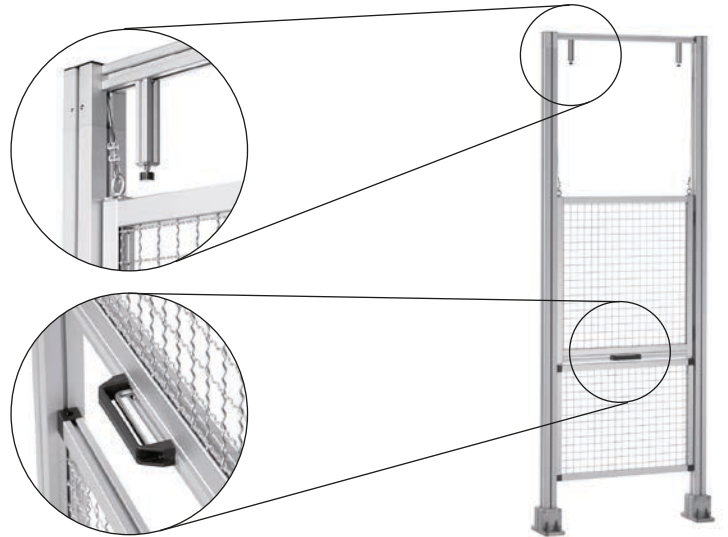

Type	Height	Width	Panel		Frame profile
			1	2	
Lifting door	---	---	-	-	KL 40-II

Standard width: 1000 = 1000 mm

Standard height: 3000 = 3000 mm

Further widths/heights available on request.

A = Without panel
 B = Acrylic glass, 6 mm, clear
 C = Acrylic glass, 6 mm, tinted
 D = Makrolon glass, 6 mm, clear
 E = Trespa, 6 mm, brown solid core panel available in widths up to 1500 mm
 F = Composite, 6 mm, anodised, available in widths up to 1500 mm
 G = Wire mesh, 30x30x3, galv. steel
 I = Wire mesh, 40x40x4, galv. steel

Order example:
 Lifting door 3000 1000 BE

Frame profile = KL 40-II
 Height = 3000
 Width = 1000
 Panel 1 = Clear acrylic
 Panel 2 = Trespa

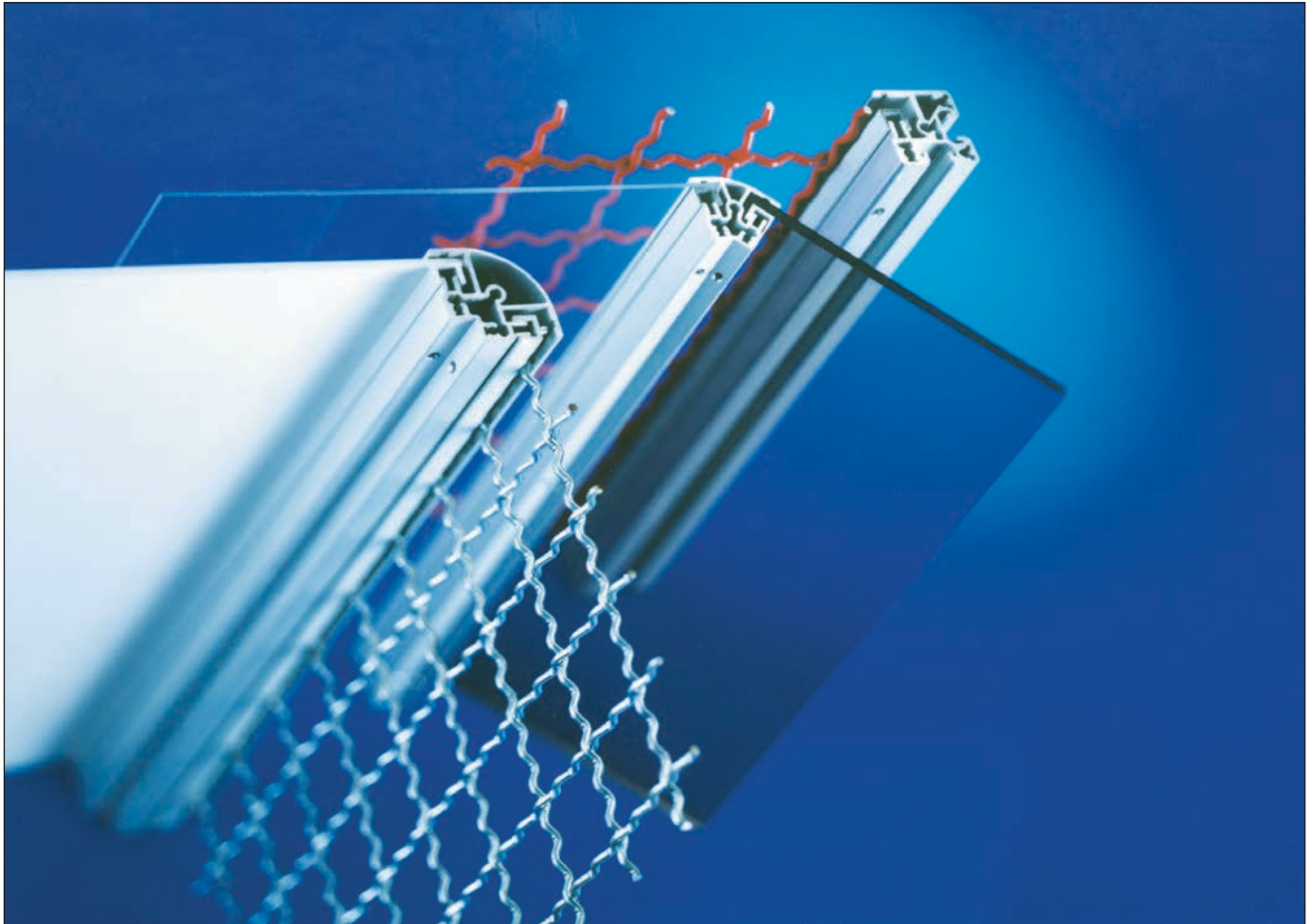

Inserting profiles ESP for wish mesh

Features:

- Special profile for inserting wire meshes (size 30 for 30x30x3, size 40 for 40x40x4,
- Type ESP 30/2 (40) and ESPD 30x40 (40) for 40x40x4)
- Visually attractive and easy to clean thanks to profile visible surfaces without longitudinal slot.
- Corner joint ensures quick and rotation-locked assembly
- High stability thanks to high insertion depth

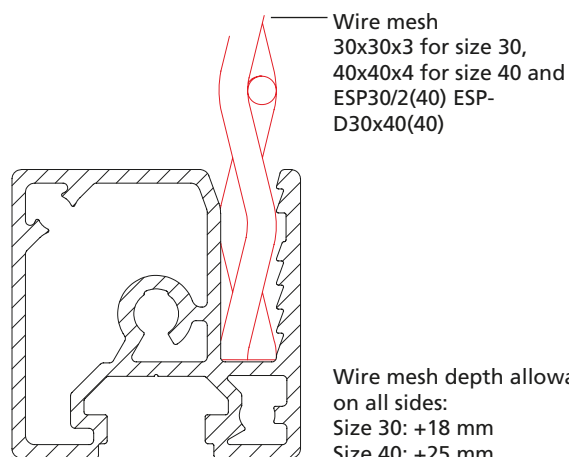
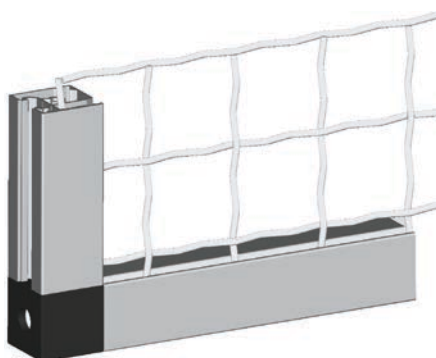

Clamping profiles

■ A clamping screw presses the clamping bar against the panel. This ensures secure seating and tolerances can be absorbed by the panels without any difficulty.

Features:

- Secure seating, no flapping because the panels are clamped
- Visually attractive and easy to clean thanks to smooth visible surface
- Various angle versions for different applications
- Suitable for panel elements with a wall thickness of up to 10 mm
- Panel depth allowances on all sides:

Size 30	+10 mm
Size 40	+15 mm

Includes:

Basic profile, clamping bar and set screws (hole spacing approx. 200 mm)

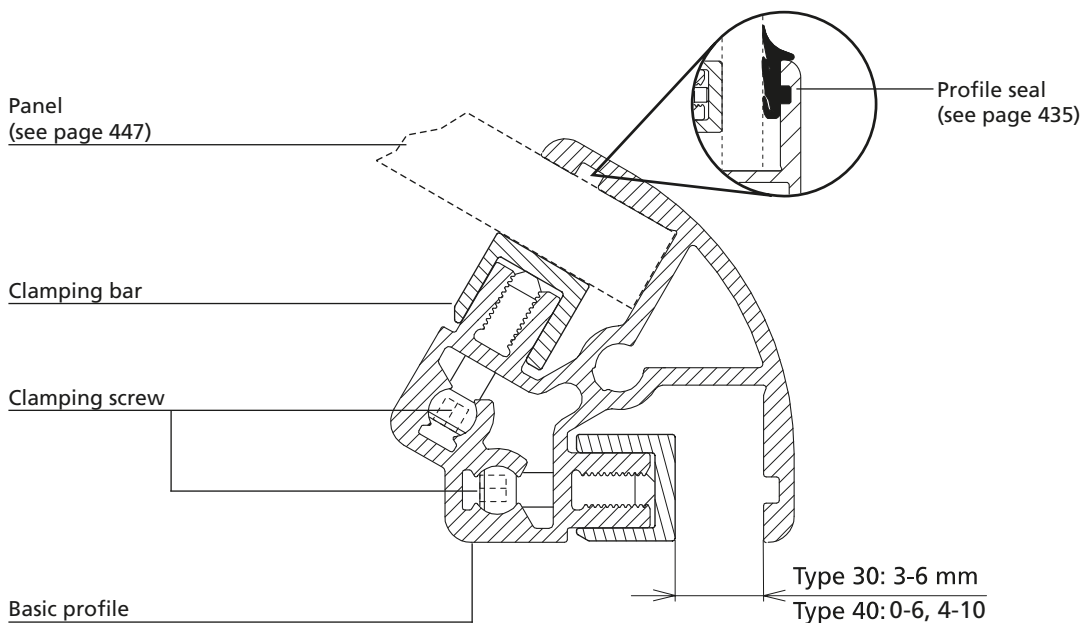

Profiles

Inserting profile ESP for wish mesh

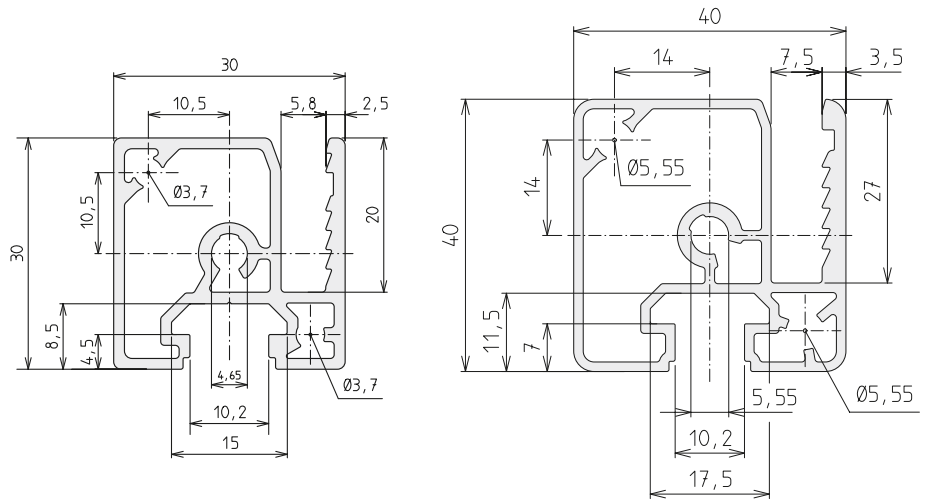

Code No.	Size	Version	For wire mesh	Anodised
4895000	30	Cut to size (max. 6000 mm)	30x30x3	Clear
4895001	30	6000 mm bar	30x30x3	Clear
4905000	40	Cut to size (max. 6000 mm)	40x40x4	Clear
4905001	40	6000 mm bar	40x40x4	Clear

Inserting profile ESP/2 for wish mesh

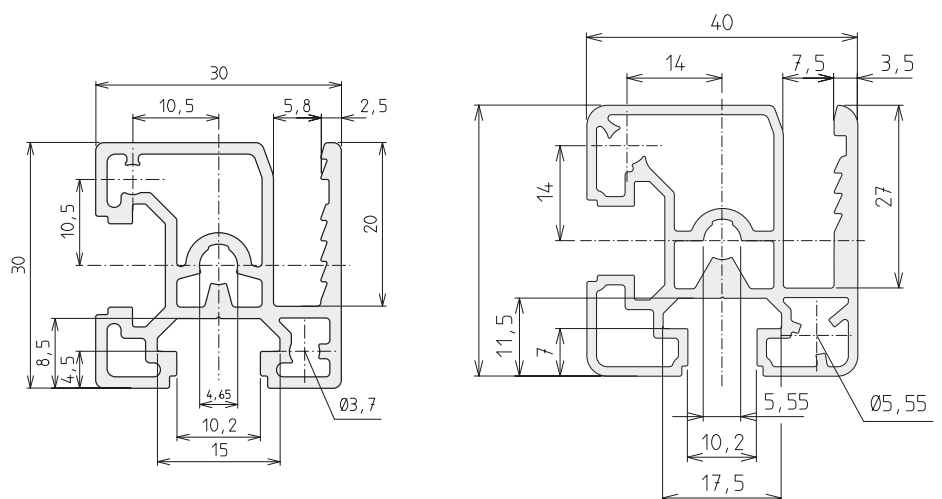
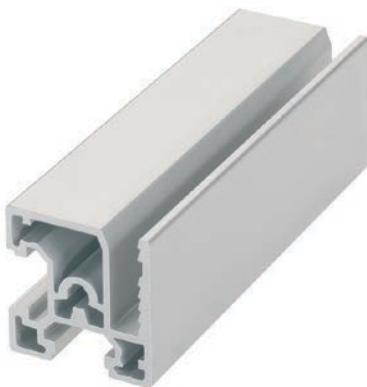

Code No.	Size	Version	For wire mesh	Anodised
4935000	30	Cut to size (max. 6000 mm)	30x30x3	Clear
4935001	30	6000 mm bar	30x30x3	Clear
4945000	40	Cut to size (max. 6000 mm)	40x40x4	Clear
4945001	40	6000 mm bar	40x40x4	Clear

Inserting profile ESP 30/2 (40) for wire mesh

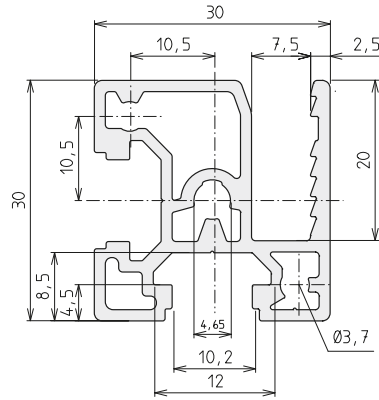
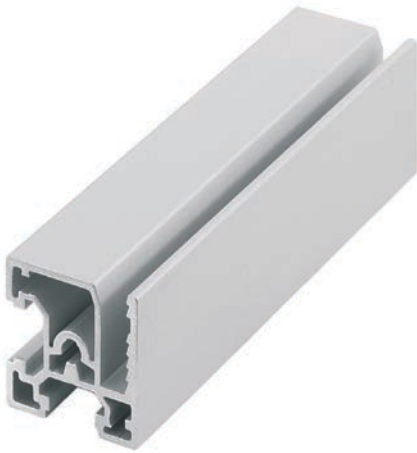

Code No.	Size	Version	For wire mesh	Anodised
4995000	30	Cut to size (max. 6000 mm)	40x40x4	Clear
4995001	30	6000 mm bar	40x40x4	Clear

Inserting profile ESPD 30x40 (40) for wire mesh

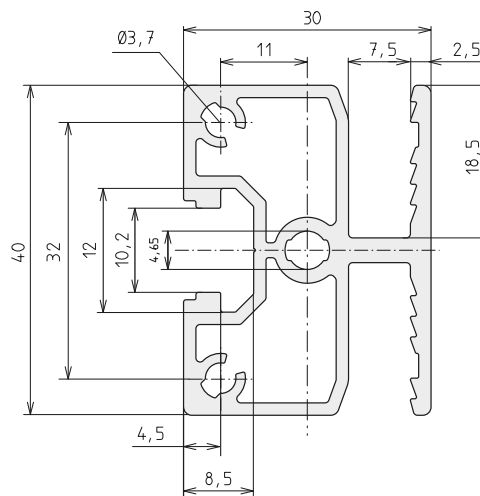
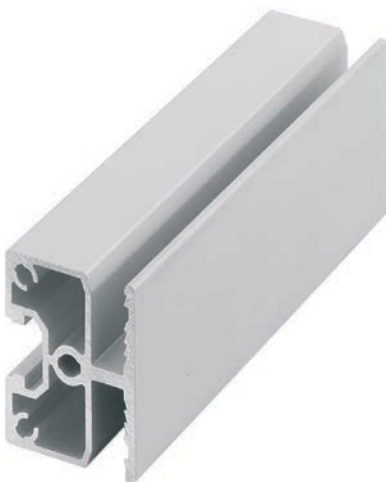

Code No.	Size	Version	For wire mesh	Anodised
4985000	30	Cut to size (max. 6000 mm)	40x40x4	Clear
4985001	30	6000 mm bar	40x40x4	Clear

Clamping profile KLE

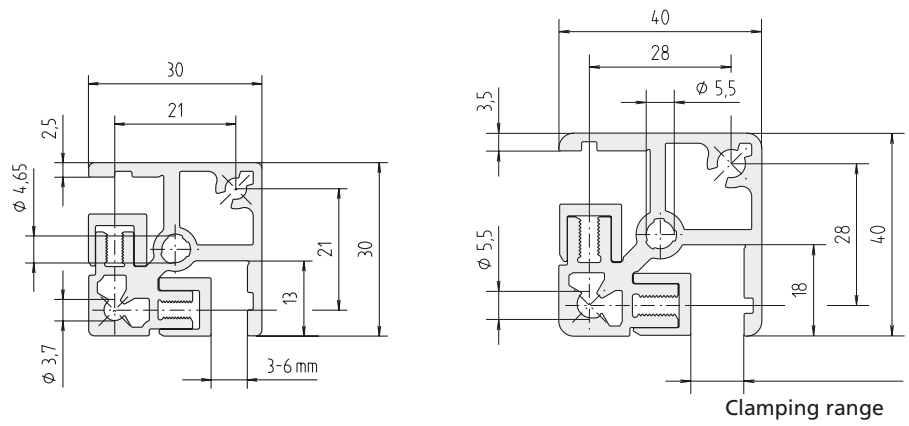
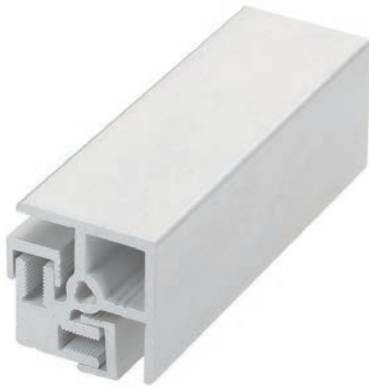

Code No.	Size	Version	Clamping range	Anodised
4705008	30	Cut to size (max. 6000 mm)	3 - 6 mm	Clear
4705009	30	6000 mm bar	3 - 6 mm	Clear
4715100	40	Cut to size (max. 6000 mm)	0 - 6 mm	Clear
4715101	40	6000 mm bar	0 - 6 mm	Clear
4715008	40	Cut to size (max. 6000 mm)	4 - 10 mm	Clear
4715009	40	6000 mm bar	4 - 10 mm	Clear

Profiles



Clamping profile KLV-15

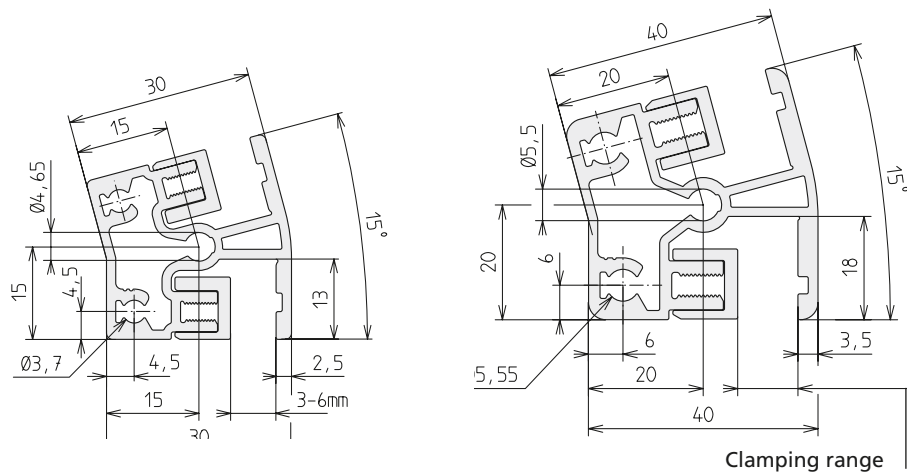

Code No.	Size	Version	Clamping range	Anodised
4405000	30	Cut to size (max. 6000 mm)	3 - 6 mm	Clear
4405001	30	6000 mm bar	3 - 6 mm	Clear
4455100	40	Cut to size (max. 6000 mm)	0 - 6 mm	Clear
4455101	40	6000 mm bar	0 - 6 mm	Clear
4455000	40	Cut to size (max. 6000 mm)	4 - 10 mm	Clear
4455001	40	6000 mm bar	4 - 10 mm	Clear



Clamping profile KLV-30

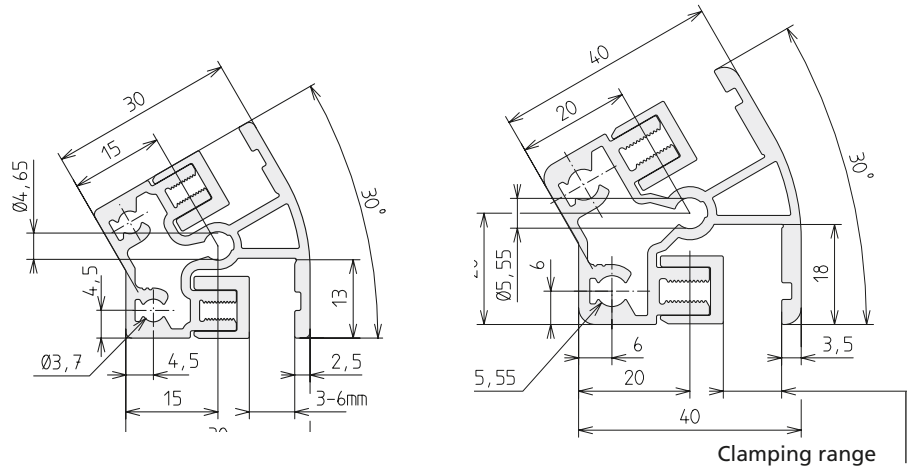
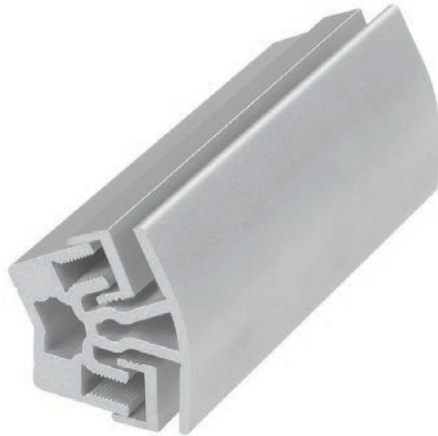

Code No.	Size	Version	Clamping range	Anodised
4415000	30	Cut to size (max. 6000 mm)	3 - 6 mm	Clear
4415001	30	6000 mm bar	3 - 6 mm	Clear
4465100	40	Cut to size (max. 6000 mm)	0 - 6 mm	Clear
4465101	40	6000 mm bar	0 - 6 mm	Clear
4465000	40	Cut to size (max. 6000 mm)	4 - 10 mm	Clear
4465001	40	6000 mm bar	4 - 10 mm	Clear

Clamping profile KLV-45

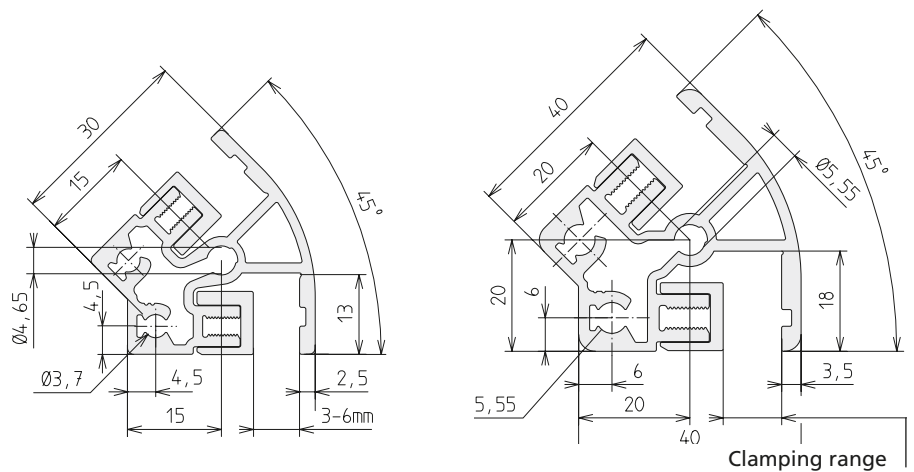

Code No.	Size	Version	Clamping range	Anodised
4425000	30	Cut to size (max. 6000 mm)	3 - 6 mm	Clear
4425001	30	6000 mm bar	3 - 6 mm	Clear
4475100	40	Cut to size (max. 6000 mm)	0 - 6 mm	Clear
4475101	40	6000 mm bar	0 - 6 mm	Clear
4475000	40	Cut to size (max. 6000 mm)	4 - 10 mm	Clear
4475001	40	6000 mm bar	4 - 10 mm	Clear

Profiles

Clamping profile KLV-60

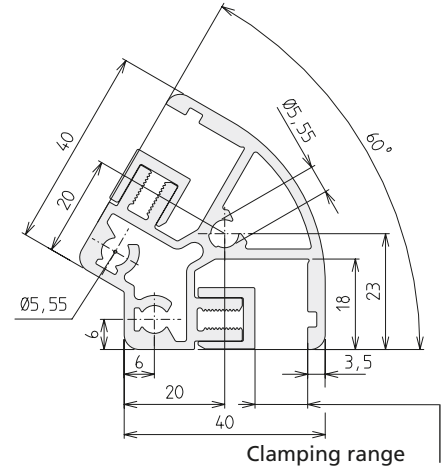
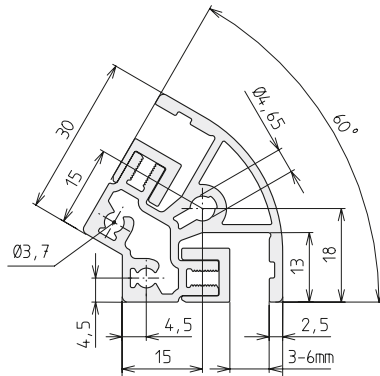

Code No.	Size	Version	Clamping range	Anodised
4445000	30	Cut to size (max. 6000 mm)	3 - 6 mm	Clear
4445001	30	6000 mm bar	3 - 6 mm	Clear
4495100	40	Cut to size (max. 6000 mm)	0 - 6 mm	Clear
4495101	40	6000 mm bar	0 - 6 mm	Clear
4495000	40	Cut to size (max. 6000 mm)	4 - 10 mm	Clear
4495001	40	6000 mm bar	4 - 10 mm	Clear

Clamping profile KLV-90

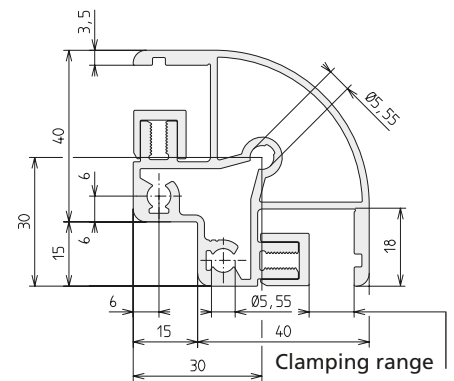
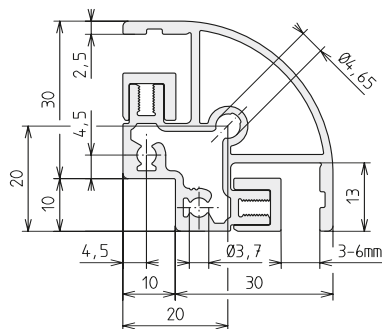

Code No.	Size	Version	Clamping range	Anodised
4435000	30	Cut to size (max. 6000 mm)	3 - 6 mm	Clear
4435001	30	6000 mm bar	3 - 6 mm	Clear
4485100	40	Cut to size (max. 6000 mm)	0 - 6 mm	Clear
4485101	40	6000 mm bar	0 - 6 mm	Clear
4485000	40	Cut to size (max. 6000 mm)	4 - 10 mm	Clear
4485001	40	6000 mm bar	4 - 10 mm	Clear



Sliding door profile STP

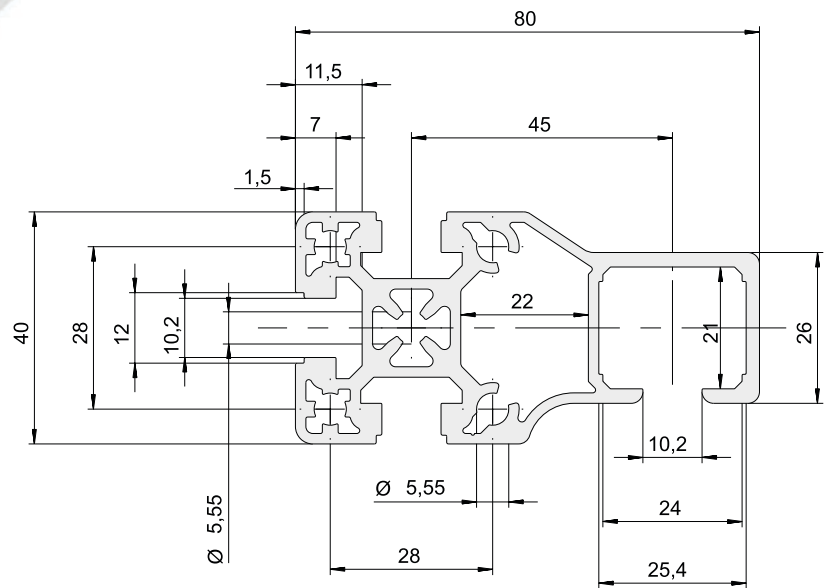
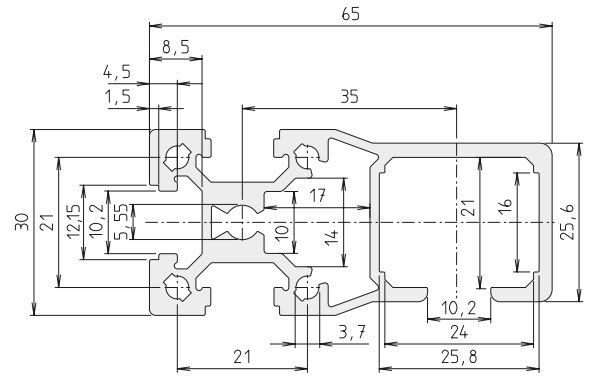
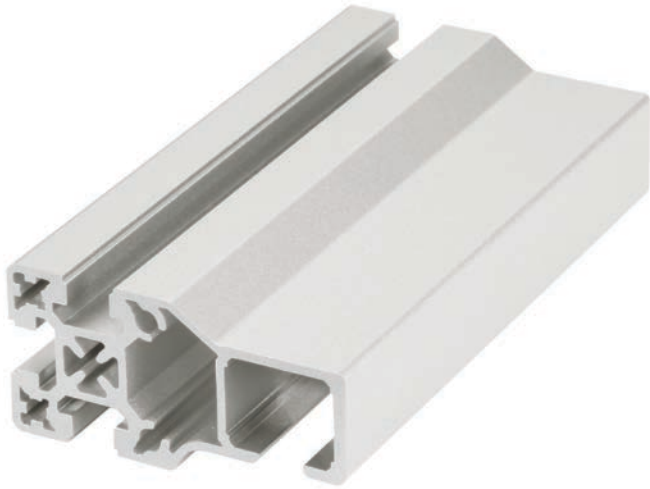

Code No.	Size	Version	Anodised
4175000	30	Cut to size (max. 6000 mm)	Clear
4175001	30	6000 mm bar	Clear
4185000	40	Cut to size (max. 6000 mm)	Clear
4185001	40	6000 mm bar	Clear

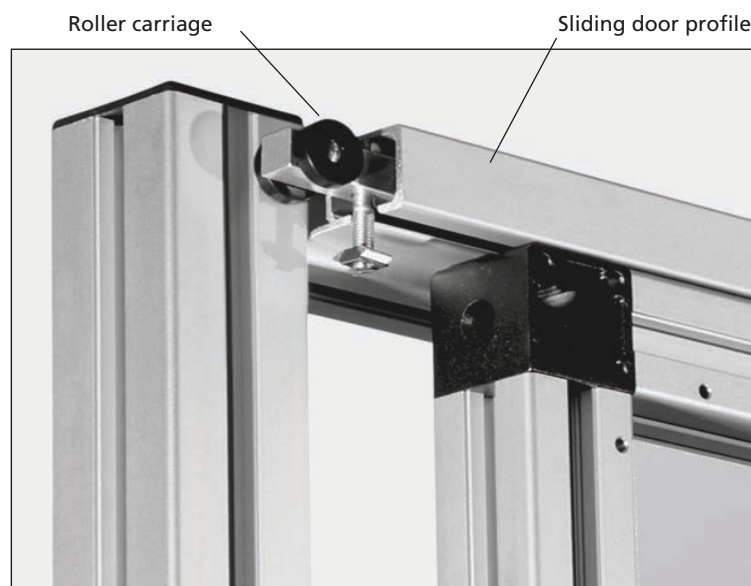

Application example sliding door profile

Profiles

Pillar profile S-40x40

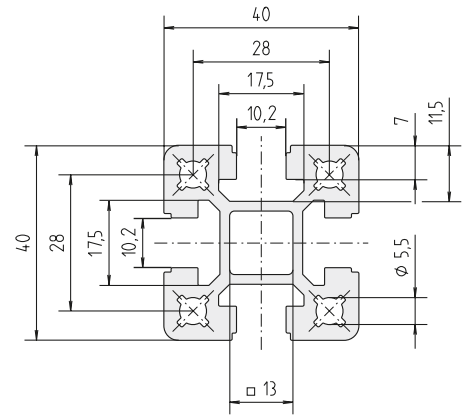
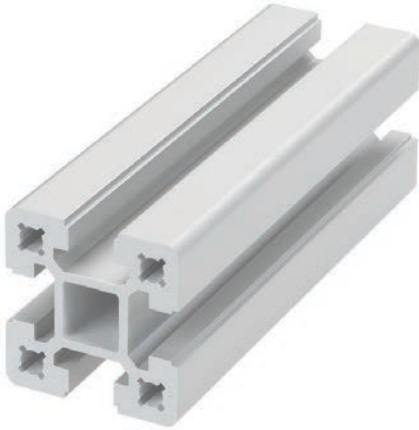

Code No.	Size	Version	Anodised
4015000	40	Cut to size (max. 6000 mm)	Clear
4015001	40	6000 mm bar	Clear

Pillar profile F-50x50

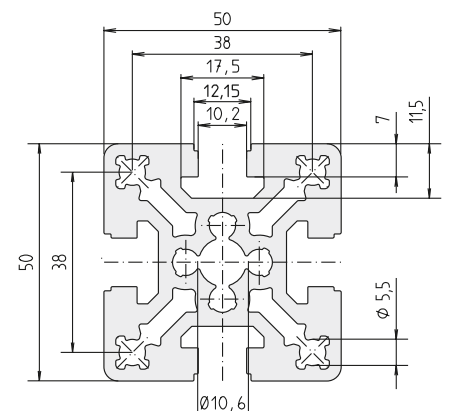

Code No.	Size	Version	Anodised
4085000	50	Cut to size (max. 6000 mm)	Clear
4085001	50	6000 mm bar	Clear

Pillar profile SP-50x50

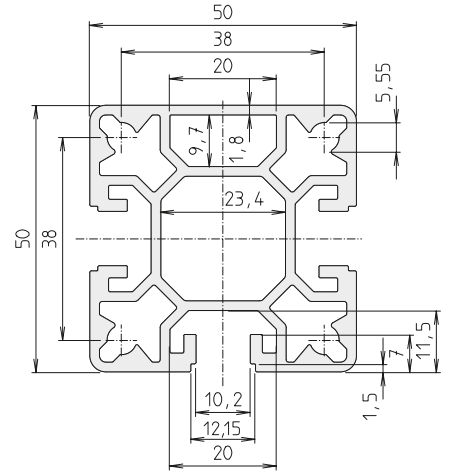
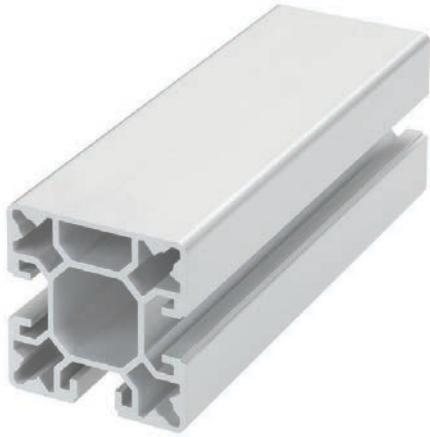

Code No.	Size	Version	Anodised
4635000	50	Cut to size (max. 6000 mm)	Clear
4635001	50	6000 mm bar	Clear

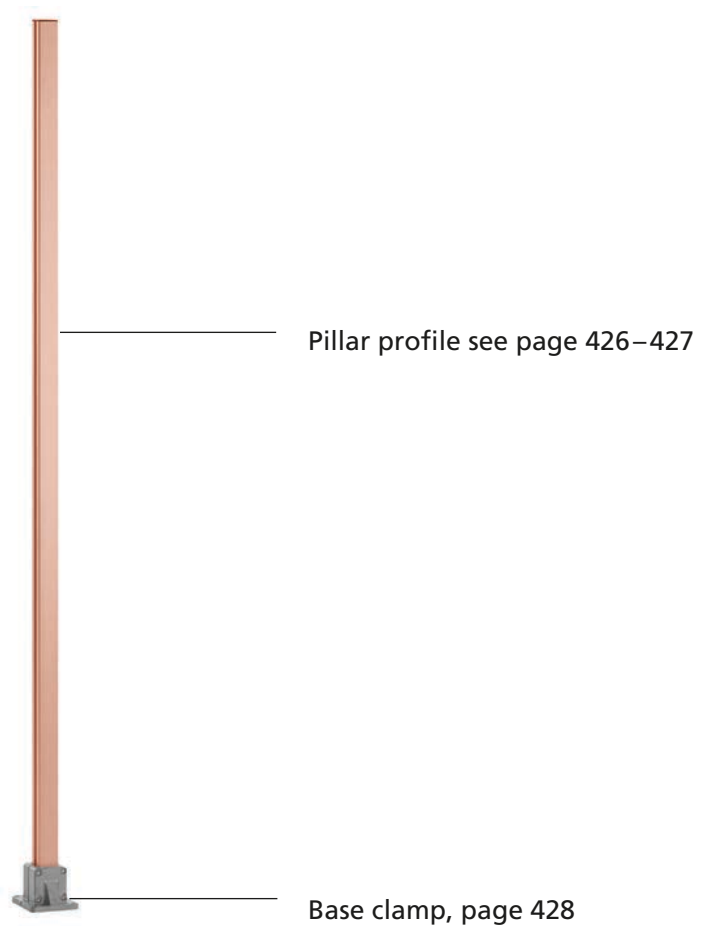

Complete pillars, page 406

Base clamp FVV

- Clamp to take size 40 and 50 pillar profiles. See page 426–427.
- Set screws can be used to compensate for unevenness.
- Levelling shims give the base clamp a full contact surface.

Base clamp

Material: Gravity die-cast aluminium

Includes:

Clamp, set screw and clamping screws

Supporting shim

Material: Steel

Includes: One 1-mm shim

Levelling shims

Material: Aluminium

Includes: The Code No. includes one set of 4 1-mm shims and 1 0.5-mm shim.



For pillar profile S-40x40

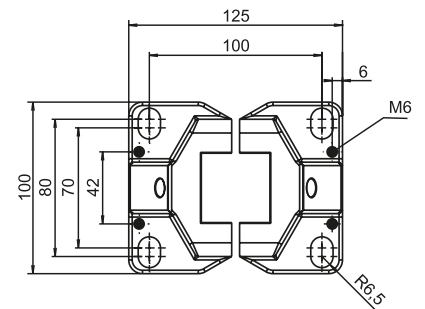
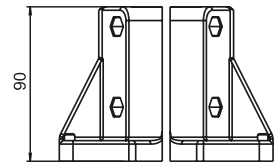

For pillar profile 50, F-50x50

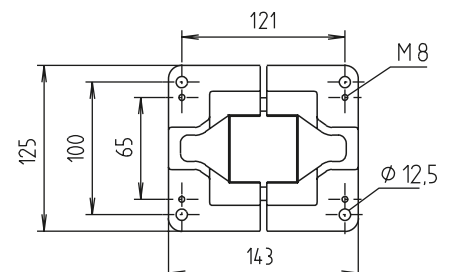
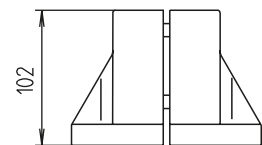

Code No.	Type
4014312	Base clamp FVV-S 40
4084300	Base clamp FVV-S 50
4080500	Supporting shim for FVV 50
4014301	Levelling shims for FVV 40
4014302	Levelling shims for FVV 50

Fixing bolt

- For fixing type 1 and 2 base versions (see page) and the 60° support (see below) to the substrate.
- The Order No. includes one pack of 4 fasteners.

Material:
Galvanised steel.

8x60

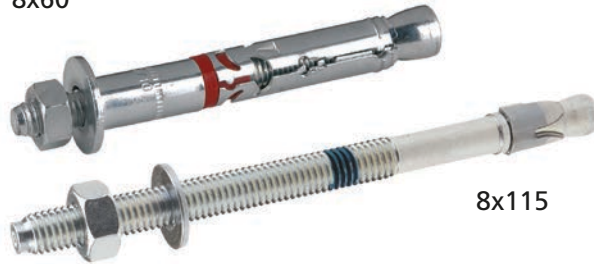

8x115

Code No.	Type	Hole diameter
4016606	8 x 60	12
4016603	8 x 115	8

Support

Material:
Black powder-coated steel,
Galvanised fastenings.

Includes:
Comple with fixing for pillar profile. (For floor fixing, see above)

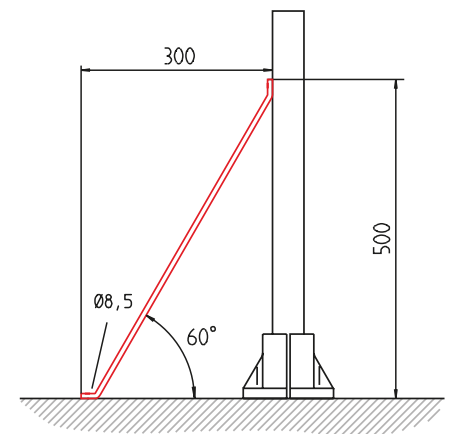

Code No.	Type
4082561	Support 60°

Accessories

Corner joint

Version KL



Version KLE



Version KLK



Version KLA



Version KLV

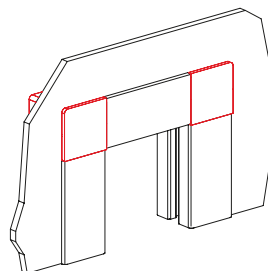
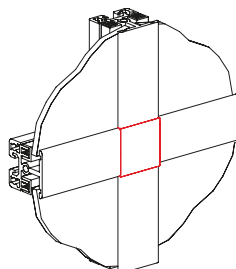
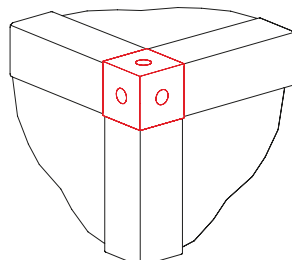
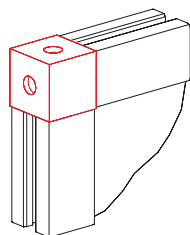

- Connection element for right-angled connections for clamping and inserting profiles (see page 416–417).
- The fixing screws are inserted directly into the profile. Centring pins prevent profile torsion.
- With versions KL/KLE, the screw holes can optionally be sealed with a plastic cap.

Material:

Die-cast zinc, gravity die-cast aluminium (see table)

Includes:

Includes all parts required to fully assemble one corner joint

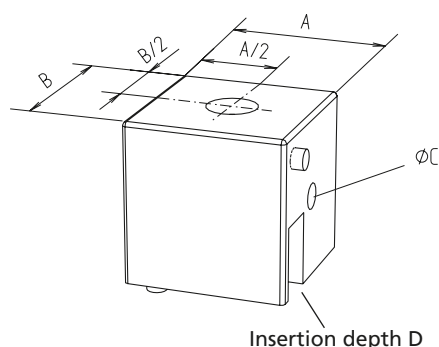
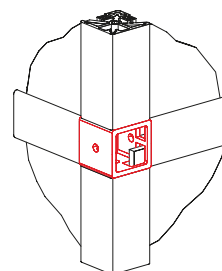

							[mm]
Code No.	Type	For profile	A	B	C	D	
Die-cast zinc							
4202406	KL 30	KL,ESP,ESP-2, F-/G/GG/2G/3G	30	30	5.4	13	
4212406	KL 40		40	40	6.4	18	
4702406	KLE 30	KLE,F-/G/GG, 2G/3G	30	30	5.4	13	
4712406	KLE 40		40	40	6.4	18	
4202409	KLA 30	KL,ESP,ESP-2	30	30	5.4	13	
4212409	KLA 40		40	40	6.4	18	
Gravity die-cast aluminium							
4202408	KLK 30	KLD	30	30	5.4	13	
4212408	KLK 40	KLD	40	40	6.4	18	
4202407	KLV 30	KLE, KLD	30	30	5.4	13	
4212407	KLV 40		40	40	6.4	18	
Stopper (black)							
4018597	KL/KLE 30	Pack of 100					
4018598	KL/KLE 40						
Cap (black)							
4000421	KL 30	Single component					
4010421	KL 40						



Corner joint

Corner joint KLW



Corner joint KLWK

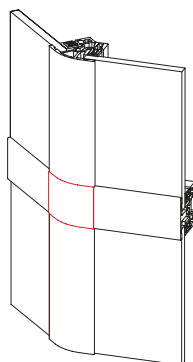
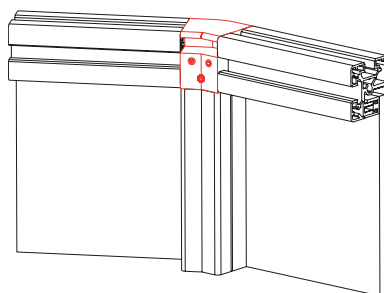

- Connection element for assembling profile angle brackets and clamping profiles
- Centring pin provides rotation locking

Material:

Die-cast zinc, black powder-coated aluminium (see table)

Includes:

Includes all parts required to fully assemble one corner joint

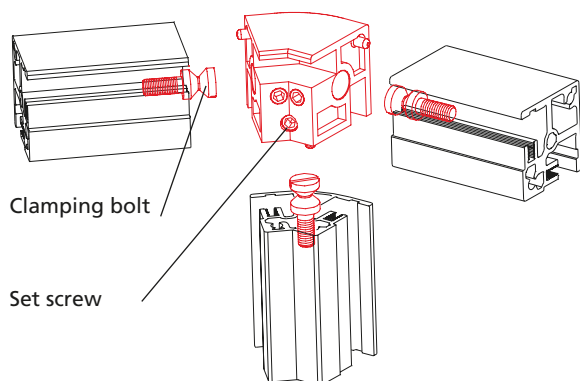

Assembly steps

1. Screw clamping bolt into profile
2. Put together with corner joint
3. Tighten set screw on corner joint – done!

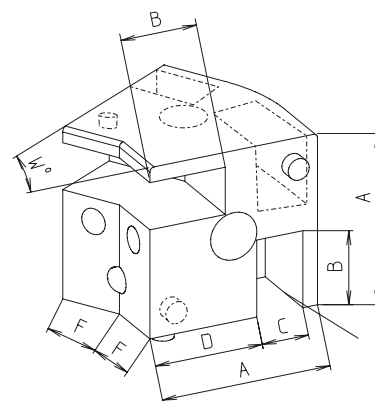

Insertion depth B

*If using W-profiles, the corners of panels may have to be notched.

Code No.	Type	For profile*	A	B	C	D	F	W
Die-cast zinc								
4412406	KLW 30-30	KLW 30-30, KL, KLE, ESP 30	30	13	8	19.5	11.0	30°
4422406	KLW 30-45	KLW 30-45, KL, KLE, ESP 30	30	13	8	19.5	8.8	45°
4622406	KLW 30-60	KLW 30-60, KL, KLE, ESP 30	30	13	8	19.5	8	60°
4432406	KLW 30-90	KLW 30-90, KL, KLE, ESP 30	30	13	8	19.5	10.0	90°
4472406	KLW 40-45	KLW 40-45, KL, KLE, ESP 40	40	18	11	25.5	11.7	45°
4632406	KLW 40-60	KLW 40-60, KL, KLE, ESP 40	40	18	11	25.5	11.5	60°
4482406	KLW 40-90	KLW 40-90, KL, KLE, ESP 40	40	18	11	25.5	15.0	90°
Black powder-coated aluminium								
4402406	KLW 30-15	KLW 30-15, KL, KLE, ESP 30	30	13	8	19.5	13.0	15°
4452406	KLW 40-15	KLW 40-15, KL, KLE, ESP 40	40	18	11	25.5	17.4	15°
4462406	KLW 40-30	KLW 40-30, KL, KLE, ESP 40	40	18	11	25.5	14.6	30°
4422407	KLWK 30-45	KLW 30-45, KLD 30	30	13	8	19.5	8.8	45°
4472407	KLWK 40-45	KLW 40-45, KLD 40	40	18	11	25.5	11.7	45°

Connection element -S- (Click&Safe)



- Operation complies with EU Machinery Directive 2006/42/EC
- Extremely quick and simple assembly without tools and without fastenings
- Angle compensation ± 5 degrees between post and frame
- Disassembly only possible with a special unlocking tool according to the machinery directive

Material: Black plastic, galvanised steel fastenings

Includes: Connection elements to take one profile frame (2 tops, 2 bottoms, fastenings)

Connection element



Unlocking tool

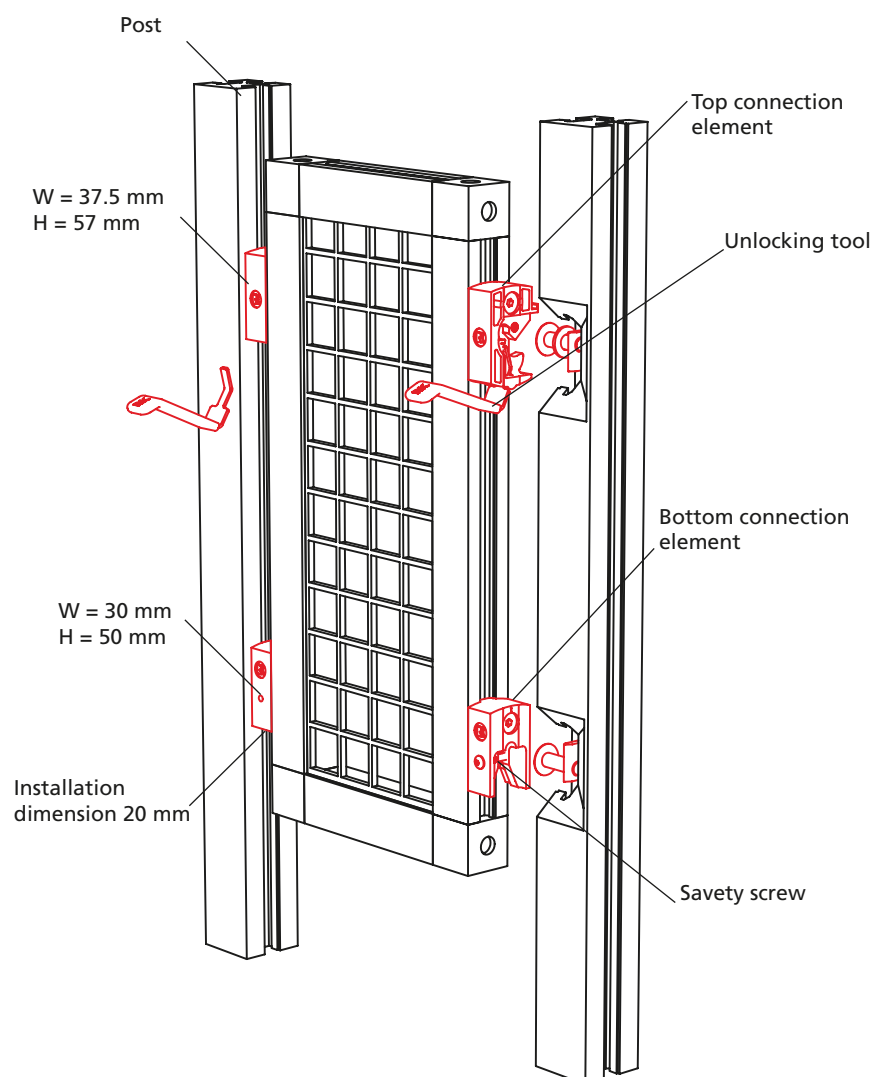

According to the machinery directive 2006/42/EC (valid from 29/12/2009)

Code No.	Type	Slot geometry
4000657	Connection element 30	30
4010657	Connection element 40	40
4000658	Connection element 30-40	30 to 40
4016697	Unlocking tool, set of 2	



Assembly:

1) Insert frame into the lower holder.



2) Press frame into the holder at the top.
The safety guard element automatically engages and locks.

Done!



A safety guard element is disassembled with a special unlocking tool according to the machinery directive.

Accessories

Bracing plate



- For additional reinforcement if required

Material: Black powder-coated steel, galvanised fastenings
Includes: Complete with fixing set

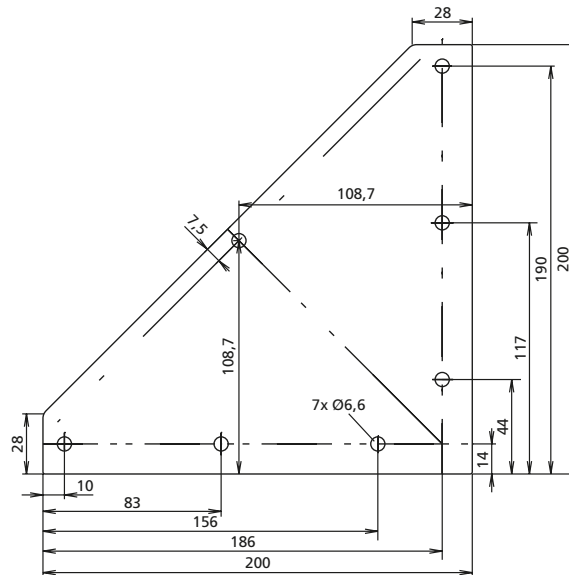

Code No.	Slot geometry
4012112	40

Cover profile

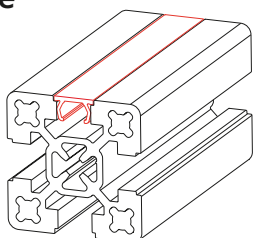

- For the flush covering of longitudinal slots.
- Due to the geometry of type 1, it is possible to route leads in the slot. Type 2, on the other hand, is easier to take out of the profile slot (without leaving residues).

Material: Plastic, further special colours available on request

White aluminium
RAL 9006



Light grey
RAL 7035



Rape yellow
RAL 1021



Traffic red
RAL 3020



Signal blue
RAL 5005



Black
RAL 9005

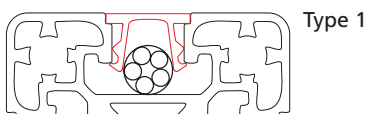

Type 1

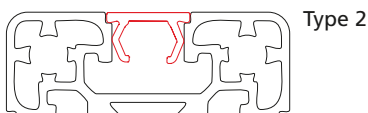

Type 2

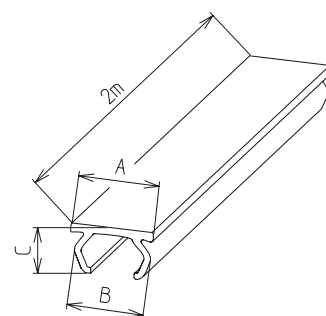

Code No.	Type	Colour	A	B	C
4000575	2	Light grey	12	11.2	6.4
4000577	2	White aluminium	12	11.2	6.4
4000579	2	Rape yellow	12	11.2	6.4
4000581	2	Traffic red	12	11.2	6.4
4000583	2	Signal blue	12	11.2	6.4
4000570	2	Black	12	11.2	6.4
4000585	1	Rape yellow	12	11.2	6.4
4008570	1	Black	12	11.2	6.4
NEW 4000586	1	Transparent	12	11.2	6.4

Please note that, for typographical reasons, the colours illustrated here are only an approximation of the RAL colours.



Profile seal

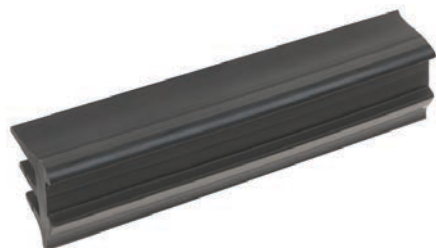

- For sealing panels (see page „Panels“ on page 447). The clampable wall thickness is reduced by 2 mm.

Material: Black plastic

Code No.	Sealing	For panel thickness	Slot geometry	Length
421857110000	1-sided	*For all clamping profiles	30, 40	10 m
421857150000				50 m
4218571100000				100 m

Door gap seal



- Acts as a door stop
- Compensates for variation in the door gap width

Material: Black plastic
Shore hardness: 55 Shore

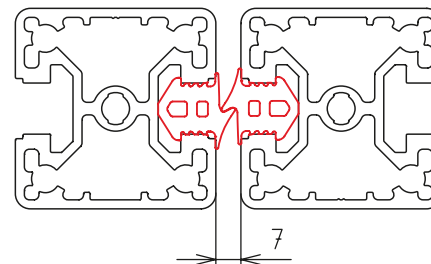

Code No.	Type	Slot geometry
401851810000	Door gap seal, 10 m roll	40
401851850000	Door gap seal, 50 m roll	40
4018518100000	Door gap seal, 100 m roll	40

Rim



- The rim is simply pressed into the profile slot and protects the structure against damage.
- Application examples include door stop protection or as edge protection when handling structures.
- The profile is available to cut to size or on a roll.

Material: Black plastic
Shore hardness: 70 Shore

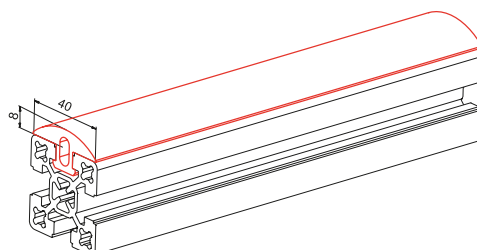

Code No.	Type	Slot geometry
4018594	Rim, 30 m roll	40
401859910000	Rim, 10 m roll	40

Accessories

Hinges

Material:
Black anodised aluminium,
galvanised steel parts
Includes:
With fixing set

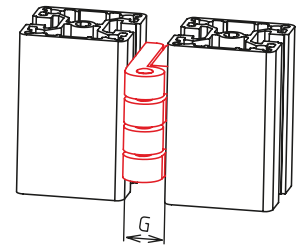

Lift off hinge (narrow)

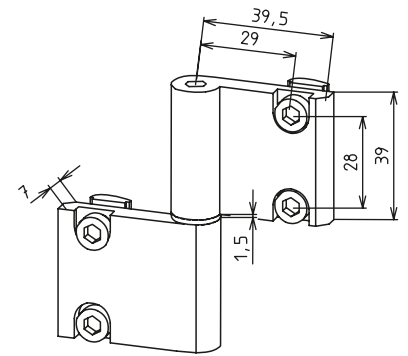
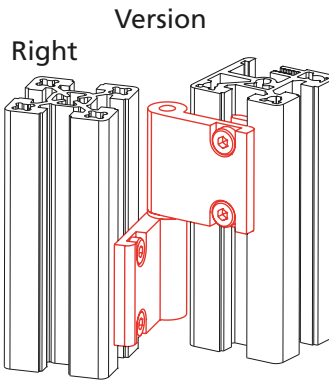

Butt hinge

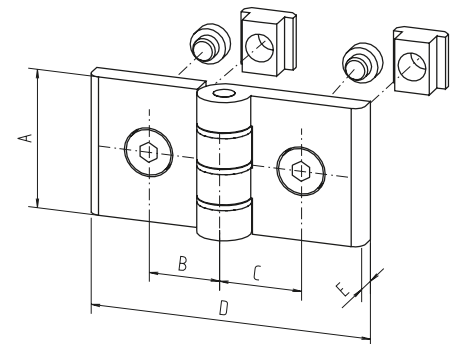
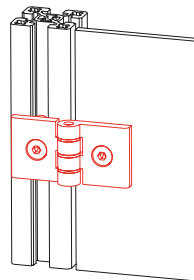

Lift off hinge

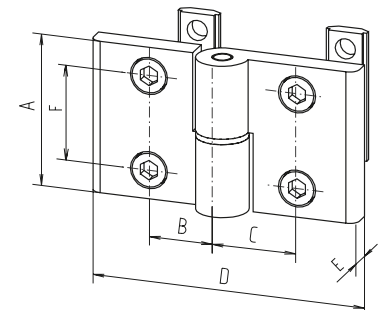
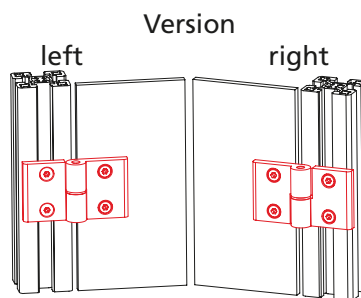

*For further versions,
please see section III

Code No.	Type	A	B	C	D	E	F	G	
4015525	Butt hinge, 40 slot geometry	40	22	22	79	7	-	15	
4015520	Lift off hinge, 40 slot geometry, left	45	22	22	79	7	28	15	
4015521	Lift off hinge, 40 slot geometry, left	45	22	22	79	7	28	15	
4015523	Lift off hinge, narrow, 40 slot geometry, left								7.5
4015522	Lift off hinge, narrow, 40 slot geometry, right							See diagram	7.5

Ball catch

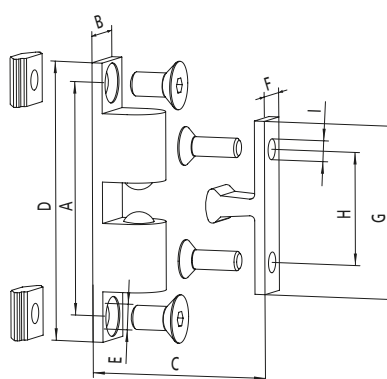
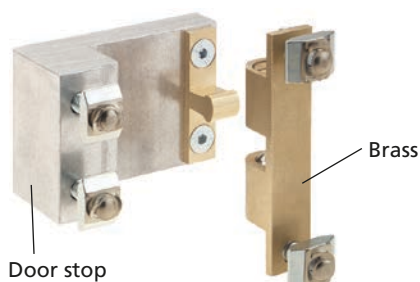

Material: Aluminium, brass

Fixing:
Galvanised steel.

Code No.	Type	A	B	C _{min}	D	E	F	G	H	I
4010606	Without door stop	48.5	12	11.6	58	5.3	8.5	36	23.5	4.3
4000608	With door stop for fixing profile 30 to 30									
4010607	With door stop for fixing profile 30 to 40									
4010608	With door stop for fixing profile 40 to 40									
4000609	With door stop for fixing profile 50 to 50									

Magnetic lock

■ Suitable from profile size 40.
Complete with fixing set.

Material: Plastic, galvanised steel parts.

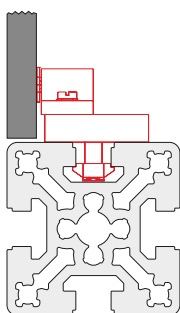
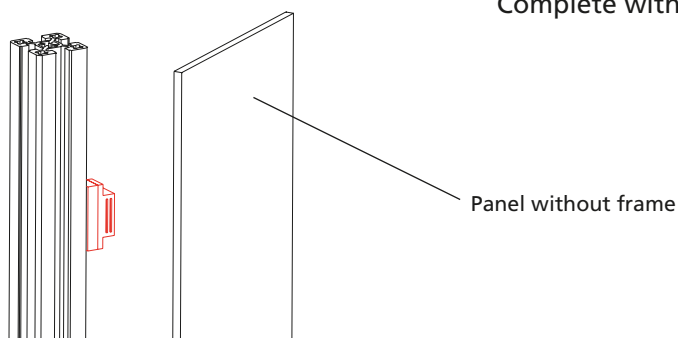

Fig. 1

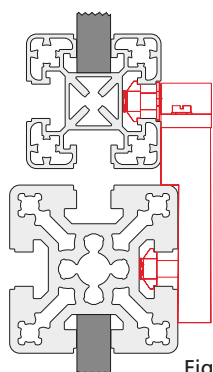

Fig. 2

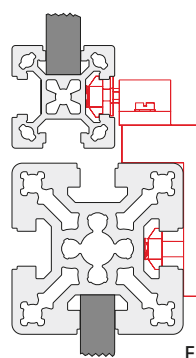
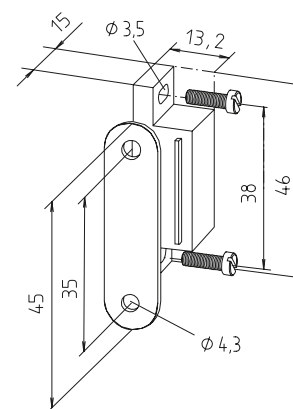

Fig. 3



Code No.	Profile assembly	Installation	Sim. to fig.
4010605	From 30	Without frame	1
4010604	From 30	Profiles centr.	2
4000610	30 to 30	Profiles centr.	2
4010611	40 to 30	Profiles centr.	2
4010612	40 to 30	Profiles flush	3
4080603	50 to 30	Profiles flush	3
4080606	50 to 40	Profiles centr.	2
4080604	50 to 40	Profiles flush	3

Accessories

Slam Latch PRO

NEW

Material: die-cast aluminium
black powder-coated

Includes:
complete with fixing set.

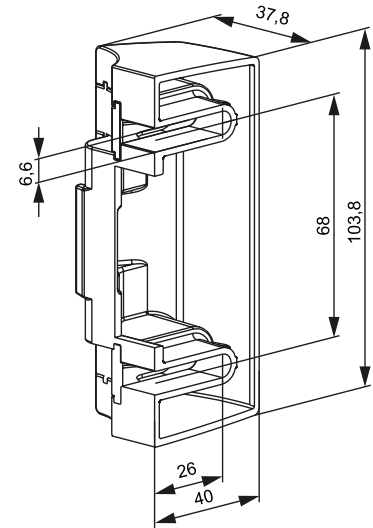
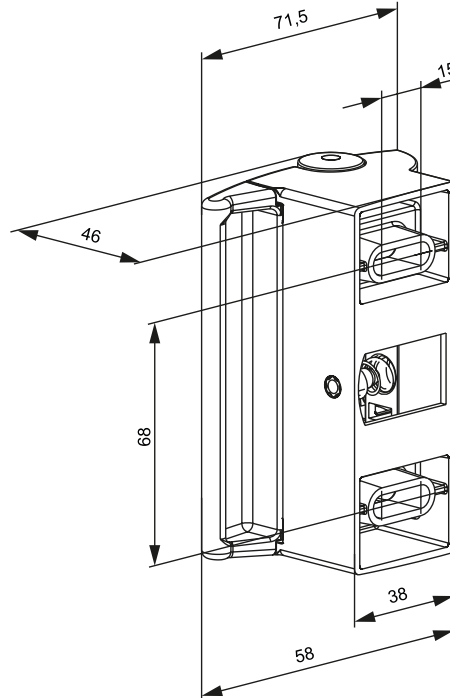

[mm]

Code No.	Slot geometry
401A530	40

Slam Latch Compact

NEW

Material: die-cast aluminium
black powder-coated

Includes:
complete with fixing set.

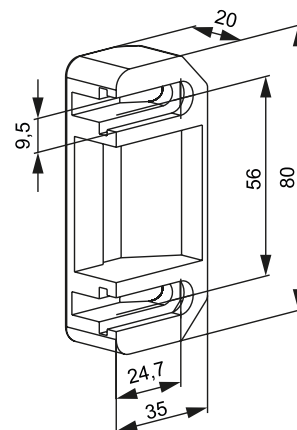
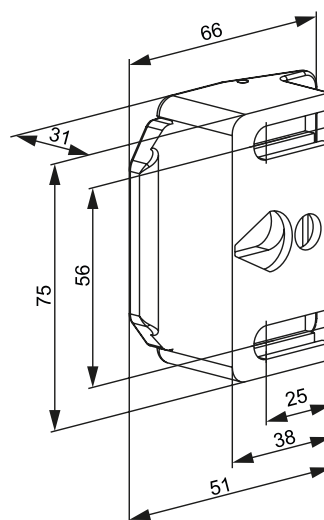
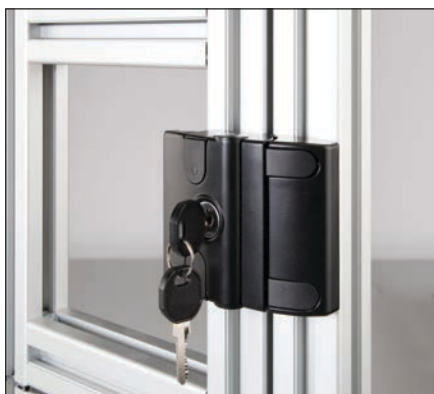

[mm]

Code No.	Slot geometry
401A531	40

Accessories

Door stopper



Set screws for fine adjustment of the door

■ Suitable from profile size 40.

Material: Black plastic
Includes:
With fastenings, galvanised steel

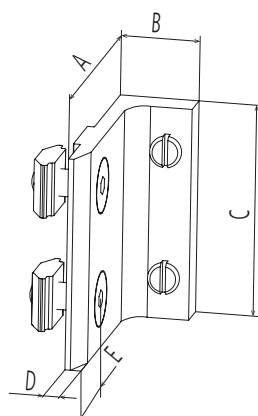

Code No.	Slot geometry	A	B	C	D	E
4008650	30	34	14.7	40	3	11
4018650	40	44	14,7	40	3	16

[mm]

Handle

Material size 150 and 197:
Black plastic, fibreglass-reinforced
Material size 152:
Black powder-coated aluminium
Includes:
With fastenings, galvanised steel.

Size 150 and 197

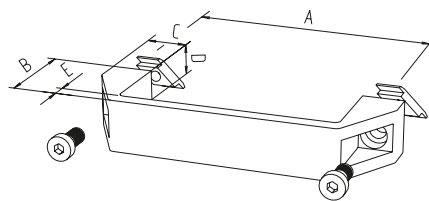

Size 152

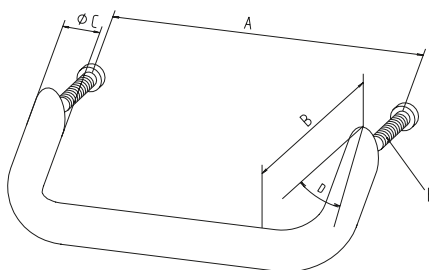

Code No.	Size	Slot geometry	A	B	C	D	E
4005596	152	Drill	128	50	20	35°	M6x30
4015598	152	Drill	128	50	20	35°	M6x40
4008596	150	30	131	44	22	27	7
4015596	150	40	131	44	22	27	7
4015597	197	40	178	50	22	28	8

[mm]



Door lock -KL-

- Installation between two clamping profiles without additional machining
- Available with door handle or with panic lock

Includes:
Complete door lock with cylinder lock, handle set and fastenings, galvanised steel parts.

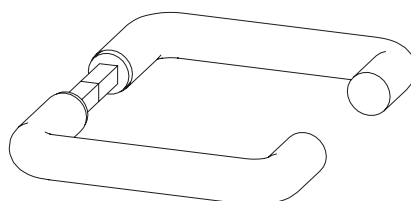

Handle set with hinged door and sliding door

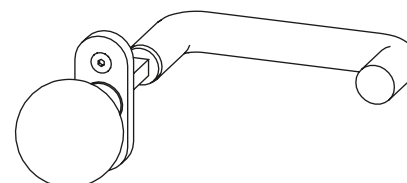

Handle set with hinged door with panic lock (one fixed knob, one door handle)



Hinged door version



Sliding door version

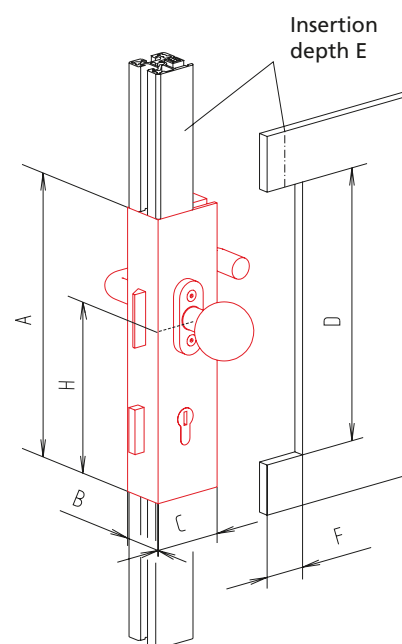

Figure shows right type

Code No.	Version	A	B	C	D	E	F	H
4210630	For hinged door KL 40, right	255	40	65	242	15	32	161.5
4210631	For hinged door KL 40, left	255	40	65	242	15	32	161.5
4210632	For hinged door KL 40 with panic lock, right	255	40	65	242	15	32	161.5
4210633	For hinged door KL 40 with panic lock, left	255	40	65	242	15	32	161.5
4210636	For sliding door KL 40, right	255	40	65	242	15	32	132
4210637	For sliding door KL 40, left	255	40	65	242	15	32	132

[mm]

Accessories

Roller module / sliding piece

- Primarily for use in sliding doors
- Profile slot fixation
- Very good running properties thanks to large roller diameter
- Sliding pieces act as a guide at the bottom of the sliding doors

Material: Plastic roller, plastic sliding piece

Includes:

Roller module complete with roller, cover plates and fastenings.
Sliding piece with set screws



Set screw M5x16 DIN913

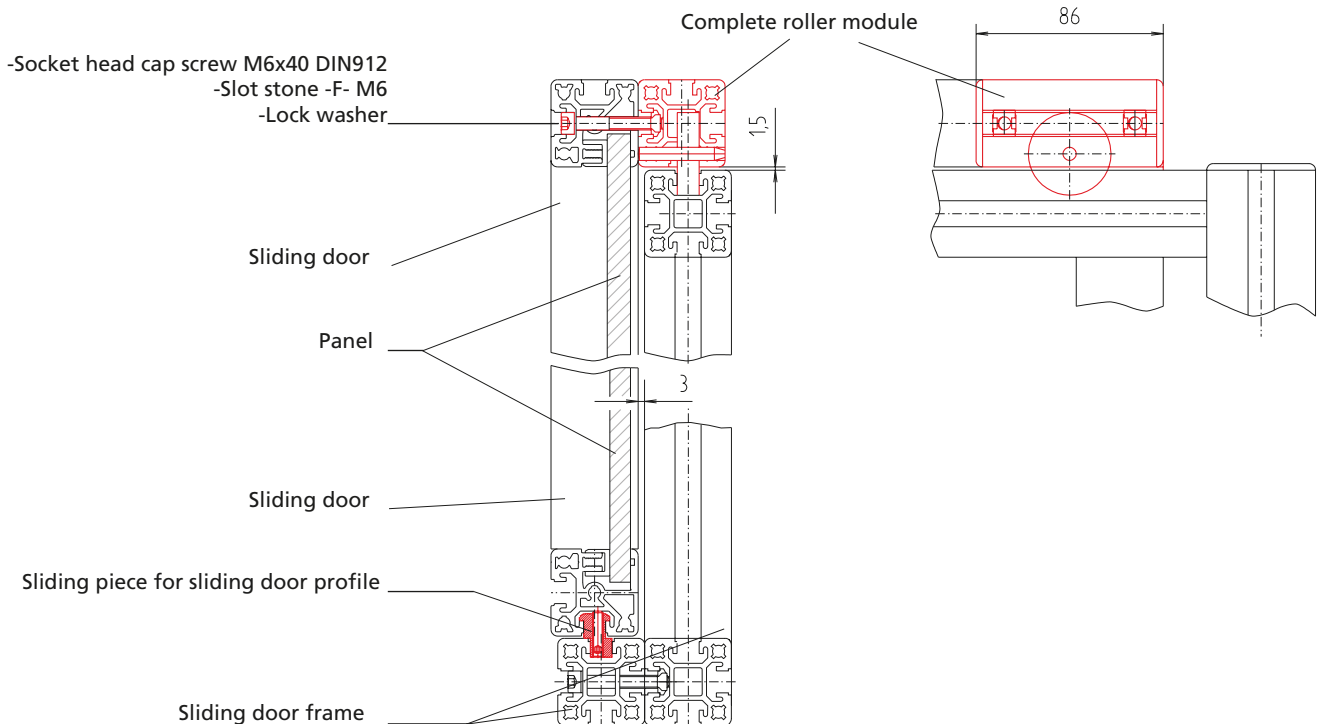
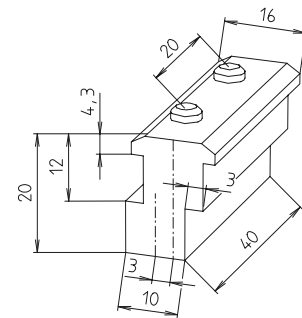
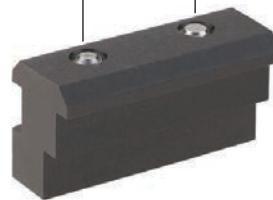

Code No.	Version
4018649	Complete roller carriage, from profile 40x40
4018648	Sliding piece for sliding door guide, from profile 40x40

Roller carriage

- Geared to sliding door profiles 30 and 40 (page 425)
- Can also be used as single components in structures

Material: Aluminium base body with slide bush, black plastic rollers

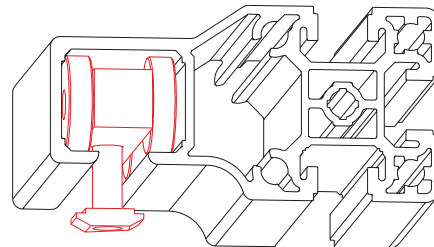

Sliding door profile

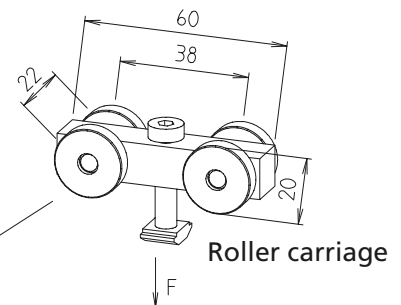
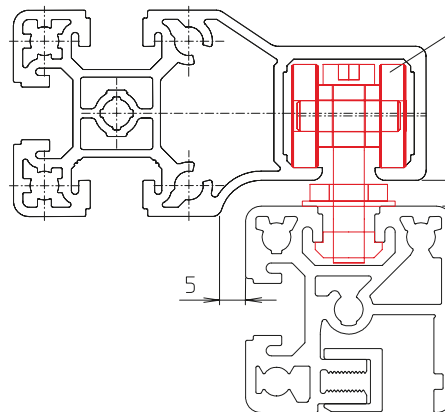

Roller carriage

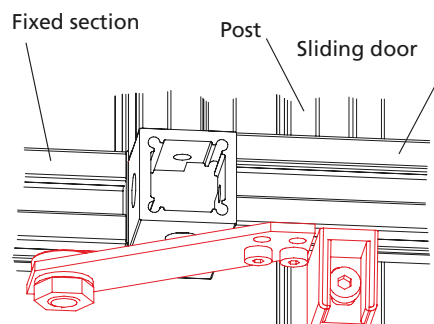

Bottom guide

Code No.	Type	Version	F
4170601	30	Complete roller carriage	150 N
4180601	40	Complete roller carriage	150 N
4008660	30	Bottom guide	
4018660	40	Bottom guide	

Safety switch AZ 15zvr

- For safely switching off circuits
- Suitable for hinged, flap, sliding and lifting doors

Technical data: Self-extinguishing fibreglass-reinforced thermoplastic

Actuator key:

Stainless spring steel

Degree of protection:

IP67 to IEC 529/EN 60529/DIN VDE 0470-1

Contact material: Fine silver

Contact type: One-pin, double-breaking, positively driven NC to VDE 001

Pivot radius: R_{\min} 450 mm

Rated isolation voltage:

VI 500 V approx. 25-60 Hz.

Constant current: 10 A

Rated operating current I_u AC 11h
4 A (230V), 2,5 A (380 V),
1A (500 W)

Short circuit resistance:

10 A (slow) 16 A (fast).

Contact gap 2 x 3 mm.

Positive opening travel/force:

8 mm / approx. 30 N

Mech. lifetime:

10×10^6 switching cycles

Operating temperature:

-30 to +80°C.

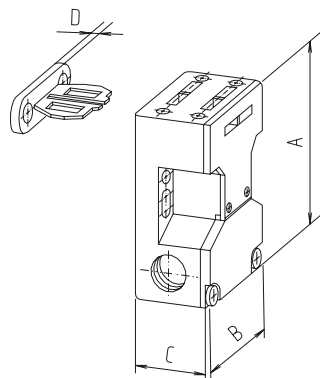

Code No.	Type	A	B	C	D
4010610	AZ 15 zvr for sliding door / lifting door	72	52	30	5
4010613	AZ 15 zvr for sliding door	72	52	30	5
4010614	AZ 15 zvr for flap door	72	52	30	5
4015610	Fixing set for sliding door, hinged door	Fig. 1, 2, 3		40 slot geometry	
4015602	Fixing set for lifting door	Fig. 4			

[mm]

Further fixing sets available on request

Fixing set for sliding and hinged door.

See fig. 1-3 on the next page.

Fixing set for lifting door

See fig. 14 on the next page.

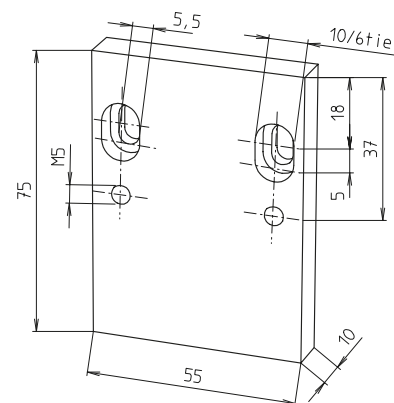
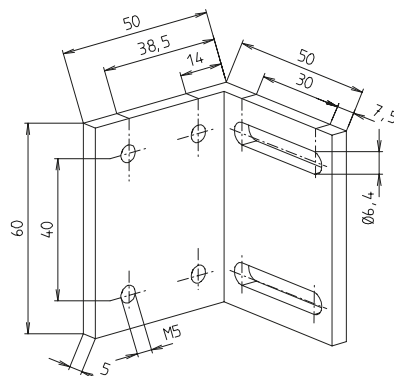
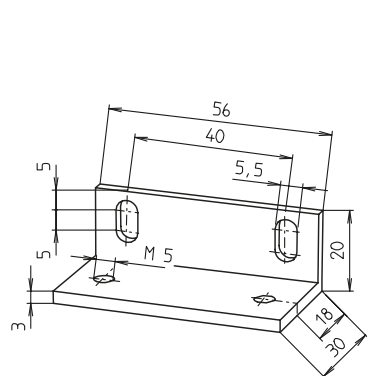

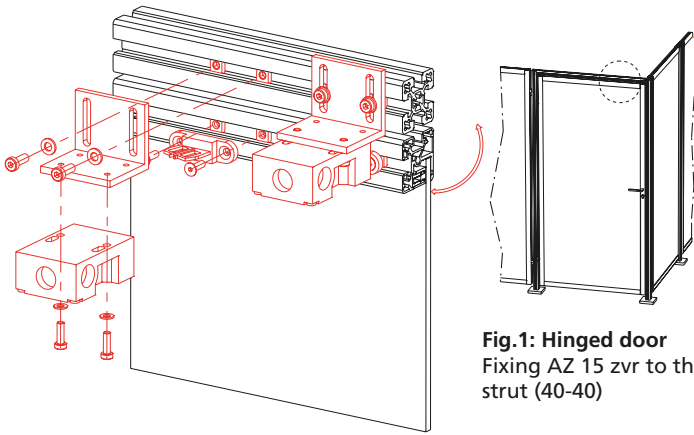

Fig. 1: Hinged door
Fixing AZ 15 zvr to the top strut (40-40)

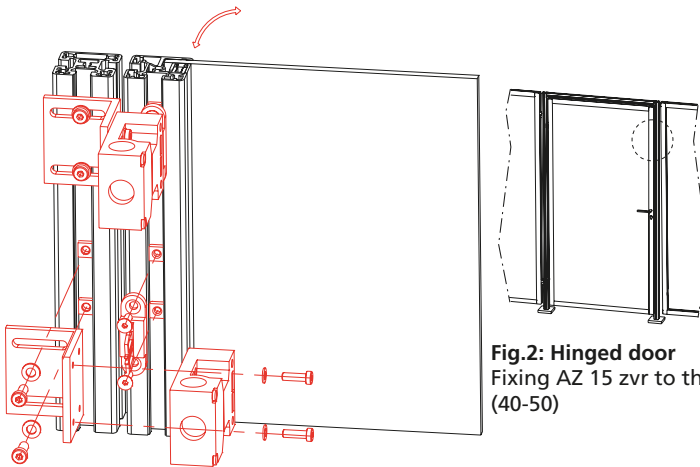

Fig. 2: Hinged door
Fixing AZ 15 zvr to the side strut (40-50)

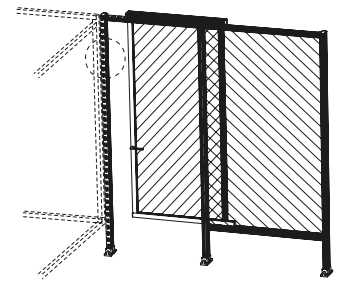

Fig. 3: Sliding door
Fixing AZ 15 zvr to the side strut (50-40)

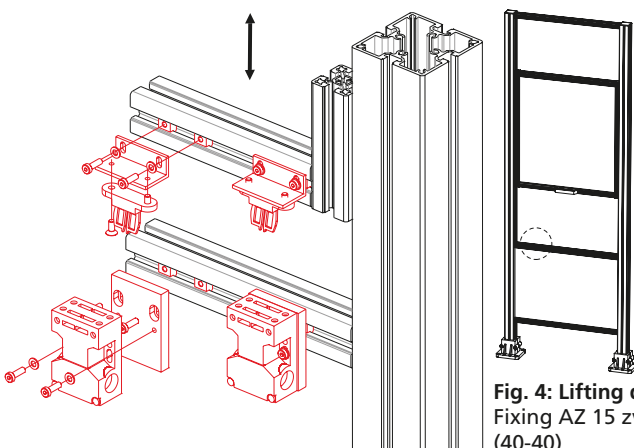
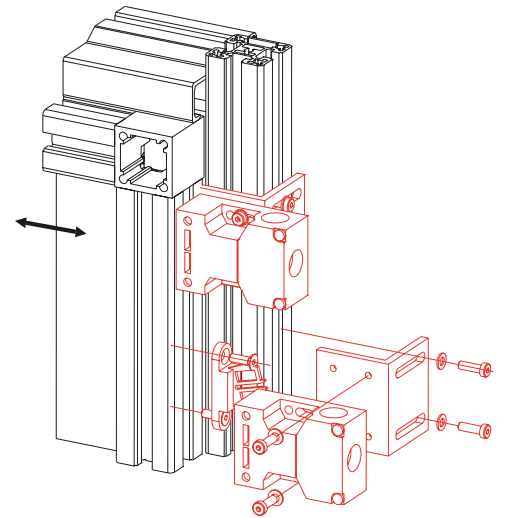

Fig. 4: Lifting door
Fixing AZ 15 zvr to the cross strut (40-40)

Safety switch AZM 161

- For safely switching off circuits. Suitable for hinged, sliding and lifting doors.

Technical data:

Self-extinguishing fibreglass-reinforced thermoplastic.

Degree of protection: IP67 to IEC 529/EN 60529/DIN VDE 0470-1

Contact type: One-pin, double-breaking, positively driven NC to VDE 001, additional contacts for signal purposes

Pivot radius: R_{\min} 900 mm

Constant current: 10 A Rated operating current Iu AC 11h 2 A (230 V)

Short circuit resistance: 6 A (slow) as positively driven NC position switch

Contact type: One-pin, double-breaking, positively driven NC to VDE 001, additional contacts for signal purposes

Pivot radius: R_{\min} 900 mm

Constant current: 10 A Rated operating current Iu AC 11h 2 A (230 V)

Short circuit resistance: 6 A (slow) as positively driven NC position switch

Positive opening travel/force: 8.8 mm / 10 N

Locking force F_{\max} : 2000 N

Mech. lifetime:

10×10^6 switching cycles

Operating temperature:

-25 to +60°C.

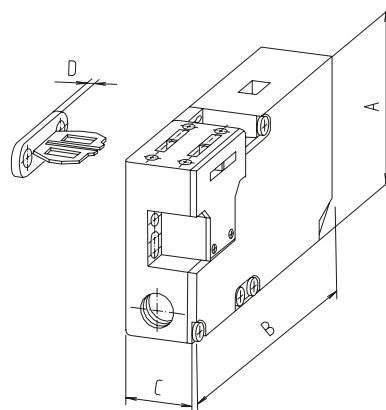

Code No.	Type	A	B	C	D
4010615	Switch AZM 161, for sliding door/lifting door/hinged door	90	130	30	5
Available on request*	Fixing set	40 slot geometry			

*Fixing sets available on request depending on the application

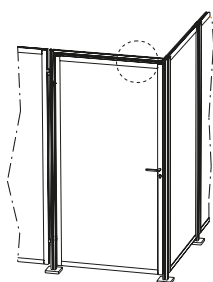
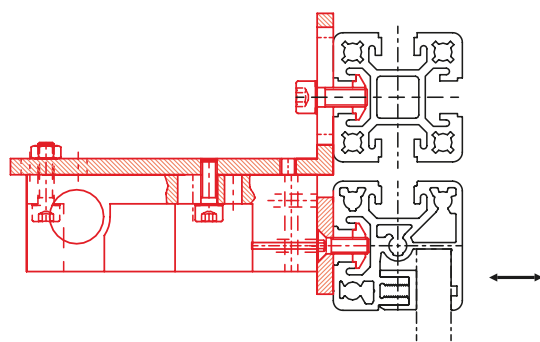

Fig.1: Hinged door
Fixing AZM 161 to the top strut (40-40)

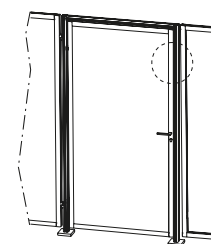
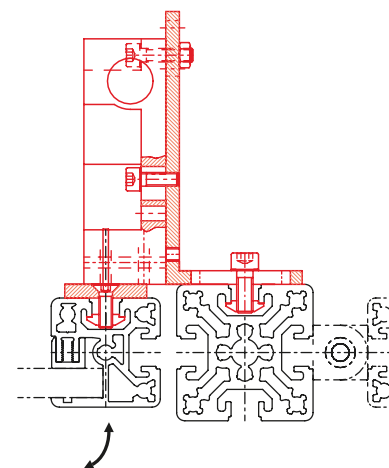

Fig.2: Hinged door
Fixing AZM 161 to the side strut (40-50)

Panels

- For doors, cladding, safety and table tops

Cut to specification

Further panels available on request

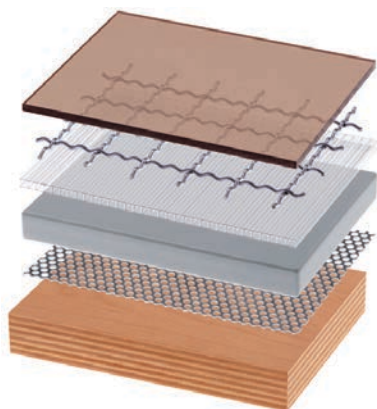

Code No.	Type	Thick-ness	Version	Max. size [m]	Weight [kg/m ²]
4018584	Makrolon	2 mm	Clear	3.05 x 2.05	2.40
4018586	Makrolon	4 mm	Tinted	3.05 x 2.05	4.80
4018576	Makrolon	6 mm	Clear	3.05 x 2.05	8.00
4018579	Makrolon	6 mm	Tinted	3.05 x 2.05	8.00
4018578	Makrolon	10 mm	Clear	3.05 x 2.05	13.00
4018582	Acrylic glass	4 mm	Clear	3.05 x 2.05	4.80
4018583	Acrylic glass	4 mm	Tinted	3.05 x 2.05	4.80
4018595	Acrylic glass	5 mm	Clear	3.05 x 2.05	6.00
4018563	Acrylic glass	5 mm	Blue, transparent	3.05 x 2.05	6.00
4018575	Acrylic glass	6 mm	Clear	3.05 x 2.05	7.20
4012575	Acrylic glass	6 mm	Tinted	3.05 x 2.05	7.20
4018577	Acrylic glass	10 mm	Clear	3.05 x 2.05	13.00
4018580	Acrylic glass	10 mm	Tinted	3.05 x 2.05	13.00
4012576	Trespa	6 mm	Brown	3.05 x 1.53	8.40
4012586	Trespa	6 mm	Silver-grey	3.05 x 1.53	8.40
4012587	Trespa	10 mm	Silver-grey	3.05 x 1.53	13.00
4018570	Koematex	6 mm	White	3.05 x 1.56	4.20
4018571	Koematex	8 mm	White	3.05 x 1.56	5.60
4018572	Koematex	10 mm	White	3.05 x 1.56	6.00
4012579	Multiplex	30 mm	Untreated	2.20 x 1.85	27.00
4015573	Aluminium	2 mm	Clear anodised	2.00 x 1.00	5.40
4012582	Table top	19 mm	Grey plastic-coated, glued edges	2.65 x 2.10	14.70
4012577	Composite	6 mm	Clear anodised	3.05 x 1.50	7.30
4012511	MDF panel	6 mm	Untreated	2.62 x 2.07	8.20
4012512	MDF panel	8 mm	Untreated	2.62 x 2.07	9.20
4016576	Perforated plate	1 mm	Round holes in staggered rows, galvanised steel	1.50 x 3.00	4.30
4016577	Wire mesh 20x20	2.5 mm	Galvanised steel	1.40 x 2.50	2.40
4016578	Wire mesh 30x30	3 mm	Galvanised steel	2.11 x 3.00	3.70
4016579	Wire mesh 40x40	4 mm	Galvanised steel	2.00 x 3.00	4.70

Fax: +49 (0)571 9335-119

Telephone: +49 (0)571 9335-0

E-mail: anfrage.vertrieb@rk-online.de

Company Cust. No.....

Street City

Telephone Fax.....

Contact..... Dept.....

Remarks

.....

Sketch

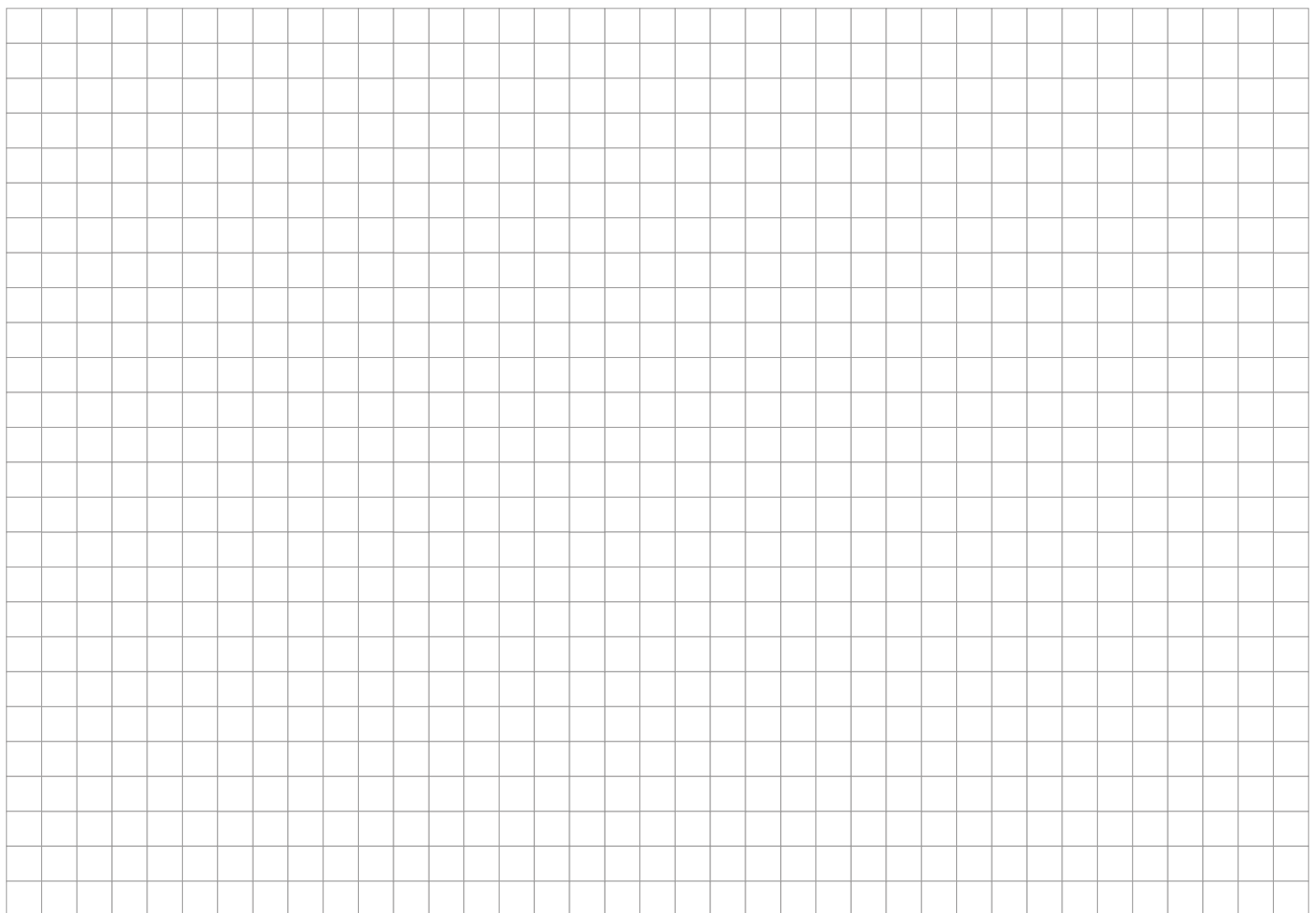

Safety guard

Protection system

Height details

2200 mm 1600 mm

2000 mm mm

Please give details of the module version, panels and doors in the sketch.

Submission of offer / date:

Remarks:

.....

RK Rose+Krieger GmbH • Connecting and positioning systems • Postfach 1564 • 32375 Minden

